

IN THE
Supreme Court of the United States

MERRICK B. GARLAND, ATTORNEY GENERAL, ET AL.,
PETITIONERS,

v.

JENNIFER VANDERSTOK, ET AL.,
RESPONDENTS.

**On Writ of Certiorari to the
United States Court of Appeals
for the Fifth Circuit**

**BRIEF OF THE DISTRICT ATTORNEY FOR
NEW YORK COUNTY AND THE CITY OF NEW
YORK AS *AMICI CURIAE* IN SUPPORT OF
PETITIONERS**

Alvin L. Bragg, Jr.
*New York County
District Attorney*

Steven C. Wu*

Philip V. Tisne

Brent Yarnell

One Hogan Place

New York, NY 10013

(212) 335-9326

wus@dany.nyc.gov

* Counsel of Record

Muriel Goode-Trufant
Acting Corporation

*Counsel of the City
of New York*

Richard Dearing

Claude S. Platton

Philip Young

100 Church Street

New York, NY 10007

July 2, 2024

TABLE OF CONTENTS

	<i>Page</i>
TABLE OF AUTHORITIES	ii
INTEREST OF AMICI CURIAE.....	1
SUMMARY OF ARGUMENT.....	3
ARGUMENT	4
A. Ghost Guns Pose a Significant Danger to Public Safety.	4
1. Ghost guns have increasingly fallen into the hands of dangerous individuals who would otherwise be barred from possessing firearms.....	5
2. Ghost guns are functionally equivalent to traditional guns and can be easily assembled with minimal effort.....	10
B. Federal Regulation Is an Essential Complement to State and Local Efforts to Address the Proliferation of Ghost Guns.	17
1. New York has enacted its own restrictions on ghost guns and ghost gun components.	18
2. Amici have vigorously enforced state and local laws to halt the spread of ghost guns..	20
3. Federal regulation can address interstate sales of ghost guns and ghost gun parts and prevent circumvention of state and local restrictions.	25
CONCLUSION.....	29

TABLE OF AUTHORITIES

FEDERAL LAWS

18 U.S.C. § 921(a).....1

Definition of “Frame or Receiver” and
Identification of Firearms,
87 Fed. Reg. 24,652 (Apr. 26, 2022) 1, 4, 5, 8, 25

Gun Control Act of 1968, Pub. L. No. 90-618,
§ 101, 82 Stat. 1213 (1968)17, 26

STATE LAWS

2021 N.Y. Laws

Ch. 51918

Ch. 52018

N.Y.C. Admin. Code

§ 10-301(8).....20

§ 10-301(22).....20

§ 10-31420

N.Y. Penal Law

§ 265.00(3)(a).....18

§ 265.00(3)(b).....18

§ 265.00(3)(c).....18

§ 265.00(32)18

§ 265.01(9)19

§ 265.01(10)18

§ 265.6019

§ 265.6119

§ 265.6318

§ 265.6418

LEGAL FILINGS

<i>City of New York v. Arm or Ally et al.</i> , No. 22-cv-05525 (S.D.N.Y. June 29, 2022)	
Complaint.....	21, 23, 24
Declaration of Francesca Rosa	23
Permanent Injunction	25
Complaint, <i>City of Philadelphia v. Polymer80, Inc., et al.</i> , Case No. 230700362 (Philadelphia Ct. Comm. Pleas 2023)	6
Declaration of David L. Borges, <i>Syracuse v. Bureau of Alcohol, Tobacco, Firearms and Explosives</i> , Case No. 20-cv-6885 (GHW) (S.D.N.Y. Dec. 30, 2020)	16
Second Amended Complaint, <i>James v. Arm or Ally LLC</i> , Case No. 22-cv-06124 (JMF) (S.D.N.Y. March 13, 2023)	12, 14
Statement of Facts, <i>People v. Coley</i> , Ind. No. 74957-23 (N.Y. Cty. Sup. Ct., Oct. 20, 2024)	9
Statement of Facts, <i>People v. Guerrero</i> , Ind. No. 72178-24 (N.Y. Cty. Sup. Ct., May 28, 2024).....	9
Statement of Facts, <i>People v. Loyola</i> , Ind. No. 71721-22 (N.Y. Cty. Sup. Ct., May 25, 2022).....	8, 11, 28
Statement of Facts, <i>People v. Rivera</i> , Ind. No. 74227-22 (N.Y. Cty. Sup. Ct., Oct. 11, 2022)	7

PRESS RELEASES

Press Release, Mayor of Baltimore City, *City of Baltimore Reaches Settlement in Polymer80* (Feb. 21, 2024), <https://mayor.baltimorecity.gov/news/press-releases/2024-02-21-city-baltimore-reaches-settlement-polymer80>.....6

Press Release, Office of the Mayor, *Mayor Adams Stops Additional Ghost Gun Retailer from Selling Ghost Gun Kits to NYC Residents* (Oct. 13, 2022), <https://perma.cc/UT4Z-82A6>24

Press Release, Office of the Mayor, *Mayor Adams Stops Additional Ghost Gun Retailer from Selling Ghost Gun Kits to NYC Residents* (Sept. 6, 2022), <https://perma.cc/4K4Y-55NG>.....24

Press Release, Office of the Mayor, *Mayor Adams Stops Two Ghost Gun Retailers From Selling Ghost Gun Kits To NYC Residents* (Aug. 25, 2022), <https://perma.cc/7HNW-GE48>.....24

Press Release, Office of the Mayor, *Mayor Adams Successful in Halting Online Ghost Gun Retailer Indie Guns from Unlawfully Selling Kits to NYC Residents* (Oct. 27, 2022), <https://perma.cc/UF6F-3THZ>24

Press Release, New York County District Attorney,
*D.A. Bragg Announces 69-Count Indictment in
Ghost Gun Factory Takedown* (Feb. 3, 2023),
<https://manhattanda.org/d-a-bragg-announces-69-count-indictment-in-ghost-gun-factory-takedown>9

Press Release, New York County District Attorney,
*D.A. Bragg Announces Guilty Plea of Eleazer
Edelstein For Manufacturing Ghost Guns and
Making Threats Against Former Girlfriend*
(Dec. 18, 2023), <https://manhattanda.org/d-a-bragg-announces-guilty-plea-of-eleazer-edelstein-for-manufacturing-ghost-guns-and-making-threats>10

Press Release, New York County District Attorney,
*D.A. Bragg Announces Prison Sentence for
Manufacturing and Possessing Ghost Gun in
UWS Apartment* (Dec. 13, 2022),
<https://manhattanda.org/d-a-bragg-announces-prison-sentence-for-manufacturing-and-possessing-ghost-gun-in-uws-apartment>7, 28

Press Release, New York County District Attorney,
*D.A. Bragg Applauds YouTube For Changing
Firearm Content Guidelines In Response To
Advocacy From Office* (June 5, 2024),
<https://manhattanda.org/d-a-bragg-applauds-youtube-for-changing-firearm-content-guidelines-in-response-to-advocacy-from-office/>22

Press Release, New York County District Attorney,
*D.A. Bragg Indicts Upper East Side Man for
 Manufacturing 14 Ghost Guns* (Nov. 28, 2022),
[https://manhattanda.org/d-a-bragg-indicts-
 upper-east-side-man-for-manufacturing-14-
 ghost-guns](https://manhattanda.org/d-a-bragg-indicts-upper-east-side-man-for-manufacturing-14-ghost-guns)8

OTHER AUTHORITIES

80 Percent Arms, *Build Your Own Gun in 1 Hour
 100 Legal* (August 20, 2018),
<https://vimeo.com/285916385> 15, 16

80 Percent Arms, *What is an 80 Lower Receiver?*,
<https://www.80percentarms.com/80-lowers> 15

Brónagh Tumulty, “*Ghost guns*” seized by Chicago
*police steadily rising as Biden administration
 plans to target them* (Apr. 8, 2021).....6

Bureau of Alcohol, Tobacco, Firearms and
 Explosives, *Open Letter to All Federal Firearms
 Licensees—Impact of Final Rule 2021-05F
 on Partially Complete Polymer80, Lone
 Wolf, and Similar Semiautomatic
 Pistol Frames* (Dec. 27, 2022).....12, 14

Franklin E. Zimring, *Firearms and Federal Law:
 The Gun Control Act of 1968*, 4 J. Legal Stud.
 133 (1975).....25

H.R. Rep. 90-1577, *reprinted in* 1968 U.S.C.C.A.N.
 4410 (1968).....26

Introducer’s Mem., *reprinted in* Bill Jacket for
 Ch. 519 (2021).....19

Jeff Pegues, *Rise in crime fueled in part by “ghost” guns, ATF says*, CBS EVENING NEWS (Feb. 2, 2022).....6

Letter from District Attorney Alvin Bragg to Neal Mohan (Apr. 24, 2024), <https://manhattanda.org/wp-content/uploads/2024/04/DA-Bragg-Letter-to-Neal-Mohan.4.24.24.pdf>22

Minutes of the Meeting of the Arizona Assembly Committee on Judiciary (Mar. 17, 2021)27

N.Y. Assembly Bill No. 7489-A (2023-2024)19

N.Y. Senate Bill No. 7364-A (2023-2024)19

Polymer80, Inc., *Comment on Proposed Rule Entitled “Definition of ‘Frame or Receiver’ and Identification of Firearms”* (Aug. 19, 2021), <https://www.regulations.gov/comment/ATF-2021-0001-244128>16

Polymer80, *PF940V2 Pistol Frames, 80% Instructions* (undated), https://polymer80.com/wp-content/uploads/2024/01/Polymer80_-_PF940v2_Series_Pistol_Kit_instructions.pdf.....12, 13, 14

Polymer80 (@polymer80inc), INSTAGRAM (April 17, 2020), https://www.instagram.com/tv/B_F9zmtPKkW/?igsh=MWh1c2Z4ZTV2cW5nOA== (last visited June 27, 2024).16

Polymer 80 CEO Loran Kelley about the Baltimore Settlement, Politics, and more, FREE TRADE MAFIA (March 8, 2024), <https://www.youtube.com/watch?v=45ZuI04yWC4>.....11, 17

Social Media Post Prompts Baltimore Police To Seize Ghost Gun, Make Arrest, MARYLAND NEWS (Feb. 6, 2022)6

Sponsor’s Mem., N.Y. Senate Bill No. 7364-A19

Statement of Senator Joseph Tydings, 114 Cong. Rec. 13647 (1968)27

INTEREST OF AMICI CURIAE

The District Attorney for New York County and the City of New York file this brief as amici curiae in support of the federal petitioners. Amici have a direct interest in the Final Rule at issue in this litigation, which adopts the commonsense interpretation that the terms “firearm” and “frame or receiver” in the Gun Control Act of 1968, 18 U.S.C. § 921(a)(3)(A)-(B), include parts kits or partially completed components that may readily be converted into a functioning firearm, frame, or receiver. Definition of “Frame or Receiver” and Identification of Firearms, 87 Fed. Reg. 24,652 (Apr. 26, 2022) (codified at 27 C.F.R. §§ 478.11, 478.12). The products covered by the Final Rule have subjected New York City to a proliferation of ghost guns—unserialized, unregistered, and untraceable firearms that exacerbate the dangers of widespread gun possession while impeding efforts by law enforcement and local prosecutors to curb violent crime. The Final Rule provides critical support to the efforts of state and local offices like amici to halt the spread of ghost guns.

The New York County District Attorney’s Office, led by Alvin L. Bragg, Jr., is responsible for prosecuting crimes in Manhattan, the most densely populated county in the nation and home to more than 1.5 million residents. In 2020, the Office established the Ghost Guns Initiative to tackle the growing proliferation of untraceable ghost guns in New York City. The Initiative consists of a partnership between the Office and state and federal law enforcement partners that is dedicated to identifying and seeking relief against ghost gun builders and traffickers in the

City. Among other efforts, the Office and its partners in the Initiative have brought prosecutions involving the seizure of hundreds of ghost gun parts, completed ghost guns, and other illegal firearms components.

The City of New York is the largest municipality in the United States. Through the New York Police Department (“NYPD”) and other local law enforcement agencies, the City is responsible for protecting the public safety and ensuring the security of its 8.3 million residents. Over the past five years, the NYPD has seen a significant spike in the use of untraceable ghost guns to commit crimes. Although New York City remains the safest big city in America, the growth in the use of ghost guns makes the City’s streets, schools, public spaces, and homes significantly more dangerous. To combat the scourge of ghost guns, the NYPD created the Major Case Field Intelligence Team in 2020. The Team works closely with the City’s five district attorneys, as well as state and federal law enforcement, to stop the flow of ghost guns. The City also filed a civil lawsuit against out-of-state online retailers of ghost gun components; that lawsuit resulted in settlement agreements and court orders barring the retailers from selling ghost gun components to City residents.

Amici’s experiences addressing the problem of ghost guns confirm both the reasonableness of the Final Rule’s interpretation of the Gun Control Act and the importance of federal regulation in this area. The defendants in criminal prosecutions brought by the New York County District Attorney’s Office have in fact used weapons parts kits and partially complete frames or receivers to create functioning firearms

that pose the same dangers as pre-assembled weapons. The ease of accessing these products online or creating them using 3D printers has allowed dangerous individuals to amass arsenals of deadly handguns and rifles, even when they are unambiguously disqualified from possessing such weapons under state law. And although amici have vigorously enforced New York's own protections against ghost guns, federal regulation and federal enforcement are important adjuncts to state and local efforts. Amici thus have a strong interest in preserving the Final Rule and maintaining its complementary protections against the further spread of dangerous ghost guns.

SUMMARY OF ARGUMENT

As amici's experience confirms, ghost guns directly threaten public safety. These weapons are functionally identical to pre-assembled firearms. And they have exploded in popularity in New York City given the ease of obtaining and assembling these weapons and the perception that these firearms can escape regulatory scrutiny. Indeed, as the New York County District Attorney's Office has found in multiple prosecutions, these unserialized and unregistered weapons are often in the possession of dangerous individuals who are barred from owning firearms because of past felony convictions or other disqualifying factors.

New York has adopted a number of restrictions to halt the spread of ghost guns, and both the District Attorney and the City have vigorously enforced those protections. Those efforts have had a significant

effect—resulting in the seizures of hundreds of ghost guns and ghost gun parts and significant injunctive relief against online ghost gun manufacturers. But federal regulation and federal enforcement remain essential complements to amici’s efforts. Among other issues, amici’s experience shows that New York residents routinely obtain ghost guns or components from other States or from online retailers located outside of New York. The Final Rule at issue here thus provides important nationwide relief that supplements state and local efforts. In doing so, the Final Rule carries out one of the core functions of the Gun Control Act: to assist state and local law enforcement in controlling the traffic of deadly firearms within state borders.

ARGUMENT

A. Ghost Guns Pose a Significant Danger to Public Safety.

To explain the impetus for its new definitions, the Final Rule pointed to “the substantial increase in the number of [ghost guns] recovered from crime scenes throughout the country in recent years”; the risk of “potentially dangerous persons . . . acquiring [weapons parts] kits and easily making functional weapons”; and the need to “enhance public safety by helping to ensure that more firearms may be traced by law enforcement to solve crime and arrest the perpetrators.” 87 Fed. Reg. at 24,656, 24,669. Amici’s experience confirms these findings and reinforces the need for more vigorous enforcement against ghost guns and ghost gun components.

1. Ghost guns have increasingly fallen into the hands of dangerous individuals who would otherwise be barred from possessing firearms.

With the growing prevalence of unregulated ghost-gun kits and the increasing accessibility of 3D printers, the number of illegal ghost guns recovered in New York City has steadily risen. In 2018, for example, the NYPD recovered only 17 ghost guns. That number increased to 48 in 2019; 150 in 2020; 263 in 2021; and 436 in 2022. After a slight dip in 2023, with 359 ghost guns recovered, authorities recovered a record 193 ghost guns through May 24, 2024—a rate that would translate into the seizure of 495 ghost guns by the year’s end. Thus, in just six years, the number of ghost guns in New York City has exploded by nearly 30 times. Although 3D-printed firearms have constituted a growing proportion of ghost guns recovered in recent years, 64.8% of ghost guns recovered from January 1 through May 24, 2024, were made from the kinds of home-assembly kits and partially completed frames and receivers that are covered by the Final Rule.

These numbers are not unique to New York City. In 2016, for example, the Bureau of Alcohol, Tobacco, and Firearms and Explosives (“ATF”) reported that 1,758 ghost guns were recovered by local law enforcement; that number increased to 19,344 in 2021. *See* 87 Fed. Reg. at 24,656. Other localities reported similar increases. Chicago, for example, recovered 2 ghost guns in 2016 and 455 in

2021.¹ Baltimore recovered 12 ghost guns in 2018 and 462 in 2023.² And Philadelphia recovered 12 ghost guns in 2018 and 575 in 2022.³

Amici's experience demonstrates that the lack of regulation governing ghost-gun kits and components has allowed these firearms to fall into the hands of dangerous individuals who would otherwise be ineligible to possess these weapons under New York law. By purchasing home-assembly kits and partially completed frames or receivers online or in other States, these individuals have been able to amass large quantities of firearms that are unserialized and therefore untraceable.

- Between October 2016 and May 2022, Jose Rivera, a Manhattan resident who was disqualified for a firearm license in New York due to a prior felony conviction for violating an order of protection, purchased more than \$7,000 worth of firearm parts, including those necessary to make home-assembled guns.

¹ See Brónagh Tumulty, "Ghost guns" seized by Chicago police steadily rising as Biden administration plans to target them, WGN9 (Apr. 8, 2021); Jeff Pegues, Rise in crime fueled in part by "ghost" guns, ATF says, CBS EVENING NEWS (Feb. 2, 2022).

² See *Social Media Post Prompts Baltimore Police To Seize Ghost Gun, Make Arrest*, MARYLAND NEWS (Feb. 6, 2022); Press Release, Mayor Baltimore City, *City of Baltimore Reaches Settlement in Polymer80* (Feb. 21, 2024), <https://mayor.baltimorecity.gov/news/press-releases/2024-02-21-city-baltimore-reaches-settlement-polymer80>.

³ See Complaint ¶ 118, *City of Philadelphia v. Polymer80 et al.*, Case No. 230700362 (Philadelphia Ct. Comm. Pleas 2023).

When the NYPD executed a search warrant at Rivera's home, officers recovered six fully assembled firearms, three of which were loaded with high capacity magazines, and one of which was an AR-15 assault rifle. Two of the firearms were easily accessible to two- and three-year-old children in the apartment.⁴

- Over a two-year period, Jeru McCray purchased enough home-assembly firearm parts to complete four handguns and one AR-15-type rifle. In McCray's apartment, the NYPD found one fully assembled pistol, one AR-15 lower receiver, and various tools that are commonly used to make home-assembled firearms. The pistol had been left unsecured in a room McCray shared with a young child. McCray was able to obtain these components and assemble firearms despite the fact that he was disqualified from having a license due to a prior conviction for second-degree aggravated harassment.⁵
- In November 2022, the NYPD recovered an arsenal of 14 ghost guns and one unfinished Polymer80 pistol frame from Cory Davis. The police searched Davis's home and office after

⁴ Statement of Facts, *People v. Rivera*, Ind. No. 74227-22 (N.Y. Cty. Sup. Ct., Oct. 11, 2022).

⁵ Press Release, New York County District Attorney, *D.A. Bragg Announces Prison Sentence for Manufacturing and Possessing Ghost Gun in UWS Apartment* (Dec. 13, 2022), <https://manhattanda.org/d-a-bragg-announces-prison-sentence-for-manufacturing-and-possessing-ghost-gun-in-uws-apartment>.

they received a report from an acquaintance who became alarmed when Davis sent a photograph of his seven-year-old son brandishing two firearms to a group chat that included Davis's friends and family.⁶

- Another Manhattan resident, Rene Loyola, purchased from several online retailers more than \$20,000 worth of home-assembly firearm parts, including more than 30 partially complete frames and receivers, over two years. From Loyola's home and storage facility unit, the NYPD recovered an arsenal of unserialized firearm parts, including 29 lower receivers.⁷

The above examples involve the types of home-assembly kits and partially complete frames or receivers that are the subject of the Final Rule. In addition, amici have seen the rise of a closely related phenomenon: the use of 3D printers to produce complete firearms or firearms components that are also unserialized and unregistered. *See* 87 Fed. Reg. at 24,656, 24,665, 24,688.

- On March 20, 2024, the police raided a 3D-printing ghost-gun factory operated by Roberto Guerrero and found promotional videos in

⁶ Press Release, New York County District Attorney, *D.A. Bragg Indicts Upper East Side Man for Manufacturing 14 Ghost Guns* (Nov. 28, 2022), <https://manhattanda.org/d-a-bragg-indicts-upper-east-side-man-for-manufacturing-14-ghost-guns>.

⁷ Statement of Facts, *People v. Loyola*, Ind. No. 71721-22 (N.Y. Cty. Sup. Ct., May 25, 2022).

which Guerrero displayed the guns he assembled by firing them in Central Park.⁸

- On September 26, 2023, law enforcement officers executed a raid at the home of Karon Coley, which was also used as a daycare center, and recovered a 3D printer, several firearm components, and multiple 3D-printed firearms, which were found in a bedroom Coley shared with a minor child.⁹
- On January 15, 2023, the police arrested Cliffie Thompson for assaulting his girlfriend and then caught him directing a woman to remove certain equipment from his East Village apartment. The next day, the police executed a search warrant at Thompson's apartment and discovered a sophisticated ghost-gun factory, including two 3D printers and several 3D-printed gun parts in various stages of completion, as well as 36 forged credit cards containing the personal identifying information of individuals other than Thompson.¹⁰

⁸ Statement of Facts, *People v. Guerrero*, Ind. No. 72178-24 (N.Y. Cty. Sup. Ct., May 28, 2024).

⁹ Statement of Facts, *People v. Coley*, Ind. No. 74957-23 (N.Y. Cty. Sup. Ct., Oct. 20, 2023).

¹⁰ Press Release, New York County District Attorney, *D.A. Bragg Announces 69-Count Indictment in Ghost Gun Factory Takedown* (Feb. 3, 2023), <https://manhattanda.org/d-a-bragg-announces-69-count-indictment-in-ghost-gun-factory-takedown>.

- On June 2, 2023, police executed a search warrant at the home of Eleazer Edelstein. A few days earlier, Edelstein had threatened to kill his girlfriend in a series of text messages and brandished a 3D-printed firearm in a FaceTime video chat with her. At Edelstein’s apartment, the police recovered two 3D printers and at least two 3D-printed pistols.¹¹

The prevalence of 3D-printed guns and components highlights the same problems addressed by the Final Rule: the growing market for untraceable weapons, and the dangerous individuals who have been able to amass an arsenal of firearms outside of the supervision of federal, state, and local laws.

2. Ghost guns are functionally equivalent to traditional guns and can be easily assembled with minimal effort.

Once assembled, firearms made from home-assembly kits are functionally indistinguishable from pre-assembled guns. The CEO and co-founder of Polymer80, Inc., one of the respondents in this proceeding, has stated that a home-assembled firearm, “when you finish it, . . . is no different than

¹¹ Press Release, New York County District Attorney, *D.A. Bragg Announces Guilty Plea of Eleazer Edelstein For Manufacturing Ghost Guns and Making Threats Against Former Girlfriend* (Dec. 18, 2023), <https://manhattanda.org/d-a-bragg-announces-guilty-plea-of-eleazer-edelstein-for-manufacturing-ghost-guns-and-making-threats>.

any other firearm.”¹² Indeed, home-assembled firearms recovered by the NYPD have typically corresponded to specific models of commercially available pre-assembled guns. For example, from January 1 to May 24, 2024, 75% of home-assembled firearms recovered were Glock-type pistols, and 20% were AR-type rifles. In 2021, 93.7% of Glock-type ghost guns recovered by the NYPD were assembled from parts manufactured by Polymer80.¹³ Consistent with those trends, 20 of the ghost-gun kits and parts purchased by defendant Rene Loyola were manufactured by Polymer80 and were designed to correspond to Glock-type pistols.¹⁴ Six corresponded to AR-15-type rifles.¹⁵

¹² *Polymer 80 CEO Loran Kelley about the Baltimore Settlement, Politics, and more*, FREE TRADE MAFIA (March 8, 2024), <https://www.youtube.com/watch?v=45ZuI04yWC4>.

¹³ The prevalence of Polymer80 Glock-type ghost guns in New York City is consistent with national trends. For example, Polymer80 manufactured 91% of all ghost guns recovered by the Baltimore Police Department between January 2020 and April 2022. Complaint ¶ 54, *Baltimore v. Polymer80, Inc. et al.*, Case No. 24-C-22-002482 (Baltimore City, Md. Cir. Ct., June 1, 2022).

¹⁴ See Statement of Facts, *Loyola*, *supra* n.7.

¹⁵ See *id.*



These kits and parts can be quickly converted into firearms without special tools or gunsmithing skills. For example, one of Polymer80's partially completed Glock-type pistol frames can be converted into a completed frame simply by drilling six holes and filing down five bits of excess plastic.¹⁶ To facilitate fast and easy assembly, the company ships the near-complete frame in an assembly "jig," which demarcates the locations where the holes will be drilled and the plastic will be filed down:¹⁷

¹⁶ See generally Bureau of Alcohol, Tobacco, Firearms and Explosives, *Open Letter to All Federal Firearms Licensees—Impact of Final Rule 2021-05F on Partially Complete Polymer80, Lone Wolf, and Similar Semiautomatic Pistol Frames* (Dec. 27, 2022).

¹⁷ Second Amended Complaint ("SAC") ¶ 43–44, *James v. Arm or Ally LLC*, Case No. 22-cv-06124 (JMF) (S.D.N.Y. March 13, 2023), ECF No. 157; Polymer80, *PF940V2 Pistol Frames, 80% Instructions 4, 7* (undated), https://polymer80.com/wp-content/uploads/2024/01/Polymer80_-_PF940v2_Series_Pistol_Kit_instructions.pdf.



The six holes, three on the front and three on the back, are drilled into the spots marked as “M3” or “M4” on the assembly jig:¹⁸

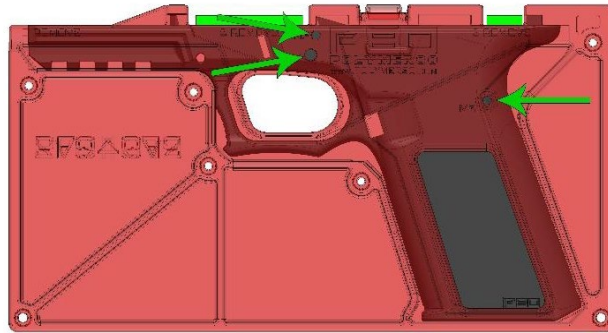

¹⁸ *PF940V2 Pistol Frames, 80% Instructions*, supra n.17, at 9.

The holes can be drilled with a power drill and a pair of drill bits that are shipped in the package along with the frame.¹⁹

The five pieces of excess plastic include one “barrel blocking tab” and four “rails,” two in the front and two in the back.²⁰ The rails are marked by the word “remove” on the assembly jig, and both the rails and the barrel blocking tab are identified with green color in the product’s assembly guide:²¹

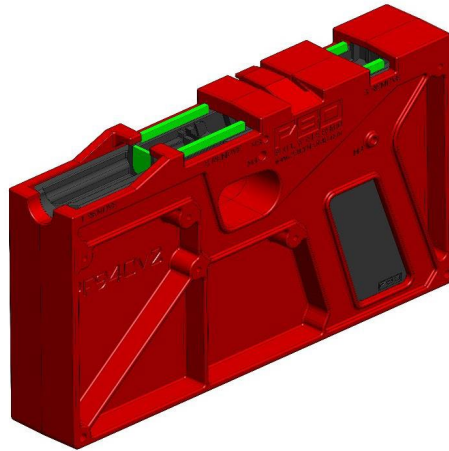

It is precisely the absence of any need for craftsmanship on the customer’s part that is often emphasized in marketing materials for home-assembled firearms. For example, 80 Percent Arms,

¹⁹ SAC ¶¶ 48-49, *James*, No. 22-cv-06124; *PF940V2 Pistol Frames, 80% Instructions*, *supra* n.17, at 9.

²⁰ *PF940V2 Pistol Frames, 80% Instructions*, *supra* n.17, at 9–11; *Open Letter to All Federal Firearms Licensees*, *supra* n. 16, at 7.

²¹ SAC ¶ 45, *James*, No. 22-cv-06124; *PF940V2 Pistol Frames, 80% Instructions*, *supra* n.17, at 7, 9–12.

another manufacturer of home-assembly firearm kits and a respondent in this proceeding, describes the requisite home-assembly steps as “a small amount of finishing.”²² A marketing video from 80 Percent Arms states that “you can do it in as little as an hour. It’s super simple. . . . Even a caveman could do this.”²³ Indeed, the 14 ghost guns recovered from defendant Cory Davis appear to have been assembled through this “super simple” process.



It is also no accident that easily assembled ghost guns have become increasingly prevalent among individuals who would otherwise be banned from possessing firearms in New York. Indeed, home-assembly firearm kits are explicitly marketed as a means of bypassing gun-control laws. For example, 80 Percent Arms describes home-assembled firearms as a “solution” for customers seeking to avoid laws on firearm sales, emphasizing: “Building your own gun . . . does not require any sort of serial number or

²² 80 Percent Arms, *What is an 80 Lower Receiver?*, <https://www.80percentarms.com/80-lowers>.

²³ 80 Percent Arms, *Build Your Own Gun in 1 Hour 100 Legal* (Aug. 20, 2018), <https://vimeo.com/285916385>.

registration. . . . There's no paperwork, no background checks, no registration, no database.”²⁴ Similarly, Polymer80 boasts that its pistol frames are in “high demand” because people who build their own guns “don't have to worry about the background check.”²⁵ Additionally, Polymer80 has acknowledged that “some consumers” purchase its products “because they place a high value on . . . the privacy afforded by owning unmarked and unserialized firearms.”²⁶ In fact, Polymer80 executives have even suggested that the prospect of sidestepping regulations governing firearm sales is the primary driver of consumer demand for the company's products, accounting for “more than fifty (50) percent, and perhaps . . . as much as seventy-five (75) percent” of its annual revenue.²⁷ And Polymer80 executives have emphasized the company's desire to prevent any information from being recorded about the customers who purchase its products and assemble firearms, touting that, when Polymer80 kits are purchased at gun shows, “[t]here's no picture taken, nothing's written down, there's no documentation of

²⁴ 80 Percent Arms, *Build Your Own Gun in 1 Hour 100 Legal*, *supra* n.23.

²⁵ Polymer80 (@polymer80inc), INSTAGRAM (April 17, 2020), https://www.instagram.com/tv/B_F9zmtPKkW/?igsh=MWh1c2Z4ZTV2cW5nOA== (last visited June 27, 2024).

²⁶ Polymer80, Inc., *Comment on Proposed Rule Entitled “Definition of ‘Frame or Receiver’ and Identification of Firearms,”* Ex. B at 18 (Aug. 19, 2021), <https://www.regulations.gov/comment/ATF-2021-0001-244128>.

²⁷ Decl. of David L. Borges in Supp. of Mot. of Polymer80, Inc. to Intervene ¶ 6, *Syracuse v. Bureau of Alcohol, Tobacco, Firearms and Explosives*, Case No. 20-cv-6885 (GHW) (S.D.N.Y. Dec. 30, 2020), ECF No. 80.

anything.”²⁸ As for kits purchased on Polymer80’s website, its executives have promised, “we actually get rid of customer data . . . we just don’t retain it.”²⁹

Thus, the ability of home-assembled firearms to skirt existing regulations is a core part of their appeal. But their functional equivalence to pre-assembled guns confirms the need for the regulatory oversight provided by the Final Rule.

B. Federal Regulation Is an Essential Complement to State and Local Efforts to Address the Proliferation of Ghost Guns.

New York has enacted a number of measures to curb the growing danger of ghost guns, including several that parallel the Final Rule. Amici have vigorously enforced those protections in New York City. But federal protections and federal enforcement remain important complements to amici’s own efforts, particularly given our experience seeing ghost guns and ghost gun parts from other States entering into the New York market. Upholding the Final Rule and preserving its protections would thus further Congress’s intent to provide “support to . . . local law enforcement officials in their fight against crime and violence.” Gun Control Act of 1968, Pub. L. No. 90-618, § 101, 82 Stat. 1213, 1213-14 (1968).

²⁸ *Polymer 80 CEO Loran Kelley about the Baltimore Settlement, Politics, and more, supra* n.12.

²⁹ *Id.*

1. New York has enacted its own restrictions on ghost guns and ghost gun components.

New York law defines a ghost gun as any “firearm, rifle or shotgun that does not comply with [state registration and serialization requirements] and is not serialized.” N.Y. Penal Law § 265.00(32). In a number of overlapping ways, state law prohibits the possession and sale of both completed ghost guns and finished or unfinished ghost gun parts.

For one thing, completed ghost guns are considered to be firearms under New York law. N.Y. Penal Law §§ 265.00(3)(a)-(c), (32). They are thus subject to New York’s comprehensive firearm licensing scheme, *see id.* § 400.00, as well as its prohibitions on criminal possession of a weapon, *see id.* § 265.01 et seq.

In 2021, the New York Legislature supplemented these existing laws by enacting additional measures specifically addressing ghost guns. *See* 2021 N.Y. Laws Chs. 519-520. One such measure made it unlawful to possess or sell any “unfinished frame or receiver,” defined as “any unserialized material” that is not itself a frame or receiver “but that has been shaped or formed in any way for the purpose of becoming the frame or receiver of a firearm, rifle or shotgun, and which may readily be made into a functional frame or receiver through milling, drilling or other means.” N.Y. Penal Law § 265.00(32); *see also id.* §§ 265.01(10) (prohibiting possession), 265.63–265.64 (prohibiting sale). This prohibition was intended to close the “dangerous

loophole[]” that allowed an individual to use unfinished frames and receivers to “circumvent gun laws by making their own semiautomatic weapon at home.” Introducer’s Mem. 2, *reprinted in* Bill Jacket for Ch. 519, at 8 (2021).

The Legislature also made it a separate crime to possess or sell a ghost gun. It is thus a misdemeanor to possess a ghost gun and a felony to sell, exchange, give, or dispose of a ghost gun. N.Y. Penal Law §§ 265.01(9), 265.60. More severe penalties are available if an individual sells ten or more ghost guns. *Id.* § 265.61.

Although New York law does not currently prohibit the manufacture of ghost guns or ghost gun parts, state lawmakers, working in collaboration with amici, have introduced measures that would authorize this additional enforcement measure as well. *See* N.Y. Senate Bill No. 7364-A (2023-2024); N.Y. Assembly Bill No. 7489-A (2023-2024). Those proposals would make it a felony to manufacture or cause to be manufactured any ghost gun or unfinished frame or receiver. *See* N.Y. Senate Bill No. 7364-A, § 1. And they would further prohibit the sale of digital instructions to program a 3D printer to manufacture a ghost gun or unfinished frame or receiver. *See id.* These proposals recognize that ghost guns “continue to be a major threat to the safety of New Yorkers” and aim to ensure that state law remains “responsive to the technology perpetrators may use” to illegally traffic in ghost guns. Sponsor’s Mem., N.Y. Senate Bill No. 7364-A.

Since February 2020, New York City has also prohibited the possession, sale, transfer, or offering for sale of an “unfinished frame or receiver” by or to a person in New York City. N.Y.C. Admin. Code § 10-314; *see also id.* § 10-301(8). An “unfinished frame or receiver” is defined as a “piece of any material that does not constitute the frame or receiver of a firearm, rifle, shotgun, or assault weapon but that has been shaped or formed in any way for the purpose of becoming the frame or receiver of a firearm, rifle, shotgun, or assault weapon with modification by the user and that is not engraved with a serial number.” N.Y.C. Admin. Code § 10-301(22). A violation of this provision is a misdemeanor. *Id.* § 10-314.

2. Amici have vigorously enforced state and local laws to halt the spread of ghost guns.

Amici are actively engaged in the enforcement of state and local laws to prevent the proliferation of ghost guns in New York City.

For instance, since 2020, the New York County District Attorney’s Office has worked with its partners in the Ghost Gun Initiative to proactively and preemptively identify ghost gun builders and traffickers in the City. The Initiative invests in research to identify growing ghost gun trends, including 3D-printed ghost gun technology, the rising popularity of ghost guns among youth, the intersection between domestic extremism and ghost guns, and the use of financial fraud to further obfuscate illegal ghost gun activities. The Initiative has developed investigative methods and models that

are tailored to addressing these unique problems and preventing ghost guns from gaining further foothold in the City. The Initiative also trains other police departments and prosecutors' offices around the country in proactive ghost gun investigations.

For its part, the NYPD established a special team in 2020 dedicated exclusively to stopping the flow of ghost guns to New York City before they reach city streets and to recover ghost guns illegally possessed in the City. The Major Case Field Intelligence Team, operating under the Commanding Officer of the NYPD's Field Intelligence Program, works with federal, state, and local law enforcement and prosecutors on in-depth ghost gun investigations, search warrant executions, and arrests; it also conducts ghost gun-related trainings for police officers and prosecutors. The team is comprised of one full-time Field Intelligence Captain, one full-time NYPD Field Intelligence Sergeant, and six full-time detectives serving as Field Intelligence Officers, and it is supported by three civilian criminal analysts. *See* Complaint ¶ 48, *City of New York v. Arm or Ally et al.*, No. 22-cv-05525 (S.D.N.Y. June 29, 2022), ECF No. 1 ("City Compl.").

These efforts have resulted in dozens of prosecutions throughout the City involving the seizure of hundreds of ghost guns and ghost gun parts. The cases described above are just a few illustrative examples. To date, the New York County District Attorney's Ghost Guns Initiative has prosecuted cases involving the seizure of over 165 ghost gun parts, 94 firearms, 444 high-capacity

magazines, 49 silencers, and other gear including scopes and rapid-fire modification devices.

Amici's enforcement actions have extended beyond weapon seizures and criminal prosecutions. For instance, in April 2024, the New York County District Attorney sent a letter to YouTube expressing concerns about that website's hosting of videos on how to make and manufacture ghost guns, as well as its algorithms that push these videos onto the screens of young children.³⁰ In response, YouTube issued new guidance that specifically prohibits videos that provide instructions on how to remove certain firearm safety devices. And the company created new categories of age-restricted content that cannot be shown to viewers under eighteen, including content showing the use of a homemade firearm or automatic firearm and its accessories.³¹

Separately, in 2022, the dramatic rise in the criminal use of untraceable ghost guns led the City of New York to begin investigating whether out-of-state online ghost gun retailers were selling ghost gun components to City residents in violation of state and local laws prohibiting their possession and sale. Using a fictitious name, undercover investigators with the

³⁰ See Letter from District Attorney Alvin Bragg to Neal Mohan (Apr. 24, 2024), <https://manhattanda.org/wp-content/uploads/2024/04/DA-Bragg-Letter-to-Neal-Mohan.4.24.24.pdf>.

³¹ See Press Release, New York County District Attorney, *D.A. Bragg Applauds YouTube For Changing Firearm Content Guidelines In Response To Advocacy From Office* (June 5, 2024), <https://manhattanda.org/d-a-bragg-applauds-youtube-for-changing-firearm-content-guidelines-in-response-to-advocacy-from-office/>.

New York City Sheriff's Office placed online orders with several out-of-state retailers for unfinished frames and other ghost gun components. City Compl. at 21-28. In each case, the investigators asked the retailer to deliver the component to an address in Manhattan. *Id.* In every instance, the retailer did so, without performing a background check and without confirming whether the investigator had a valid handgun license or permit. *Id.* Sheriff's Office investigators then attempted to assemble a complete ghost gun using the parts they had acquired online. Decl. of Francesca Rosa, *City of New York v. Arm or Ally et al.*, No. 22-cv-05525 (S.D.N.Y. June 29, 2022), ECF No. 6 at 2-3. They were able to do so easily, using standard household tools and online instruction booklets, in just an hour and a half. *Id.* at 3-5. When the investigators tested the newly constructed guns at a police firing range, they found them fully operational. *Id.* at 5-6.

Based on the results of that investigation, the City filed a lawsuit in the Southern District of New York against five out-of-state online retailers of ghost gun components—Arm or Ally, Rainier Arms, 80P Builder, Rock Slide USA, and Indie Guns—alleging that their actions violated state and city law, as well as statutory and common law prohibitions on public nuisances. The complaint alleged that, in addition to their sales to the undercover investigator, the retailers had collectively shipped hundreds of packages containing illegal frames and receivers to addresses in New York City and State, some of which were shipped to City residents who were later arrested for possessing illegal ghost guns. City Compl. at 20, 22, 24. The complaint further alleged that the

retailers’ actions “result[] in a proliferation of unserialized, untraceable, unlawful ghost guns in the City’s streets and homes, making the City more dangerous for both the public and for law enforcement, causing a quintessential public nuisance” and violating City and State laws prohibiting the possession and sale of unfinished frames and receivers. *Id.* at 3. New York City also alleged that “evasion” of federal regulations governing firearms is “the core of [the retailers] business model,” since the “appeal of ghost guns is rooted largely, if not entirely, in their purported status as outside the reach of the firearms laws.” *Id.* at 8.

Shortly after the lawsuit was filed, the City entered into settlement agreements with four of the five retailers, in which they agreed to stop selling ghost gun components to New York City residents.³² In October 2022, the district court granted the City’s motion for a preliminary injunction as to the final retailer—Indie Guns—and barred it from selling its products to New Yorkers.³³ The City later obtained a

³² Press Release, Office of the Mayor, *Mayor Adams Stops Two Ghost Gun Retailers From Selling Ghost Gun Kits To NYC Residents* (Aug. 25, 2022), <https://perma.cc/7HNW-GE48>; Press Release, Office of the Mayor, *Mayor Adams Stops Additional Ghost Gun Retailer from Selling Ghost Gun Kits to NYC Residents* (Sept. 6, 2022), <https://perma.cc/4K4Y-55NG>; Press Release, Office of the Mayor, *Mayor Adams Stops Additional Ghost Gun Retailer from Selling Ghost Gun Kits to NYC Residents* (Oct. 13, 2022), <https://perma.cc/UT4Z-82A6>.

³³ Press Release, Office of the Mayor, *Mayor Adams Successful in Halting Online Ghost Gun Retailer Indie Guns*

permanent injunction. *City of New York v. Arm or Ally et al.*, No. 22-cv-05525 (S.D.N.Y. Mar. 27, 2023), ECF No. 102. Those settlements—and the injunctions against Indie Guns—represent significant victories for the City in its battle against the scourge of untraceable ghost guns.

3. Federal regulation can address interstate sales of ghost guns and ghost gun parts and prevent circumvention of state and local restrictions.

Amici’s efforts have had a meaningful impact. But they are not enough. Our experience confirms that federal regulation in this area has served as a critical tool to supplement local enforcement efforts. The Fifth Circuit’s decision wrongly deprives amici of a particularly helpful tool—one that was designed to “assist[] State and local law enforcement in their efforts to control the traffic of firearms within their borders.” 87 Fed. Reg. at 24,659.

In this respect, the Final Rule breaks no new ground. Federal regulation of firearms has long been understood as an indispensable means of supporting local efforts to combat violent crime. When Congress enacted the National Firearms Act of 1938, for instance, one of its principal aims was to “aid state and local efforts at tighter control by prohibiting transactions that would violate local laws.” Franklin E. Zimring, *Firearms and Federal Law: The Gun Control Act of 1968*, 4 J. Legal Stud. 133, 140 (1975).

from Unlawfully Selling Kits to NYC Residents (Oct. 27, 2022), <https://perma.cc/UF6F-3THZ>.

And the Gun Control Act of 1968 was intended to “provide support to Federal, State, and local law enforcement officials in their fight against crime and violence.” Pub. Law No. 90-618, § 101, 82 Stat. at 1213-14. As Congress explained, the Act’s “principal purpose” was to “strengthen Federal controls over interstate and foreign commerce in firearms and to assist the States effectively to regulate firearms traffic within their borders.” H.R. Rep. 90-1577, *reprinted in* 1968 U.S.C.C.A.N. 4410, 4411 (1968). Pointing to the violent murders of President John F. Kennedy, Rev. Martin Luther King Jr., Medgar Evers, and others committed by rifles and shotguns, Congress explained that the Act was “designed effectively to control the indiscriminate flow of such weapons across State borders and to assist and encourage States and local communities to adopt and enforce stricter gun control laws.” H.R. Rep. 90-1577, *reprinted in* 1968 U.S.C.C.A.N. at 4413.

In a letter supporting enactment of the Act, U.S. Attorney General Ramsey Clark put the matter more bluntly: federal action was necessary to stop “mail order murder.” The Attorney General “recogniz[ed] the Federal responsibility to control the indiscriminate flow of firearms and ammunition across State borders” and urged enactment of the Act as a way to give “States and local communities the capacity and the incentive to enforce effectively their own gun control laws.” By regulating the interstate commerce in firearms, he argued, the Act would ensure “that strong local or State laws are not subverted by a deadly interstate traffic in firearms and ammunition.” H.R. Rep. 90-1577, *reprinted in* 1968 U.S.C.C.A.N. at 4425 (quoting Letter from the

U.S. Attorney General). As one Senator noted, “[w]ithout such Federal assistance, any State gun law can be subverted by any child, fugitive, or felon who orders a gun by mail or buys one in a neighboring State which has lax gun laws.” 114 Cong. Rec. 13647 (1968) (statement of Sen. Joseph Tydings).

Our experience confirms the critical importance of federal regulation to curb the interstate flow of firearms, including ghost guns and ghost gun components. Without a national solution, ghost guns inevitably find their way from other jurisdictions with fewer restrictions or less robust enforcement into the hands of criminals in New York City. Indeed, ghost-gun manufacturers have admitted their intention to circumvent state laws restricting the sale of their products: in comments to a committee of the Arizona Legislature considering a ban on unfinished frames and receivers, for instance, the owner of Polymer80—a major manufacturer of ghost-gun kits—testified that he did not “care if this bill passes” because his company “just will not comply with it no matter what you do.” Minutes of the Meeting of the Arizona Assembly Committee on Judiciary 45 (Mar. 17, 2021).

In many of the prosecutions brought by the New York County District Attorney’s Office, defendants were found with ghost guns or ghost gun components that they purchased outside of the State. For example, defendant Rene Loyola—who was caught with 29 lower receivers and 293 high capacity magazines—purchased many of these illegal ghost-gun components from online retailers without any background or license check, and had high capacity magazines delivered to an out-of-state address in

Pennsylvania to circumvent New York's prohibition on such shipments.³⁴ Similarly, defendant Jeru McCray purchased a large volume of ghost-gun parts that were shipped to his residence; he also had additional firearms parts and ammunition shipped to an address in Pennsylvania.³⁵

These examples illustrate the ways in which criminals have sought to circumvent state and local restrictions by obtaining ghost guns and ghost gun parts online or from other jurisdictions. The ease of such transactions, particularly with the growth of sales over the Internet, reinforces the need for federal regulation to stem the traffic of illegal ghost guns.

³⁴ See Statement of Facts, *Loyola*, supra n.7.

³⁵ See *D.A. Bragg Announces Prison Sentence for Manufacturing and Possessing Ghost Gun in UWS Apartment*, supra n.5.

CONCLUSION

This Court should reverse the decision of the Fifth Circuit.

Respectfully submitted,

MURIEL GOODE-TRUFANT <i>Acting Corporation Counsel of the City of New York</i>	ALVIN L. BRAGG <i>District Attorney New York County</i>
RICHARD DEARING <i>Chief, Appeals Division</i>	STEVEN C. WU* <i>Chief, Appeals Division</i>
CLAUDE S. PLATTON <i>Deputy Chief, Appeals Division</i>	PHILIP V. TISNE BRENT YARNELL <i>Assistant District Attorneys</i>
PHILIP YOUNG <i>Senior Counsel</i>	(212) 335-9326 wus@dany.nyc.gov

* *Counsel of Record*

July 2, 2024