

No. \_\_\_\_\_

---

---

**In the  
Supreme Court of the United States**

---

**ESIP SERIES 2, LLC,**  
*Petitioner,*

v.

**PUZHEN LIFE USA, LLC,**  
*Respondent.*

---

**ON PETITION FOR WRIT OF CERTIORARI TO  
THE UNITED STATES COURT OF APPEALS  
FOR THE FEDERAL CIRCUIT**

---

**APPENDIX TO CORRECTED  
PETITION FOR WRIT OF CERTIORARI**

---

**Gordon K. Hill**  
*Counsel of Record*

**Alma J. Pate**  
**PATE BAIRD**  
**36 West Fireclay Avenue**  
**Salt Lake City, UT 84107**  
**(801) 284-7000**  
**ghill@patebaird.com**

***Counsel for Petitioner***

---

---

*Gibson*Moore Appellate Services, LLC  
206 East Cary Street ♦ Richmond, VA 23219  
804-249-7770 ♦ [www.gibsonmoore.net](http://www.gibsonmoore.net)

**TABLE OF CONTENTS**  
**Appendix to Petition**

**Page:**

Opinion U.S. Court of Appeals for the Federal Circuit <i>ESIP Series 2, LLC v. Puzhen Life USA, LLC</i> (No.2019-1659) entered May 19, 2020.....	1a
Patent Board Decision and Order entered February 27, 2019.....	15a
Order Denying Petition for Panel Rehearing and Rehearing en Banc U.S. Court of Appeals for the Federal Circuit <i>ESIP Series 2, LLC v. Puzhen Life USA, LLC</i> (No.2019-1659) entered July 13, 2020.....	81a
Relevant Constitutional and Statutory Provisions:	
U.S. Const. amend. V .....	83a
Title 5 USC .....	83a
Title 35 USC .....	84a

**[ENTERED: May 19, 2020]**

United States Court of Appeals  
for the Federal Circuit

---

**ESIP SERIES 2, LLC,**  
*Appellant*

v.

**PUZHEN LIFE USA, LLC,**  
*Appellee*

---

2019-1659

---

Appeal from the United States Patent and  
Trademark Office, Patent Trial and Appeal Board in  
No. IPR2017-02197.

---

Decided: May 19, 2020

---

GORDON K. HILL, Pate Baird, Salt Lake City, UT,  
argued for appellant. Also argued by  
ALMA JOHN PATE.

MARK A. MILLER, Dorsey & Whitney LLP, Salt  
Lake City, UT, argued for appellee. Also represented  
by ELLIOT HALES; GREGORY STUART SMITH,  
Law Offices of Gregory S. Smith, Washington, DC.

---

Before LOURIE, REYNA, and HUGHES, *Circuit  
Judges.*

REYNA, *Circuit Judge.*

ESIP Series 2, LLC, appeals a decision of the Patent Trial and Appeal Board that certain claims of ESIP's patent are invalid as obvious. ESIP also contends that the Board should not have instituted inter partes review because appellee Puzhen failed to identify "all real parties in interest" as required by 35 U.S.C. § 312. We find no error in the Board's obviousness determination, and the Board's decision to institute inter partes review is final and non-appealable. We affirm.

#### BACKGROUND

##### A. The '130 Patent

ESIP Series 2, LLC, ("ESIP") owns U.S. Patent No. 9,415,130 ("the '130 patent"), which relates to "a novel system and method for combining germicidal protection and aromatic diffusion in enclosed habitable spaces." '130 patent at 1:7–10. Products of this type are commonly known as "vaporizers" or "diffusers." Figure 2 of the '130 patent, shown below, depicts an embodiment of the claimed invention with a diffusion module (45) contained within a housing (12).

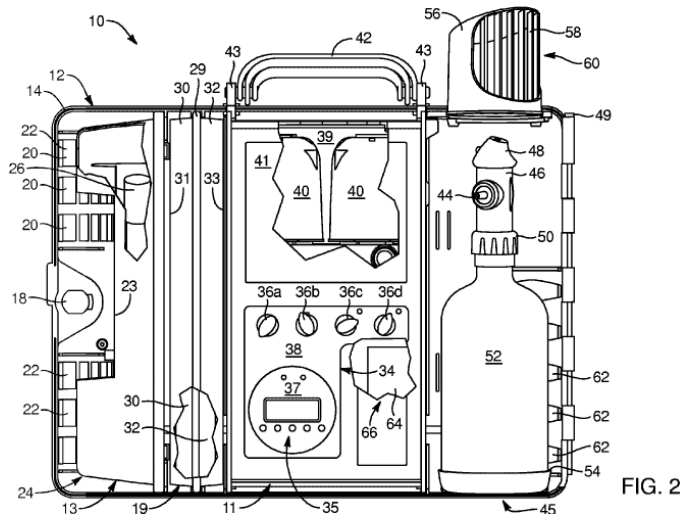

FIG. 2

The '130 patent states that it overcomes “a number of problems” in the prior art that stem from the diffusion of “[o]verly large particles.” '130 patent at 4:15–28. It teaches that overly large particles cause waste and reduce effectiveness: “rather than remaining in the air until they have evaporated or been incorporated into the atmosphere, they may instead settle out relatively quickly, onto surfaces, furniture, floors, into HVAC systems, or the like.” *Id.*

To avoid these problems, the claimed invention recites “a micro-cyclone for quiet, well diffused flow of ultra-fine droplets.” '130 patent at 4:15–28. Figure 12, shown below, depicts components of the diffusion module (45), including: a “reservoir” (52), an “atomizer” (46), and a “micro-cyclone” (90). The micro-cyclone contains a “spiral channel” (91) that “begins below a central plane . . . defined by a plate” (96). *Id.* at 16:57–17:4. The micro-cyclone causes “the comparatively larger particles in the stream of air . . . to smash and coalesce against the inside of the outer

wall of the [spiral] channel,” leaving only “the comparatively smallest range of droplets [to be] passed out to the nozzle.” *Id.* at 17:26–31. After coalescing, the larger droplets “drip back into the atomizer . . . to be re-atomized.” *Id.*

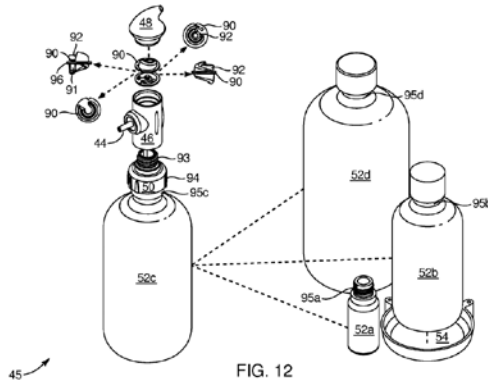

FIG. 12

Claim 1, reproduced below, illustrates the claimed invention:

1. A method for introducing a scent into breath- able air, the method comprising;
  - providing a system comprising a reservoir, eductor, and separator operably connected to one another;
  - providing a liquid constituting an aromatic substance selected by an operator for the scent to be introduced into the breathable air;
  - drawing a first portion of the liquid from the reservoir by the eductor passing a flow of air;
  - entraining the first portion of the liquid into the flow;

forming droplets of the first portion by at least one of restricting an area through which the flow passes and the entraining;

***separating*** out a second distribution of the droplets by passing the flow through a wall between a first chamber and a second chamber, the flow path spiraling axially and circumferentially, simultaneously and continuously, ***through an arcuate channel formed through the wall***; and passing a first distribution of the droplets out of the separator into the breathable air.

'130 patent at 23:22–41 (emphases added).

#### B. IPR Proceeding

Puzhen Life USA, LLC, (“Puzhen”) filed a petition for inter partes review of claims 1, 3, and 17 of the '130 patent. Puzhen challenged the claims as obvious (i) in view of Sevy<sup>1</sup> and Cronenberg<sup>2</sup>; and (ii) in view of Sevy and Giroux<sup>3</sup>.

Sevy relates to “novel systems and methods for integrating air supplies, reservoirs and atomizers into an integrated system.” Sevy at 1:6–8. Sevy relies on “direction change and momentum of impact to further comminute [] droplets into a more finely atomized mist.” *Id.* at 2:13–19. Sevy teaches that larger droplets are separated from the mist because they “cannot move with the airflow, typically

---

<sup>1</sup> U.S. Patent No. 7,878,418 (“Sevy”).

<sup>2</sup> U.S. Patent No. 4,243,396 (“Cronenberg”).

<sup>3</sup> U.S. Patent No. 8,001,963 (“Giroux”).

because . . . they will not be able to quickly turn to follow the flow of air.” *Id.* at 8:64–9:4.

Cronenberg relates to “[a] separator adapted for use as part of a fluid dispenser system for supplying inhalable fluids.” Cronenberg at Abstract. Cronenberg teaches that the “separator is adapted to be positioned within the fluid dispenser system so that the mixture of liquid and gas passes along [a] tortuous passageway,” causing “the larger droplets of liquid [to be] removed from the mixture.” *Id.* at 2:48–55. In this way, the separator “achieve[s] the desired vapor and avoid[s] the presence of liquid droplets in the gas and liquid mixture.” *Id.* at 1:20–22.

Giroux relates to “a novel integrated nebulizer and particle dispersion chamber” that “provides for delivery of a vortical flow of nebulized particles to the nostrils.” Giroux at Abstract. To achieve the size and velocity characteristics that are important for effective drug delivery, Giroux teaches forcing the particles to flow through a “baffle” that is in a “generally serpentine or helix shape,” which “create[s] motion of the nebulized particles in a vortex as they exit the dispersion chamber.” *Id.* at 13:32–42.

Based on the prior art and expert testimony, the Board determined that the challenged claims would have been obvious in view of Sevy and Cronenberg and in view of Sevy and Giroux. J.A. 40, 47. The Board found that Sevy discloses every element of the challenged claims except for the “arcuate channel” limitation of the “separating” claim element. J.A. 23–31. The Board found that both Cronenberg and



Giroux disclose the “arcuate channel” limitation. The Board explained:

[N]either reference, considered by itself, teaches forming an arcuate channel through a wall for the purpose of separating liquid droplets out of a mixed air-droplet flow. Sevy’s separator passes flow through a wall, but not using an arcuate passage-way. Cronenberg [and Giroux] teach[] accomplishing the same type of separation using an arcuate passageway, but not one passing through a wall.

J.A. 27, 43. The Board determined that a skilled artisan would have been motivated to combine the teachings of each reference with Sevy to arrive at the claimed invention.

The Board also addressed in its final written decision ESIP’s argument that Puzhen’s petition was barred from institution because Puzhen failed to identify “all real parties in interest” as required by 35 U.S.C. § 312(a)(2). J.A. 849. According to ESIP, Puzhen’s petition failed to identify two real parties in interest: doTERRA International, LLC, and Puzhen Life Co., Ltd. J.A. 5. After considering ESIP’s asserted evidence, the Board determined that neither party was a real party in interest within the meaning of 35 U.S.C. § 312(a)(2) and that Puzhen’s petition was not barred from institution. J.A. 11, 14.

#### ANALYSIS

Obviousness is a question of law with underlying factual findings relating to the scope and content of the prior art; differences between the prior art and the claims at issue; the level of ordinary skill in the

pertinent art; the presence or absence of a motivation to combine or modify prior art with a reasonable expectation of success; and any objective indicia of non-obviousness. *Persion Pharms. LLC Alvogen Malta Operations Ltd.*, 945 F.3d 1184, 1189 (Fed. Cir. 2019). We review factual determinations for substantial evidence. *Id.* Substantial evidence is “such relevant evidence as a reasonable mind might accept as adequate to support a conclusion.” *Consol. Edison Co. v. NLRB*, 305 U.S. 197, 229 (1938). We review the Board’s legal conclusions de novo. *Velander v. Garner*, 348 F.3d 1359, 1371 (Fed. Cir. 2003).

#### A. Obviousness

ESIP challenges four fact findings underlying the Board’s conclusion that the ’130 patent claims would have been obvious. We determine that all four fact findings are supported by substantial evidence, and we affirm the Board’s conclusion.

First, with respect to the “separating” claim limitation, ESIP challenges the Board’s finding that Sevy teaches separating droplets by passing the flow through an orifice in a wall. Appellant Br. 27–28. ESIP argues that Sevy’s orifice—aperture 99, shown in Figure 7 below—“does not function as a separator” because it “cannot discriminate with regard to the size of a particle passing through it. It’s a hole.” *Id.* at 28. We disagree. In support of its finding, the Board relied on Sevy’s disclosure that “separator plate 98 passes the flow of air from the atomizer 16 through apertures 99” and that droplets with “too large a size and mass will not be able to quickly turn to follow the flow of air, and will strike the walls of the opening 100 or the separator plate 98.” J.A. 26

(citing *Sevy* at 8:64–9:2). The Board also relied on the testimony of Puzhen’s expert, Mr. Smith, who testified that the separator plate (98) in *Sevy* “segregate[s]” atomizer droplets. *Id.* (citing J.A. 634–635).

We find no error in the Board’s decision to credit the opinion of one expert over another, and we do not reweigh evidence on appeal. *Impax Labs. Inc. v. Lannett Holdings Inc.*, 893 F.3d 1372, 1382 (Fed. Cir.

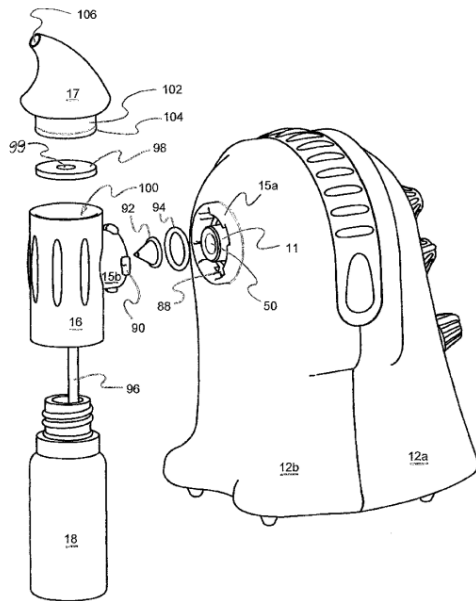

FIG-7

2018). Substantial evidence supports the Board’s finding that *Sevy* teaches separating droplets by passing the flow through an orifice in a wall.

Second, also with respect to the “separating” claim limitation, ESIP challenges the Board’s finding that Giroux discloses a “vortex” that separates large droplets from the air flow. ESIP argues that the

circulation of particles through Giroux's "vortex" "does not result in the larger droplets being separated from the vortex or separated from the air flow." Appellant Br. at 35. For support, ESIP cites only the testimony of its expert, Dr. Bell, which the Board found to be "conclusory and unsupported" and thus "un- helpful and unpersuasive." J.A. 29. In support of its finding that Giroux's vortex separates large droplets from the airflow, the Board relied on the expert testimony of Mr. Smith and Giroux's teaching that the swirl of droplets in Giroux's "vortex" "sends the larger droplets to the outside rings and . . . keeps the smaller [] droplets in the air stream for a longer period of time." J.A. 43 (quoting Giroux at 8:60-62, 12:33-37; J.A. 643-644). Substantial evidence therefore supports the Board's finding that Giroux teaches a vortex that separates larger droplets from the air flow. *See Impax*, 893 F.3d at 1382.

Third, ESIP challenges the Board's finding that a skilled artisan would have been motivated to replace the aperture in Sevy with the arcuate passageway of Cronenberg. The Board found that Sevy and Cronenberg teach two alternative methods for achieving the separation of droplets from the mixed dropletair flow, and that a skilled artisan would have been motivated to substitute one method for the other. J.A. 26-27. ESIP argues that Sevy and Cronenberg "achieve different results" and that combination of these two references would require "substantial reconstruction." Appellant Br. 28-29. Again, ESIP relies solely on the discredited testimony of Dr. Bell. In reaching its finding, the Board relied on the disclosures of Sevy and Cronenberg, and the expert testimony of Mr. Smith,

who testified that a skilled artisan “would [have] replace[d] [Sevy’s] aperture(s) in plate 98 with the helical pathway of Cronenberg.” J.A. 26 (citing Sevy at 8:64–9:2; Cronenberg at 3:12–21, 5:37–43; J.A. 634–635). Substantial evidence therefore supports the Board’s finding that a skilled artisan would be motivated to combine Sevy and Cronenberg. *See Impax*, 893 F.3d at 1382.

Fourth, ESIP challenges the Board’s finding that a skilled artisan would have been motivated to combine Sevy with Giroux. Appellant Br. 36. ESIP asserts that the Board “failed to articulate the required explication as to why Giroux’s helical baffle would be ‘formed through a wall’ as required by the subject claims.” *Id.* We disagree. The Board found that “both Sevy and Giroux teach methods for removing large droplets from [the] mixture of air and liquid droplets,” and thus a skilled artisan would have been motivated to “substitute a channel defined by a helical baffle, as taught by Giroux, for the straight orifice in Sevy’s plate.” J.A. 44–45. In reaching that determination, the Board relied on the disclosures of Sevy and Giroux, and the expert testimony of Mr. Smith, who testified that a skilled artisan “would have had a reason to combine the teachings of Sevy with those of Giroux.” *Id.* (citing Sevy at 8:64–9:2; Giroux at 8:60–62, 12:33–37; J.A. 643–644). Substantial evidence therefore supports the Board’s finding that a skilled artisan would be motivated to combine Sevy and Giroux. *See Impax*, 893 F.3d at 1382.

ESIP also argues that the Board committed numerous legal errors when rendering its obviousness determination. For example, ESIP claims that the Board legally erred by failing to

expressly define the applicable level of ordinary skill in the art. Appellant Br. 19–20. Yet ESIP fails to make the requisite showing that there are “any meaningful differences” between the parties proposed definitions or that “the outcome of [the] case would have been different based on which definition the Board used.” *Genzyme Therapeutic Prod. Ltd. P’ship v. Biomarin Pharm. Inc.*, 825 F.3d 1360, 1371–72 (Fed. Cir. 2016). Similarly, ESIP challenges the Board’s construction of “wall,” yet ESIP “fail[s] to clearly explain what result would occur if this court adopted [the appellant’s] proposed claim construction[.]” *Fresenius USA, Inc. v. Baxter Int’l, Inc.*, 582 F.3d 1288, 1304 (Fed. Cir. 2009) (holding that the appellant “gave this court little guidance and cited no record support regarding why a modified claim construction would affect the [judgment]. For that reason alone, we may decline to consider Fresenius’s claim construction arguments.”). We find ESIP’s arguments unpersuasive.

Because the Board’s obviousness conclusion is not legally erroneous and the fact findings are supported by substantial evidence, we affirm the determination that claims 1, 3, and 17 would have been obvious in view of Sevy and Cronenberg and in view of Sevy and Giroux.

#### B. Real Party in Interest

Under 35 U.S.C. § 312(a), a petition “may be considered only if” it includes: (1) payment of fees; (2) identification of all real parties in interest; (3) identification “with particularity” of each claim challenged, the grounds of each challenge, and the supporting evidence; (4) other information the

Director requires by regulation; and (5) copies of these documents for the patent owner. ESIP argues that Puzhen failed to identify all “real parties in interest” and thus the Board erred when it considered institution of inter partes review. For the reasons stated below, the Board’s § 312(a)(2) real-party-in-interest determination is final and non-appealable.

In *Cuozzo Speed Techs., LLC v. Lee*, 136 S. Ct. 2131 (2016), the Supreme Court held that this Court is precluded from reviewing Board decisions concerning the “particularity” requirement under § 312(a)(3). The Court explained that § 314(d) bars appellate review of “questions that are closely tied to the application and interpretation of statutes related to the Patent Office’s decision to initiate inter partes review.” *Id.* at 2141–42. The Court further explained that “where a patent holder grounds its claim in a statute closely related to that decision to institute inter partes review, § 314(d) bars judicial review.” *Id.*

More recently, in *Thryv, Inc v. Click-To-Call Techs., LP*, 140 S. Ct. 1367 (2020), the Supreme Court held that § 314(d) also precludes judicial review of the agency’s decision whether to apply the one-year time bar set forth in § 315(b)). The Court explained that “§ 315(b)’s time limitation is integral to, indeed a condition on, institution,” and that “a contention that a petition fails under § 315(b) is a contention that the agency should have refused ‘to institute an inter partes review.’” *Id.* at 1373–74 (quoting 35 U.S.C. § 314(d)). The Court concluded that a challenge to a petition’s timeliness under § 315(b) raises “an ordinary dispute about the

application of” an institution-related statute and is barred from appellate review by § 314(d). *Id.*

In view of *Cuozzo* and *Click-to-Call*, we find no principled reason why preclusion of judicial review under § 314(d) would not extend to a Board decision concerning the “real parties in interest” requirement of § 312(a)(2). ESIP’s contention that the Board failed to comply with § 312(a)(2) is “a contention that the agency should have re- fused to institute an inter partes review.” *See Click-To-Call*, 140 S. Ct. at 1373–74. Indeed, ESIP expressly argues that the agency should have refused to institute inter partes review because of Puzhen’s failure to identify all “real parties in interest.” *E.g.*, Appellant Br. at 5 (“[I]t was improper for the Board to ‘consider’ the IPR Petition and institute an IPR.”). Accordingly, we hold that ESIP’s challenge to the Board’s “real parties in interest” determination “raises ‘an ordinary dispute about the application of an institution-related statute,” and that § 314(d) precludes our review of that determination. *Click-To-Call*, 140 S. Ct. at 1373–74 (quoting *Cuozzo*, 136 S. Ct. at 2141–42).

#### CONCLUSION

We have considered ESIP’s other arguments and find them unpersuasive. We affirm the Board’s determination that claims 1, 3, and 17 of the ’130 patent are invalid as obvious.

**AFFIRMED**



**[ENTERED: FEBRUARY 27, 2019]**

UNITED STATES PATENT AND  
TRADEMARK OFFICE

---

BEFORE THE PATENT TRIAL  
AND APPEAL BOARD

---

PUZHEN LIFE USA, LLC,  
Petitioner,

v.

ESIP SERIES 2, LLC,  
Patent Owner.

---

Case IPR2017-02197  
Patent 9,415,130 B2

---

Before CHRISTOPHER L. CRUMBLEY, JON B.  
TORNQUIST, and CHRISTOPHER M. KAISER,  
*Administrative Patent Judges.*

KAISER, *Administrative Patent Judge.*

FINAL WRITTEN DECISION  
*35 U.S.C. § 318; 37 C.F.R. § 42.73*

## INTRODUCTION

### *A. Background*

Puzhen Life USA, LLC (“Petitioner”) filed a Petition (Paper 1, “Pet.”) requesting an *inter partes* review of claims 1, 3, and 17 of U.S. Patent No. 9,415,130 B2 (Ex. 1001, “the ’130 patent”). ESIP

Series 2, LLC (“Patent Owner”)<sup>1</sup> filed a Preliminary Response (Paper 5, “Prelim. Resp.”). On March 9, 2018, we instituted trial on all challenged claims and all grounds asserted in the Petition. Paper 10 (“Inst. Dec.”). During the trial, Patent Owner filed a Response (Paper 15, “PO Resp.”), and Petitioner filed a Reply (Paper 17). In addition, Patent Owner filed a motion to exclude certain evidence and pleadings (Paper 19), to which Petitioner filed an Opposition (Paper 20) and Patent Owner filed a Reply (Paper 22). We held a hearing, the transcript of which has been entered into the record. Paper 23 (“Tr.”).

We have jurisdiction under 35 U.S.C. § 6, and we issue this Final Written Decision pursuant to 35 U.S.C. § 318(a) and 37 C.F.R. § 42.73. We conclude that Petitioner has established by a preponderance of the evidence that claims 1, 3, and 17 of the ’130 patent are unpatentable.

#### *B. Related Matters*

The parties note that the ’130 patent is at issue in *ESIP Series 1, LLC v. doTERRA Int’l, LLC*, Case No. 2:16-cv-01011 (D. Utah). Pet. 3; Paper 4, 2.

---

<sup>1</sup> The Petition names Earl Sevy, the inventor of the ’130 patent, as the Patent Owner. Pet. 1. Patent Owner made of record in this proceeding an instrument purporting to assign “[t]he entire right, title and interest in” all “Patents granted” on the application that issued as the ’130 patent. Ex. 2004, 1. The assignee named in that assignment is “ESIP, LLC, Series No. 2,” which Patent Owner consistently refers to as “ESIP Series 2, LLC.” Id.; Prelim. Resp. 1; PO Resp. 1. We assume, without deciding, that Patent Owner’s nomenclature is correct.

*C. The Asserted Grounds of Unpatentability*

Petitioner contends that claims 1, 3, and 17 of the '130 patent are unpatentable based on the following grounds (Pet. 17–60):<sup>2</sup>

<b>Statutory Ground</b>	<b>Basis</b>	<b>Challenged Claims</b>
§ 103	Sevy <sup>3</sup> and Cronenberg <sup>4</sup>	1, 3, and 17
§ 103	Sevy and Giroux <sup>5</sup>	1, 3, and 17
§ 103	Sevy and Kato <sup>6</sup>	1, 3, and 17
§ 103	Sevy and Stroia <sup>7</sup>	1, 3, and 17

*D. The '130 Patent*

The '130 patent, titled “Industrial, Germicidal, Diffuser Apparatus and Method,” issued on August 16, 2016. Ex. 1001, at [45], [54]. The '130 patent relates to “[a] modular, integrated, combination air purification and aroma diffuser” that makes use of “a micro-cyclone for quiet, well diffused flow of ultra-fine droplets.” Ex. 1001, at [57].

The diffusion of “[o]verly large particles” poses “a number of problems,” including wasting the aromatic product and causing the particles to settle out of the air too quickly. *Id.* at 4:15–28. To avoid these

---

<sup>2</sup> Petitioner also relies on a declaration from Fred P. Smith, P.E., CSP. Ex. 1007.

<sup>3</sup> Sevy, U.S. Patent No. 7,878,418 B2, issued Feb. 1, 2011 (Ex. 1003, “Sevy”).

<sup>4</sup> Cronenberg, U.S. Patent No. 4,243,396, issued Jan. 6, 1981 (Ex. 1004, “Cronenberg”).

<sup>5</sup> Giroux, U.S. Patent No. 8,001,963 B2, issued Aug. 23, 2011 (Ex. 1005, “Giroux”).

<sup>6</sup> Kato et al., U.S. Patent No. 6,236,042 B1, issued May 22, 2001 (Ex. 1006, “Kato”).

<sup>7</sup> Stroia et al., U.S. Patent No. 6,029,913, issued Feb. 29, 2000 (Ex. 1009, “Stroia”).

problems, the '130 patent describes using a “micro-cyclone” to separate “the comparatively larger particles from the flow” of air containing atomized droplets of the liquid product to be diffused. *Id.* at 4:3–14. This micro-cyclone “contains a spiral channel” that “begins below a central plane” that is “defined by a plate.” *Id.* at 16:65–17:4. The channel spirals along a “circular route . . . from below the plate” to above it. *Id.* at 17:18–20. In use, this micro-cyclone causes “the comparatively larger particles in the stream of air . . . to smash and coalesce against the inside of the outer wall of the channel,” leaving only “the comparatively smallest range of droplets [to be] passed out to the nozzle.” *Id.* at 17:26–31. After coalescing, the larger droplets “drip back into the atomizer . . . to be re-atomized.” *Id.* at 17:28–29.

*E. Illustrative Claim*

Claims 1 and 17 of the '130 patent are independent, and claim 1 is illustrative; it recites:

1. A method for introducing a scent into breathable air, the method comprising:
  - providing a system comprising a reservoir, eductor, and separator operably connected to one another;
  - providing a liquid constituting an aromatic substance selected by an operator for the scent to be introduced into the breathable air;
  - drawing a first portion of the liquid from the reservoir by the eductor passing a flow of air;
  - entraining the first portion of the liquid into the flow;

forming droplets of the first portion by at least one of restricting an area through which the flow passes and the entraining;

separating out a second distribution of the droplets by passing the flow through a wall between a first chamber and a second chamber, the flow path spiraling axially and circumferentially, simultaneously and continuously, through an arcuate channel formed through the wall; and

passing a first distribution of the droplets out of the separator into the breathable air.

Ex. 1001, 23:22–41.

## ANALYSIS

### *A. Real Parties in Interest*

A petition for *inter partes* review “may be considered only if . . . the petition identifies all real parties in interest.” 35 U.S.C. § 312(a)(2). Here, the Petition identifies Petitioner and Puzhen, LLC as real parties in interest (“RPIs”). Pet. 3. Patent Owner argues that this identification is incomplete and that both Puzhen Life Co., Ltd. (“Puzhen Life HK”) and doTERRA International, LLC (“doTERRA”) should have been identified as RPIs as well. PO Resp. 1–6.

#### *1. Legal Principles*

Petitioner bears the overall burden to prove that all real parties in interest have been identified. *Worlds Inc. v. Bungie, Inc.*, 903 F.3d 1237, 1242 (Fed. Cir. 2018) (applying this rule in the context of 35 U.S.C. § 315(b)). Thus, we evaluate the evidence adduced at trial to determine whether Petitioner has

borne its burden. In doing so, although there are many ways in which a non-party can become a real party in interest, we need only focus on the arguments raised by Patent Owner. *Id.* (“an IPR petitioner’s initial identification of the real parties in interest should be accepted unless and until disputed by a patent owner” by “produc[ing] some evidence to support its argument that a particular third party should be named a real party in interest”); *Wi-Fi One, LLC v. Broadcom Corp.*, 887 F.3d 1329, 1338 n.3 (Fed. Cir. 2018) (“the Board properly focused on the factors [the patent owner] raised in its argument”).

“[A]t a general level, the ‘real party-in-interest’ is the party that desires review of the patent.” Office Patent Trial Practice Guide, 77 Fed. Reg. 48,756, 48,759 (Aug. 14, 2012) (“Trial Practice Guide”). “Whether a party who is not a named participant in a given proceeding nonetheless constitutes a ‘real party-in-interest’ . . . to that proceeding is a highly fact-dependent question” with no “bright line test,” and is assessed “on a case- by-case basis.” Trial Practice Guide, 77 Fed. Reg. at 48,759 (citing *Taylor v. Sturgell*, 553 U.S. 880, 893–95 (2008)). “Determining whether a non- party is a ‘real party in interest’ demands a flexible approach that takes into account both equitable and practical considerations, with an eye toward determining whether the non-party is a clear beneficiary that has a preexisting, established relationship with the petitioner.” *Applications in Internet Time, LLC v. RPX Corp.*, 897 F.3d 1336, 1351 (Fed. Cir. 2018). Not just any relationship will be sufficient. Instead, Congress intended the term “real party in interest” to have its “common-law meaning,” *id.*, and, “when it comes to evaluating the relationship

between a party bringing a suit and a non-party, the common law seeks to ascertain who, from a ‘practical and equitable’ standpoint, will benefit from the redress that the chosen tribunal might provide.” *Applications*, 897 F.3d at 1349 (quoting Trial Practice Guide, 77 Fed. Reg. at 48,759).

## 2. *Application to Puzhen Life HK*

Patent Owner argues that Puzhen Life HK should have been named as “a real party-in-interest because [it] is a parent company controlling [Petitioner] and owning the substantive, U.S. intellectual property rights.” PO Resp. 2.<sup>8</sup> The record developed at trial establishes the following facts. Puzhen Life HK is a Chinese company with two directors, Song BaoJie and Li DongSheng. Ex. 2005, 2, 5, 9. Petitioner is a New York limited liability company. Ex. 2006, 7. From its founding on March 24, 2011, until 2013, Petitioner’s sole member was Song BaoJie, one of the directors of Puzhen Life HK. Ex. 2009, 15 (Response to Interrogatory No. 10). Since then, Petitioner’s sole member has been Li DongSheng. *Id.* A website exists for Puzhen in general. Ex. 2008. That website was registered by a third entity altogether, Puzhen Life LLC. Ex. 2007. The contact information on the

---

<sup>8</sup> Patent Owner’s only argument on the trial record is contained in the Patent Owner Response. The Preliminary Response forms no part of the record of the trial in this proceeding. Paper 11, 3 (“any arguments . . . not raised in the response will be waived,” with no exclusion from this rule for arguments raised in the preliminary response); see *Cook Group Inc. v. Boston Sci. Scimed, Inc.*, Case IPR2017-00135, slip op. at 49 (PTAB Nov. 15, 2018) (Paper 82) (“we generally do not allow Patent Owner to carry over arguments from the Preliminary Response”). In any case, the argument Patent Owner presented in the Preliminary Response was identical to the argument it presented during trial. Compare Paper 5, 3, with PO Resp. 2.

website lists Petitioner and Puzhen Life HK as the United States and Hong Kong offices, respectively, of Puzhen generally. Ex. 2008, 2. A power of attorney for Petitioner in this proceeding was signed by Bao Jie Song, who is a director of Puzhen Life HK and who identifies herself on the power of attorney as the chief executive officer of Petitioner. Paper 8. Petitioner is not the assignee of any United States patents or trademarks, but Puzhen Life HK is. Ex. 2010; Ex. 2011. Finally, during an appeal to the Federal Circuit, Petitioner filed a Certificate of Interest identifying Puzhen Life HK among its “[p]arent corporations and publicly held companies that own 10% or more of stock in the party.” Ex. 2022.

As Patent Owner argues, these facts at most establish that Puzhen Life HK is a parent company of Petitioner. Some of the individual facts, however, are not consistent with a finding that Puzhen Life HK is the parent company of Petitioner. For example, Puzhen’s website appears to identify Petitioner and Puzhen Life HK as sister companies operating in different countries. Ex. 2008, 2. And the sole owners—referred to as members in the context of a limited liability company—of Petitioner are and always have been individual people, not Puzhen Life HK. Ex. 2009, 16. Nevertheless, given the other established facts, particularly Petitioner’s identification of Puzhen Life HK as a parent company of Petitioner in the Federal Circuit Certificate of Interest, we find that the evidence as a whole establishes that Puzhen Life HK is a parent company of Petitioner. Ex. 2022.

Without more, we generally have not treated a non-party who is the parent company of the petitioner as a real party in interest who must be



named under 35 U.S.C. § 312(a)(2). *Par Pharm., Inc. v. Jazz Pharms., Inc.*, Case IPR2015-00546, slip op. at 13–19 (PTAB July 28, 2015) (Paper 25). We do not interpret *Applications* as having changed this rule such that all parent companies of petitioners for *inter partes* reviews are *per se* RPIs. First, the traditional rule is that mere status as a corporate parent is insufficient to render an entity a real party in interest (or even as falling within the broader category of a privy), and *Applications* preserved the common-law meaning of “real party in interest.” 897 F.3d at 1351; *see* IPR2017-02197 *Taylor v. Sturgell*, 553 U.S. 880, 893–95 (2008) (summarizing the common-law rule as recognizing six types of relationships that constitute privity, but not including a parent-child corporate relationship among them); Trial Practice Guide, 77 Fed. Reg. at 48,759 (even some parties qualifying as privies do not need to be identified as real parties in interest). Second, *Applications* did not involve a corporate parent who was unnamed as an RPI. 897 F.3d at 1339 (describing the unnamed, alleged RPI as “one of [the petitioner’s] clients”). Thus, we are not persuaded that Puzhen Life HK’s status as the parent company of Petitioner, by itself, is sufficient to render Puzhen Life HK an RPI in this proceeding. Something more is required.

Under *Applications*, relevant factors for determining whether a non-party is an RPI include the non-party’s relationship with the petitioner, the non-party’s relationship to the petition, and the nature of the entity filing the petition. 897 F.3d at 1351. Here, none of these factors suggests that Puzhen Life HK is a “clear beneficiary” with a

sufficient “preexisting, established relationship with the petitioner.” *Id.*

As discussed above, the relationship between Puzhen Life HK and Petitioner is that of parent and subsidiary companies. Although it could be argued that the parent company of the petitioner always “has a preexisting, established relationship with the petitioner” and is likely to benefit when and to the degree that its subsidiary benefits, the preservation of the common-law meaning of RPI in *Applications* suggests that the mere establishment of parent-company status is insufficient to render a non-party an RPI. As the Federal Circuit has held in the context of privity, “control of a party . . . through stock ownership or corporate officership is not enough to create privity, absent a showing that the corporate form has been ignored.” *Gillig v. Nike, Inc.*, 602 F.3d 1354, 1362 (Fed. Cir. 2010). We see no reason why this rationale does not apply equally to the determination of whether a relationship is sufficient to give rise to an RPI. As there is no evidence before us that Petitioner and Puzhen Life HK have ignored the corporate form, we do not conclude that the mere parent-subsidiary relationship alleged here is sufficient to make Puzhen Life HK an RPI.

We have been directed to no evidence of record relating to Puzhen Life HK’s relationship to the present Petition. PO Resp. 2–5. Accordingly, there is no evidence that Puzhen Life HK directed or assisted in the preparation and filing of the Petition.<sup>9</sup> Absent

---

<sup>9</sup> Patent Owner did not seek any additional discovery into the question of what role, if any, Puzhen Life HK may have played in preparing or filing the Petition.

such evidence, we do not presume that Puzhen Life HK's status as a parent of Petitioner means that Puzhen Life HK was involved in preparing or filing the Petition.

Finally, we note that this is not a case in which, even if it had been established that Puzhen Life HK sought to use Petitioner as a proxy to file and litigate what should be Puzhen Life HK's Petition, Puzhen Life HK has achieved any clear benefit it would not have achieved by filing and litigating the Petition itself. In some cases, the non-party is barred by 35 U.S.C. § 315(b) from filing a Petition for *inter partes* review because it has waited too long after being served with an infringement complaint, and the non-party seeks to file a petition through a proxy. This is not one of those cases. Puzhen Life HK has never been accused of infringing the challenged patent, but Petitioner has. Ex. 1030, 23 (identifying doTERRA, Petitioner, and Puzhen, LLC as "Defendants"), 33–34 (accusing only "Defendants" of infringing the '130 patent). On this record, it does not appear that Puzhen Life HK would have had anything to gain by hiding behind Petitioner as a proxy.

Because the relationships Puzhen Life HK has to Petitioner, to the Petition, and to this proceeding are not sufficiently close, and because the benefits of this proceeding to Puzhen Life HK are not sufficiently great, we conclude that the record supports a conclusion that Petitioner's RPI identification is not incomplete for failure to identify Puzhen Life HK.

### 3. *Application to doTERRA*

Patent Owner argues that doTERRA should have been named as a real party in interest because it has "agree[d] to be bound by the determination of issues

in an action between others.” PO Resp. 5. Specifically, Patent Owner argues that doTERRA and Petitioner “are co-defendants in an underlying, related [piece of] litigation,” in which doTERRA has “stipulated to the same estoppel applicable to Petitioner [arising] from this proceeding.” *Id.* at 6. Patent Owner also notes that, at the time the present Petition was filed, only doTERRA, not Petitioner, was accused of infringing the ’130 patent. *Id.*

Patent Owner cites *Taylor* as supporting a conclusion that doTERRA’s agreement to be bound by the estoppel arising from the present proceeding renders it a real party in interest. *Id.* at 5 (citing *Taylor*, 128 S. Ct. at 2164). But the rule established in *Taylor* is not that anyone who agrees to be bound by the determination of issues in an action between others is an RPI. Instead, the rule is that “[a] person who agrees to be bound by the determination of issues in an action between others is bound in accordance with the terms of his agreement.” *Taylor*, 553 U.S. at 893 (quoting 1 Restatement (Second) of Judgments § 40, p. 390 (1980)). Here, under the agreement in question, doTERRA stated that it was “willing to be bound by the same estoppel that would apply [to] Puzhen based on the final result (after all appeals) of the [present] IPR.” PO Resp. 6 (quoting Ex. 2013, 7). Under *Taylor*, doTERRA is bound by the terms of this agreement, meaning that it is bound by any estoppel applicable to Petitioner, and a later tribunal may preclude doTERRA from pursuing similar challenges in a subsequent proceeding. The terms of the agreement, however, do not apply to the present proceeding, because no estoppel has yet attached to Petitioner (and none will until the entry of this Decision). *See* 35 U.S.C. § 315(e).

Under *Applications*, relevant factors for determining whether a non-party is an RPI include the non-party's relationship with the petitioner, the non-party's relationship to the petition, and the nature of the entity filing the petition. 897 F.3d at 1351. Here, none of these factors suggests that doTERRA is a "clear beneficiary" with a sufficient "preexisting, established relationship with the petitioner." *Id.*

According to Patent Owner, the relationship between doTERRA and Petitioner is that of customer and supplier. Ex. 1030, 27. A standard customer-supplier relationship does not render the absent member of the relationship an RPI. *WesternGeco LLC v. ION Geophysical Corp.*, 889 F.3d 1308, 1321 (Fed. Cir. 2018) ("ION and PGS had a contractual and fairly standard customer-manufacturer relationship regarding the accused product," which "does not necessarily suggest that the relationship is sufficiently close . . . that the parties were litigating . . . the IPRs as proxies for the other."). Thus, the customer-supplier relationship between doTERRA and Petitioner does not render doTERRA an RPI.

The case is similar with respect to the relationship of doTERRA and Petitioner as co-defendants in an infringement lawsuit. Without more, mere status as a co-defendant is insufficient to render a non-party an RPI *per se*. *Panties Plus, Inc. v. Bragel Int'l, Inc.*, Case IPR2017-00044, slip op. at 7 (PTAB Apr. 12, 2017) (Paper 6).

We have been directed to no evidence of record relating to doTERRA's relationship to the present Petition. PO Resp. 5–6. Accordingly, there is no evidence that doTERRA directed or assisted in the

preparation and filing of the Petition.<sup>10</sup> Absent such evidence, we do not presume that doTERRA's status as a co-defendant in the related infringement lawsuit means that doTERRA was involved in preparing or filing the Petition.

Finally, as was the case with Puzhen Life HK, there is no evidence that doTERRA has achieved any clear benefit from Petitioner filing the Petition that doTERRA would not have achieved by filing and litigating the Petition itself. The complaint asserting infringement of the '130 patent was dated September 29, 2016, so it could have been served no earlier than that date. Ex. 1030, 37. The Petition in the present proceeding was filed September 28, 2017, which was less than one year later, at which time no party served with the infringement complaint would have been barred by § 315(b). Pet. 61. Additionally, doTERRA has agreed to be bound by whatever estoppel arises against Petitioner from this proceeding, so, to the extent that doTERRA sought to use Petitioner as a proxy, doTERRA did not avoid becoming subject to the consequences of this proceeding. Ex. 2013, 7.

Because the relationships doTERRA has to Petitioner, to the Petition, and to this proceeding are not sufficiently close, and because the benefits of this proceeding to doTERRA are not sufficiently great, we conclude that the record supports a conclusion

---

<sup>10</sup> Patent Owner did not seek any additional discovery into the question of what role, if any, doTERRA may have played in preparing or filing the Petition

that Petitioner’s RPI identification is not incomplete for failure to identify doTERRA.<sup>11</sup>

*B. Claim Construction*

In an *inter partes* review, we construe claim terms in an unexpired patent according to their broadest reasonable construction in light of the specification of the patent in which they appear.<sup>12</sup> 37 C.F.R. § 42.100(b) (2016). Claim terms generally are given their ordinary and customary meaning, as would be understood by one of ordinary skill in the art in the context of the entire disclosure. *In re Translogic Tech., Inc.*, 504 F.3d 1249, 1257 (Fed. Cir. 2007).

Petitioner proposes construing two terms: “wall” and “included circumferential angle.” Pet. 10–11. Patent Owner disagrees with Petitioner’s proposed construction of “wall” but does not dispute the construction of “included circumferential angle.” PO Resp. 14–16.

---

<sup>11</sup> Because there is no allegation of a time bar under 35 U.S.C. § 315(b), it may be that Petitioner would be permitted to correct its Petition to remedy any incomplete identification of RPIs under 35 U.S.C. § 312(a)(2). See *Lumentum Holdings, Inc. v. Capella Photonics, Inc.*, Case IPR2015-00739, slip op. at 3–6 (PTAB Mar. 4, 2016) (Paper 38) (precedential) (holding that “§ 312(a) is not jurisdictional” and that a petitioner therefore may have an opportunity to correct a failure to comply with § 312(a)(2)). Because we decide that Petitioner’s RPI identification is not incomplete for failure to identify either Puzhen Life HK or doTERRA as an RPI, however, we need not reach the question of whether such correction is permitted here.

<sup>12</sup> A recent amendment to this rule does not apply here, because the Petition was filed before November 13, 2018. See “Changes to the Claim Construction Standard for Interpreting Claims in Trial Proceedings Before the Patent Trial and Appeal Board,” 83 Fed. Reg. 51,340 (Oct. 11, 2018) (to be codified at 37 C.F.R. pt. 42).

### 1. “Wall”

The term “wall” appears in all three challenged claims. Specifically, claims 1 and 3 require “separating out a second distribution of the droplets by passing the flow through a wall between a first chamber and a second chamber, the flow path spiraling axially and circumferentially, simultaneously and continuously, through an arcuate channel formed through the wall,” and claim 17 requires “providing a separator” by “creating a flow path for the flow spiraling axially while passing in a circumferential direction at a substantially constant radius around an included angle through a wall traversed by a spiral channel.” Ex. 1001, 23:22–41, 23:44–45, 24:39–64. Petitioner argues that “wall” should be interpreted as “a barrier substantially separating two spaces.” Pet. 10–11. Patent Owner argues instead that “wall” should be interpreted as “‘wall,’ or perhaps ‘wall or plate.’” PO Resp. 14–16.

Both parties agree that the term “wall” includes the structure described in the Specification of the ’130 patent as flange, plate, or plane 96 of Figure 12. Pet. 11; PO Resp. 14–15. The difference in the parties’ positions relates to how far beyond the structure of Figure 12 the term “wall” may reach. Patent Owner argues that “wall” should be limited to “a structure equivalent to the plate 96 described in the Specification.” PO Resp. 15. There are two problems with this argument. First, it asks us to import limitations from the Specification of the ’130 patent. Although “understanding the claim language may be aided by explanations contained in the written description, it is important not to import into a claim limitations that are not a part of the claim,” so we decline the invitation to do so here.



*Superguide Corp. v. DirecTV Enterprises, Inc.*, 358 F.3d 870, 875 (Fed. Cir. 2004). In addition, even if it were proper to import limitations from the Specification, it would not be appropriate to limit the claim term “wall” to a “plate” on the basis of the description of plate 96 in Figure 12 and the accompanying portion of the Specification of the ’130 patent, because the Specification does not describe structure 96 solely as a “plate.” Instead, the Specification describes this structure sometimes as a “plate,” sometimes as a “plane,” and sometimes as a “flange.” Ex. 1001, 16:65– 17:17, 18:13–21. Accordingly, if a “wall” is “a structure equivalent to the plate 96,” as Patent Owner argues it is, “wall” must be interpreted at least broadly enough to encompass a “plane” or a “flange” in addition to a “plate.”

Patent Owner also argues that a wall cannot be Petitioner’s proposed “barrier substantially separating two spaces,” because claim 1 requires the wall to be “between a first chamber and a second chamber.” PO Resp. 15. Patent Owner is correct that, in claim 1, the wall must be located between two chambers, rather than two spaces. Ex. 1001, 23:22–41. Independent claim 17, on the other hand, does not specify what type of spaces the wall separates. *Id.* at 24:39–64. Accordingly, to the extent that “chamber” is narrower than “space,” construing “wall” as incorporating all the limitations of claim 1 would result in an impermissibly narrow interpretation of the scope of claim 17. Instead, the proper approach is to acknowledge that, as Petitioner argues, a wall may separate any two spaces, but that claim 1 is not satisfied unless those two spaces are both chambers.

Patent Owner also argues that a wall cannot “substantially separate two spaces in just any manner,” because claim 17 requires “a wall traversed by a spiral channel.” PO Resp. 15–16. Patent Owner is correct that claim 17 recites “a wall traversed by a spiral channel.” Ex. 1001, 24:39–64. Claim 1, on the other hand, requires “an arcuate channel formed through the wall.” *Id.* at 23:22–41. To the extent there is any difference between the “spiral channel” of claim 17 and the “arcuate channel” of claim 1, it would be error to limit a wall to only structures that contain one or the other type of channel. The better course is to treat a wall as a barrier that can be traversed by a channel, with claim 1 satisfied only if there is an arcuate channel traversing the wall and claim 17 satisfied only if there is a spiral channel traversing the wall.

Petitioner’s proposed construction is supported by the language of the claims and written description of the ’130 patent. Whatever form the structure labeled 96 in Figure 12 takes (flange, plate, or plane), the purpose of that structure is to define a space below and a separate space above, with the flow passing from one space to the other via a channel passing through the structure. Ex. 1001, 17:15–20 (discussing flow passing “from below the plate 96 to above the plate 96”), Fig. 12. Claim 1 makes this purpose clear, specifying that the wall separates “a first chamber and a second chamber.” *Id.* at 23:22–41. For these reasons, we adopt the construction of “wall” proposed by Petitioner, and we interpret “wall” as “a barrier substantially separating two spaces.”

## 2. “Included Circumferential Angle”

The term “included circumferential angle” appears in the challenged claims only in claim 3. Specifically, claim 3 recites a limitation requiring that “the included circumferential angle [be] from 90 degrees to 360 degrees.” Ex. 1001, 23:44–45. Petitioner argues that we should construe “included circumferential angle” as “a measure of degree of revolution around a longitudinal axis from the beginning to the end of the channel disclosed in claim 1.” Pet. 10. Patent Owner makes no argument regarding how to construe this term. PO Resp. 14–16. The parties do not disagree about the scope of claim 3 with respect to the term “included circumferential angle.” Accordingly, we conclude that this term does not require express construction. *See Vivid Techs., Inc. v. Am. Sci. & Eng’g, Inc.*, 200 F.3d 795, 803 (Fed. Cir. 1999) (“only those terms need be construed that are in controversy, and only to the extent necessary to resolve the controversy”).

### C. *Obviousness over Sevy and Cronenberg*

Petitioner argues that the subject matter of claims 1, 3, and 17 would have been obvious to a person of ordinary skill in the art given the teachings of Sevy and Cronenberg. Pet. 17–35.

#### 1. *Sevy*

Sevy “relates to . . . novel systems and methods for integrating air supplies, reservoirs and atomizers into an integrated system.” Ex. 1003, 1:6–8. According to Sevy, “it would be an advance in the art to provide an atomizer that provides a better atomization or a smaller mean or average size of droplet in the distribution of atomized droplets

compared with prior art devices capable of atomizing.” *Id.* at 1:66–2:3. Sevy discloses accomplishing this by “rel[ying] on direction change and momentum of impact to further comminute the droplets into a more finely atomized mist, while separating out comparatively larger droplets in a comparatively very short distance.” *Id.* at 2:13–19. In particular, Sevy discloses that large droplets “cannot move with the air flow, typically because they . . . will not be able to quickly turn to follow the flow of air,” causing them to “strike the walls of the opening.” *Id.* at 8:64–9:4. Sevy’s disclosed separator is part of a larger system that is illustrated in Figure 7, reproduced below:

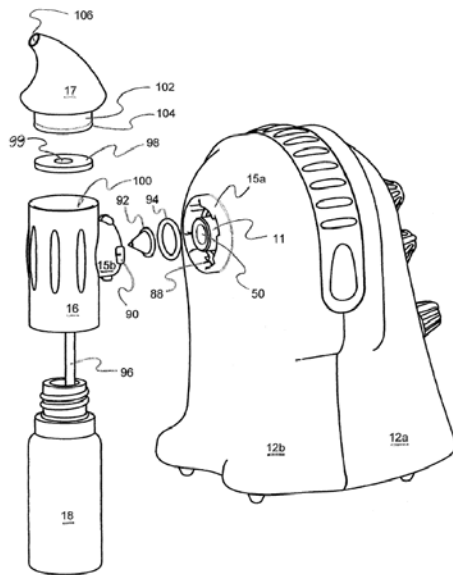

FIG-7

Figure 7 of Sevy depicts “a partially-exploded perspective view of the atomizer portion of [Sevy’s] apparatus.” *Id.* at 4:60–62. In Figure 7, air passed through nozzle 92 creates a vacuum at siphon 96,

causing liquid to be drawn from reservoir 18. *Id.* at 8:28–44. This liquid “is partially atomized by the flow of air through the nozzle.” *Id.* Figure 7 also illustrates a separator that “is formed by the main walls of” atomizer 16 and separator plate 98, containing aperture 99. *Id.* at 8:55–63. The flow of air from the atomizer passes through aperture 99. *Id.* at 8:64–65. Large droplets “cannot move with the air flow” and “will not be able to quickly turn to follow the flow of air,” causing them to “strike the walls of the opening . . . or the separator plate.” *Id.* at 8:65–9:4. The remaining smaller droplets of liquid pass into the environment through distributor 17, while the large droplets of liquid removed by the separator agglomerate and “drip back into” the reservoir. *Id.* at 9:5–43.

## 2. Cronenberg

Cronenberg relates to “[a] separator adapted for use as part of a fluid dispenser system for supplying inhalable fluids.” Ex. 1004, at [57]. “The separator is adapted to be positioned within the fluid dispenser system so that the mixture of liquid and gas passes along [a] tortuous passageway,” causing “the larger droplets of liquid [to be] removed from the mixture.” *Id.* at 2:48–55. This allows the separator “to achieve the desired vapor and avoid the presence of liquid droplets in the gas and liquid mixture.” *Id.* at 1:20–22. Cronenberg’s “tortuous passageway” is illustrated in Figure 3, reproduced below:

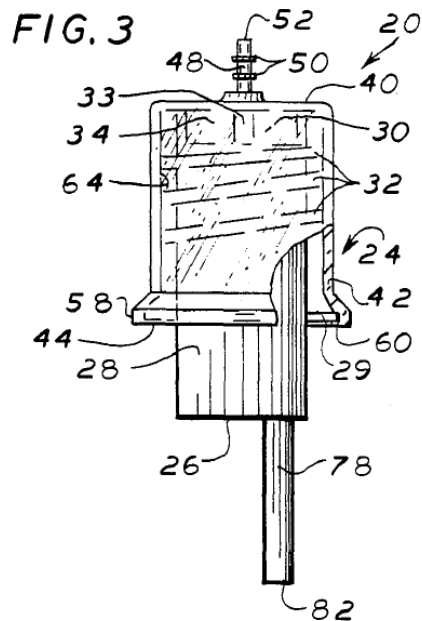

Figure 3 depicts the separator and nozzle disclosed by Cronenberg. *Id.* at 2:63–67. The separator includes an inner member with side wall 28 and outer casing 24. *Id.* at 3:7–13. Extending along the side wall is continuous helix 32, which extends radially outward from the side wall. *Id.* at 3:12–14. The outer diameter of helix 32 is chosen to fit “in snug engagement with the inner surface” of outer casing 24. *Id.* at 4:7–10.

### 3. Analysis

Petitioner argues that all limitations of claims 1, 3, and 17 are taught or suggested by the combination of Sevy and Cronenberg. Pet. 17–35. Patent Owner argues that neither Sevy nor Cronenberg teaches or suggests the “flow path . . . through a wall” of claim 17 or the “arcuate channel formed through [a] wall” of claim 1. PO Resp. 16–19. Patent Owner also

argues that a person of ordinary skill in the art would have had no reason to combine the teachings of Sevy with the teachings of Cronenberg and that a person of ordinary skill in the art would not have had a reasonable expectation of success in combining those teachings. *Id.* at 19–21, 26–27. Finally, Patent Owner argues that the Office has granted patents containing claims similar to but broader than the claims challenged here, despite the Office having been made aware of the existence of both Sevy and Cronenberg. *Id.* at 22–26.

a. Claim 1

As Petitioner argues, Pet. 22–27, claim 1 recites a preamble and seven limitations: “[a] method for introducing a scent into breathable air,” “providing a system comprising a reservoir, eductor, and separator operably connected to one another,” “providing a liquid constituting an aromatic substance selected by an operator for the scent to be introduced into the breathable air,” “drawing a first portion of the liquid from the reservoir by the eductor passing a flow of air,” “entraining the first portion of the liquid into the flow,” “forming droplets of the first portion by at least one of restricting an area through which the flow passes and the entraining,” “separating out a second distribution of the droplets by passing the flow through a wall between a first chamber and a second chamber, the flow path spiraling axially and circumferentially, simultaneously and continuously, through an arcuate channel formed through the wall,” and “passing a first distribution of the droplets out of the separator into the breathable air.” Ex. 1001, 23:22–41.

(1) *Preamble*

Petitioner argues that Sevy teaches the preamble of claim 1, a “method for introducing a scent into breathable air.” Pet. 22–23. Patent Owner does not dispute Petitioner’s argument or evidence. PO Resp. 16–27. Petitioner is correct. Sevy teaches essential oils having scents. Ex. 1003, 3:30–34. Moreover, Sevy teaches entraining these essential oils into breathing air. *Id.* at 1:12–16. Accordingly, Petitioner has shown by a preponderance of the evidence that the combination of Sevy and Cronenberg teaches the preamble of claim 1.

(2) *“Providing a system comprising a reservoir, eductor, and separator operably connected to one another”*

Petitioner argues that Sevy teaches a system comprising an operably connected reservoir, educator, and separator. Pet. 23. Patent Owner does not dispute Petitioner’s argument or evidence. PO Resp. 16–27. Petitioner is correct. Sevy teaches drawing liquid from a reservoir using a vacuum created by an eductor, with a separator connected downstream of the eductor. Ex. 1003, 8:40–59, Figs. 7, 9. Accordingly, Petitioner has shown by a preponderance of the evidence that the combination of Sevy and Cronenberg teaches this limitation of claim 1.

(3) *“Providing a liquid constituting an aromatic substance selected by an operator for the scent to be introduced into the breathable air”*

Petitioner argues that Sevy teaches providing an aromatic liquid substance selected for the scent it can introduce into the air. Pet. 23. Patent Owner



does not dispute Petitioner's argument or evidence. PO Resp. 16–27. Petitioner is correct. Sevy teaches “a bottle containing a liquid comprising a scent, such as an essential oil may be selected from a vendor and used directly by connection to the atomizer.” Ex. 1003, 3:30–33. Accordingly, Petitioner has shown by a preponderance of the evidence that the combination of Sevy and Cronenberg teaches this limitation of claim 1.

(4) *“Drawing a first portion of the liquid from the reservoir by the eductor passing a flow of air”*

Petitioner argues that Sevy teaches drawing liquid from the reservoir by passing air through the eductor. Pet. 24. Patent Owner does not dispute Petitioner's argument or evidence. PO Resp. 16–27. Petitioner is correct. Sevy teaches that “[e]duction by the stream of air through the nozzle 92 draws a vacuum (e.g., reduced pressure) on the siphon 96, drawing liquid from the reservoir 18.” Ex. 1003, 8:40–44. Accordingly, Petitioner has shown by a preponderance of the evidence that the combination of Sevy and Cronenberg teaches this limitation of claim 1.

(5) *“Entraining the first portion of the liquid into the flow”*

Petitioner argues that Sevy teaches entraining the liquid drawn from the reservoir into the flow of air. Pet. 24. Patent Owner does not dispute Petitioner's argument or evidence. PO Resp. 16–27. Petitioner is correct. Sevy teaches that “[t]he liquid from the reservoir is partially atomized by the flow of air through the nozzle 92 as it educts the liquid.” Ex. 1003, 8:40–44. Moreover, Sevy teaches entraining the liquid from its reservoir into

breathing air. *Id.* at 1:12–16. Accordingly, Petitioner has shown by a preponderance of the evidence that the combination of Sevy and Cronenberg teaches this limitation of claim 1.

(6) *“Forming droplets of the first portion by at least one of restricting an area through which the flow passes and the entraining”*

Petitioner argues that Sevy teaches forming droplets of the liquid it draws from its reservoir by entraining the liquid in the flow of air. Pet. 24. Patent Owner does not dispute Petitioner’s argument or evidence. PO Resp. 16–27. Petitioner is correct. As discussed above, Sevy teaches that “[t]he liquid from the reservoir is partially atomized by the flow of air through the nozzle 92 as it educts the liquid.” Ex. 1003, 8:40–44. Moreover, Sevy teaches forming droplets of the liquid. *Id.* at 8:45–54. Accordingly, Petitioner has shown by a preponderance of the evidence that the combination of Sevy and Cronenberg teaches this limitation of claim 1.

(7) *“Separating out a second distribution of the droplets by passing the flow through a wall between a first chamber and a second chamber, the flow path spiraling axially and circumferentially, simultaneously and continuously, through an arcuate channel formed through the wall”*

Petitioner argues that the combination of Sevy and Cronenberg teaches this limitation of claim 1. Pet. 24–27. Patent Owner argues that neither reference individually teaches or suggests this limitation, because neither reference teaches or

suggests the recited “arcuate channel formed through the wall.” PO Resp. 16–19. Patent Owner also argues that a person of ordinary skill in the art would not have had a reason to combine the teachings of Sevy with those of Cronenberg to arrive at this limitation of claim 1. *Id.* at 19–21, 26–27.

There is evidence to support Petitioner’s argument. First, Sevy teaches separating some droplets from the mixed droplet-air flow by passing the flow through an orifice in a wall between a first chamber and a second chamber. Ex. 1003, 8:64–9:2 (“[T]he separator plate 98 passes the flow of air from the atomizer 16 through apertures 99 therein. Droplets that . . . have too large a size and mass will not be able to quickly turn to follow the flow of air.”). Second, Cronenberg teaches forcing a mixture of air and water droplets through a helical channel “to cause centrifugal force to push . . . water droplets out of the mixture.” Ex. 1004, 5:37–43, Fig. 3. Cronenberg also teaches that “[o]ther types of radial surfaces can . . . be utilized, such as . . . arcuate passageways in place of the helix.” *Id.* at 3:12–21. Mr. Smith testifies that a person of ordinary skill in the art “would [have] replace[d] the aperture(s) in plate 98 with the helical pathway of Cronenberg.” Ex. 1007, 49–50. Where, as here, the prior art teaches two alternative methods for achieving the same result, it likely would have been obvious to substitute one for the other. *In re Fout*, 675 F.2d 297, 301 (CCPA 1982) (“Because both Pagliaro and Waterman teach a method for separating caffeine from oil, it would have been prima facie obvious to substitute one method for the other.”); see *KSR Int’l Co. v. Teleflex Inc.*, 550 U.S. 398, 417 (2007) (an invention is likely obvious if it is no “more than the

predictable use of prior art elements according to their established functions”). Thus, Petitioner has directed us to evidence showing that it would have been obvious to substitute an arcuate channel, as taught by Cronenberg, for the straight orifice in Sevy’s plate. When this substitution is made, the combination of Sevy and Cronenberg teaches using an arcuate passageway to separate liquid droplets from a mixed air-droplet flow as the flow moves from a chamber on one side of a wall to a chamber on the other side of the wall.

Patent Owner argues that, despite this evidence, Petitioner has not shown that claim 1 would have been obvious over the combination of Sevy and Cronenberg, because neither Sevy nor Cronenberg individually teaches or suggests “an arcuate channel formed through the wall.” PO Resp. 16–19. Patent Owner is correct that neither reference, considered by itself, teaches forming an arcuate channel through a wall for the purpose of separating liquid droplets out of a mixed air-droplet flow. Sevy’s separator passes its flow through a wall, but not using an arcuate passageway. Ex. 1003, 8:64– 9:2. Cronenberg teaches accomplishing the same type of separation using an arcuate passageway, but not one passing through a wall. Ex. 1004, 3:12–21, 5:37–43, Fig. 3. Instead, Cronenberg’s arcuate or helical passageway is placed between two structures, an inner member with side wall 28 and an outer casing 24. *Id.* at 3:7–13. But Petitioner does not argue that either Sevy or Cronenberg alone teaches or suggests an arcuate passageway through a wall. Pet. 24–27. Instead, Petitioner argues that a person of ordinary skill in the art would have combined the teachings of Sevy with the teachings of Cronenberg to arrive at

an arcuate passageway through a wall as a means of separating droplets from a mixed air-droplet flow. *Id.* As discussed above, there is evidence to support this argument.

Patent Owner counters that a person of ordinary skill in the art would not have combined the teachings of Sevy with those of Cronenberg. PO Resp. 19–21, 26–27. Patent Owner offers several arguments along these lines. First, Patent Owner argues that the combination of Sevy and Cronenberg “changes the principles under which Cronenberg was designed to operate,” meaning that the teachings of the references could be combined only through hindsight inspired by the ’130 patent itself. *Id.* at 19–20. Patent Owner is correct that a reference cannot form part of an obviousness combination when the combination “would require a substantial reconstruction and redesign of the elements shown in [the reference] as well as a change in the basic principles under which the [reference] was designed to operate.” *In re Ratti*, 270 F.2d 810, 813 (CCPA 1959). But Petitioner’s proposed combination of Sevy and Cronenberg is quite different from the problematic combination in *Ratti*. In that case, the proposed combination required a resilient seal when the reference in question taught a rigid seal. *Id.* There is nothing of the sort here. In the proposed combination of Sevy and Cronenberg, a person of ordinary skill in the art would have understood that Sevy’s separation could be accomplished using an arcuate passageway of the type taught in Cronenberg, but retaining the plate of Sevy by replacing Sevy’s orifice with the arcuate passageway. Pet. 26; Ex. 1007, 51 (depicting “the arcuate passageway” of Cronenberg placed to traverse a

plate such as the plate of Sevy). There is no evidence in the record developed at trial that suggests that, just as rigidity and resiliency were opposite principles in *Ratti*, separation by arcuate passageway through a wall and separation by orifice through a wall are opposites. Accordingly, we are not persuaded that Petitioner's proposed combination depends upon hindsight.

Patent Owner next argues that a person of ordinary skill in the art would not have replaced Sevy's orifice with an arcuate channel *à la* Cronenberg because doing so "would result in markedly different flow momentums with the associated structures." PO Resp. 20 (citing Ex. 2024 ¶¶ 111, 122). The evidence Patent Owner cites is the testimony of David A. Bell, Ph.D., P.E., who states that "[i]nserting the helix from Cronenberg into the aperture in Sevy would result in markedly different flow momentums with the associated structures," as well as that a person of ordinary skill in the art "would not have recognized that the spiral path in Cronenberg could be used with the aperture in Sevy." Ex. 2024 ¶¶ 111, 122. But Dr. Bell does not provide the factual basis for his testimony on flow momentum, nor does he explain the reasoning supporting his conclusions. Because Dr. Bell's testimony is conclusory and unsupported, it is unhelpful and unpersuasive. *Exmark Mfg. Co. v. Briggs & Stratton Power Prods. Grp., LLC*, 879 F.3d 1332, 1350 (Fed. Cir. 2018) (conclusory statements by expert in support of damages analysis cannot support a verdict); *Arendi S.A.R.L. v. Apple Inc.*, 832 F.3d 1355, 1366 (Fed. Cir. 2016) (conclusory statements by expert in support of obviousness analysis may not be relied upon). Moreover, even if

the testimony could support a finding that incorporating Cronenberg's concept of a helical or arcuate passageway for separation into Sevy's separation plate would change the flow through the plate, this would be evidence of nothing more than the changed geometry of the system, not necessarily evidence of the concept's unworkability. Thus, we are not persuaded by the testimony of Dr. Bell that a person of ordinary skill in the art would have avoided incorporating Cronenberg's concept of a helical or arcuate passageway for separation into Sevy's separation plate.

Patent Owner also argues that the "design and spacing" of Cronenberg "would not work for an essential oil aroma diffuser because . . . the small openings and flow in the same direction would likely cause all sizes of oil droplets to coalesce as they move in the same direction with the flow." PO Resp. 20–21. This argument is unpersuasive for two reasons. First, none of the challenged claims requires "an essential oil aroma diffuser." Claims 1 and 3 recite "a liquid constituting an aromatic substance," and claim 17 recites "a liquid," with an optional limitation that the liquid "constitutes an aromatic substance." Ex. 1001, 23:22–41, 24:39–64. These limitations do not limit the claims to use with oils, much less essential oils. Second, this argument ignores Petitioner's proposed combination, in which the concept of an arcuate passageway for separation is taken from Cronenberg and used to replace the straight orifice through a separation plate in Sevy. Pet. 26 ("In place of aperture 99 of Sevy, a [person of ordinary skill in the art] would find it obvious to substitute Cronenberg's arcuate channel to achieve a desired separation."). Nowhere in this proposed

combination does Petitioner argue in favor of incorporating the “design and spacing” of Cronenberg’s helical channel. Thus, we are not persuaded by this argument that Petitioner has failed to show that a person of ordinary skill in the art would have had a reason to combine the teachings of Sevy and Cronenberg.

Finally, Patent Owner argues that, because Giroux, Kato, and Stroia “do not teach separation techniques,” a person of ordinary skill in the art likely would have concluded that “an arcuate channel, or a spiral pathway, would not be a good choice when seeking to achieve separation.” PO Resp. 26–27. According to Patent Owner, this is because, in light of the lack of separation teachings in Giroux, Kato, and Stroia, using Cronenberg’s arcuate channel to perform separation would have meant “proceeding contrary to accepted wisdom.” *Id.* at 26 (citing *In re Hedges*, 783 F.2d 1038 (Fed. Cir. 1986)). We do not interpret *Hedges* as establishing a rule that, where much of the prior art is silent on a particular claimed technique, practicing that technique is “contrary to accepted wisdom.” Instead, in *Hedges*, where the claim at issue required a reaction to proceed at high temperatures, the prior art consistently “suggest[ed] that lower temperatures of reaction were preferable.” 783 F.2d at 1041. An equivalent situation here might be if Giroux, Kato, and Stroia all suggested that separation using a straight orifice through a plate was better in some important respect than separation using an arcuate pathway, but Patent Owner does not argue that this is the case. PO Resp. 26–27. Moreover, even if Giroux, Kato, and Stroia all taught a different separation method from



Cronenberg, we still would be faced with Cronenberg's own teaching that forcing a mixture of air and liquid droplets through a helical channel "cause[s] centrifugal force to push . . . water droplets out of the mixture." Ex. 1004, 5:37–43. Accordingly, we are not persuaded by this argument that Petitioner has failed to show that a person of ordinary skill in the art would have had a reason to combine the teachings of Sevy and Cronenberg.

For these reasons, we conclude that Petitioner has shown by a preponderance of the evidence that a person of ordinary skill in the art would have had reason to combine the teachings of Sevy with those of Cronenberg, and we conclude that Petitioner has shown by a preponderance of the evidence that the combination of Sevy and Cronenberg teaches this limitation of claim 1.

(8) *"Passing a first distribution of the droplets out of the separator into the breathable air"*

Petitioner argues that Sevy teaches passing the mixture of air and droplets that pass through its separator into breathable air. Pet. 27. Patent Owner does not dispute Petitioner's argument or evidence. PO Resp. 16–27. Petitioner is correct. Sevy teaches that its "flow of air passes through the aperture 122 of the separator plate," and it "carries with it only those droplets that are sufficiently small . . . that they will drift substantially indefinitely with ambient air movement as they evaporate." Ex. 1003, 10:65–11:4. Accordingly, Petitioner has shown by a preponderance of the evidence that the combination of Sevy and Cronenberg teaches this limitation of claim 1.

## b. Claim 3

Claim 3 depends from claim 1 and adds a limitation requiring that “the included circumferential angle [be] from 90 degrees to 360 degrees.” Ex. 1001, 23:44–45. Petitioner argues that Cronenberg teaches or suggests this limitation. Pet. 27–29. Patent Owner does not dispute Petitioner’s argument or evidence. PO Resp. 16–27. Petitioner is correct. Cronenberg teaches helical channels that turn through more than 360 degrees from their entrance to their exit, but there is evidence of record showing that the amount of rotation through which a helical channel turns is a result-effective variable. Ex. 1002, 217–18 (“the length of the arcuate channel and the size of the included angle are result effective variables”); Ex. 1004, Fig. 3. When a variable is recognized as result-effective, “the discovery of an optimum value of [the] variable . . . is normally obvious.” *In re Antonie*, 559 F.2d 618, 620 (CCPA 1977). Thus, Cronenberg at least suggests helical channels that turn through an angle from 90 degrees through 360 degrees. Moreover, in addition to teaching helical channels and depicting those channels with included circumferential angles greater than 360 degrees, Cronenberg teaches the use of “[o]ther types of radial surfaces,” including “arcuate passageways in place of the helix 32 to accomplish similar results.” Ex. 1004, 3:12–18. Mr. Smith testifies that a person of ordinary skill in the art would have understood that the term “arcuate” in Cronenberg referred to a curve “like a bow or arch, which would be less than 360 degrees.” Ex. 1007, 50. Dr. Bell agrees. Ex. 1028, 223:13–16. Accordingly, Petitioner has shown by a preponderance of the

evidence that the combination of Sevy and Cronenberg teaches the limitation of claim 3.

c. Claim 17

As Petitioner argues, Pet. 29–35, claim 17 recites a preamble (“a method”) and nine limitations: “providing a reservoir connection to draw a liquid from a reservoir,” “providing an eductor connected to draw the liquid from the reservoir and entrain the liquid as droplets into a flow of air,” “providing a separator downstream from the eductor to receive the flow and divide out the comparatively larger sizes of droplets from the comparatively smaller sizes thereof remaining in the flow,” “the providing a separator, further comprising creating a flow path for the flow spiraling axially while passing in a circumferential direction at a substantially constant radius around an included angle through a wall traversed by a spiral channel,” “the providing a separator, further comprising providing a cross-sectional area of the flow path having a substantially constant value within the included angle,” “providing a nozzle to direct the flow into a surrounding environment,” “providing a nozzle connection to the separator,” “providing an eductor connection to the separator,” and “distributing the system with at least one of instructions for use, a reservoir, and the liquid, wherein the liquid constitutes an aromatic substance selected for the scent to be introduced into the surrounding environment.” Ex. 1001, 24:39–64.

*(1)“Providing a reservoir connection to draw a liquid from a reservoir”*

Petitioner argues that Sevy teaches this limitation. Pet. 29–30. Patent Owner does not dispute Petitioner’s argument or evidence. PO Resp.

16–27. Petitioner is correct. Sevy teaches drawing liquid from a reservoir using an eductor connected to the reservoir. Ex. 1003, 8:40–59, Figs. 7, 9. Accordingly, Petitioner has shown by a preponderance of the evidence that the combination of Sevy and Cronenberg teaches this limitation of claim 17.

(2)*“Providing an eductor connected to draw the liquid from the reservoir and entrain the liquid as droplets into a flow of air”*

Petitioner argues that Sevy teaches this limitation. Pet. 30. Patent Owner does not dispute Petitioner’s argument or evidence. PO Resp. 16–27. Petitioner is correct. Sevy teaches that “[e]duction by the stream of air through the nozzle 92 draws a vacuum (e.g., reduced pressure) on the siphon 96, drawing liquid from the reservoir 18.” Ex. 1003, 8:40–44. Sevy also teaches that “[t]he liquid from the reservoir is partially atomized by the flow of air through the nozzle 92 as it educts the liquid.” *Id.* Moreover, Sevy teaches entraining the liquid from its reservoir into breathing air. *Id.* at 1:12–16. Accordingly, Petitioner has shown by a preponderance of the evidence that the combination of Sevy and Cronenberg teaches this limitation of claim 17.

(3)*“Providing a separator downstream from the eductor to receive the flow and divide out the comparatively larger sizes of droplets from the comparatively smaller sizes thereof remaining in the flow”*

Petitioner argues that Sevy teaches this limitation. Pet. 30–31. Patent Owner does not

dispute Petitioner's argument or evidence. PO Resp. 16–27. Petitioner is correct. Sevy teaches drawing liquid from a reservoir using a vacuum created by an eductor, with a separator connected downstream of the eductor. Ex. 1003, 8:40–59, Figs. 7, 9. Sevy also teaches that “[d]roplets that cannot move with the air flow, typically because they have too large a size and mass will not be able to quickly turn to follow the flow of air, and will strike the walls of the opening 100 or the separator plate 98.” *Id.* at 8:55–9:2. Accordingly, Petitioner has shown by a preponderance of the evidence that the combination of Sevy and Cronenberg teaches this limitation of claim 17.

(4)*“The providing a separator, further comprising creating a flow path for the flow spiraling axially while passing in a circumferential direction at a substantially constant radius around an included angle through a wall traversed by a spiral channel”*

Petitioner argues that the combination of Sevy and Cronenberg teaches this limitation of claim 17. Pet. 31–33. Patent Owner argues that the combination of Sevy and Cronenberg fails to teach or suggest this limitation for the same reasons discussed above with respect to the limitation of claim 1 reciting “separating out a second distribution of the droplets by passing the flow through a wall between a first chamber and a second chamber, the flow path spiraling axially and circumferentially, simultaneously and continuously, through an arcuate channel formed through the wall.” PO Resp. 16–19. Patent Owner also argues that a person of

ordinary skill in the art would not have had a reason to combine the teachings of Sevy with those of Cronenberg to arrive at this limitation of claim 17. *Id.* at 19–21, 26–27.

As discussed above with respect to claim 1, we find that a person of ordinary skill in the art would have had a reason to combine the teachings of Sevy with those of Cronenberg, and we find that the combined teachings of Sevy and Cronenberg teach providing a channel that spirals axially while passing in a circumferential direction around an included angle through a wall. These findings apply with equal force here.

With respect to the portion of this limitation requiring that the radius of curvature of the channel be “substantially constant,” Petitioner argues that Cronenberg teaches using a helical flow path of constant radius to separate droplets from an air-droplet mixture. Pet. 31–32. Patent Owner does not dispute this point. PO Resp. 16–27. Petitioner is correct, because Cronenberg’s helix 32 is depicted as having a constant radius of curvature. Ex. 1004, Fig. 3.

For these reasons, we conclude that Petitioner has shown by a preponderance of the evidence that the combination of Sevy and Cronenberg teaches this limitation of claim 17.

*(5)“The providing a separator, further comprising providing a cross-sectional area of the flow path having a substantially constant value within the included angle”*

Petitioner argues that Cronenberg teaches this limitation. Pet. 33–34. Patent Owner does not

dispute Petitioner's argument or evidence. PO Resp. 16–27. Petitioner is correct. Cronenberg teaches that its helical path is formed by a structure “with a predetermined spacing and dimensional thickness,” and it is depicted as having a constant cross-section. Ex. 1004, 3:12–21, Fig. 3. Accordingly, Petitioner has shown by a preponderance of the evidence that the combination of Sevy and Cronenberg teaches this limitation of claim 17.

(6)“*Providing a nozzle to direct the flow into a surrounding environment*”

Petitioner argues that Sevy teaches this limitation. Pet. 34. Patent Owner does not dispute Petitioner's argument or evidence. PO Resp. 16–27. Petitioner is correct. Sevy teaches that “director 17 may be turned in a particular direction to discharge a jet of air containing the cloud of smallest atomized droplets from the reservoir 18.” Ex. 1003, 9:25–28. Accordingly, Petitioner has shown by a preponderance of the evidence that the combination of Sevy and Cronenberg teaches this limitation of claim 17.

(7)“*Providing a nozzle connection to the separator*”

Petitioner argues that Sevy teaches this limitation. Pet. 34. Patent Owner does not dispute Petitioner's argument or evidence. PO Resp. 16–27. Petitioner is correct. Sevy teaches that “[t]he net flow of air passes through the aperture 122 of the separator plate 98, on its way into the passages 126 and 128 of the director 17.” Ex. 1003, 10:65–67. Accordingly, Petitioner has shown by a preponderance of the evidence that the combination

of Sevy and Cronenberg teaches this limitation of claim 17.

*(8)“Providing an eductor connection to the separator”*

Petitioner argues that Sevy teaches this limitation. Pet. 34–35. Patent Owner does not dispute Petitioner’s argument or evidence. PO Resp. 16–27. Petitioner is correct. Sevy teaches that “[e]duction by the stream of air through the nozzle 92 draws a vacuum (e.g., reduced pressure) on the siphon 96, drawing liquid from the reservoir 18.” Ex. 1003, 8:40–44. Sevy also teaches that “[t]he liquid from the siphon 96 is atomized into droplets of various sizes,” with “[t]he entire mixture of air and droplets pass[ing] through the exit orifice 119 toward the separator 120.” *Id.* at 10:37–47. Accordingly, Petitioner has shown by a preponderance of the evidence that the combination of Sevy and Cronenberg teaches this limitation of claim 17.

*(9)“Distributing the system with at least one of instructions for use, a reservoir, and the liquid, wherein the liquid constitutes an aromatic substance selected for the scent to be introduced into the surrounding environment”*

Petitioner argues that Sevy teaches this limitation. Pet. 35. Patent Owner does not dispute Petitioner’s argument or evidence. PO Resp. 16–27. Petitioner is correct. Sevy teaches both connecting a reservoir to the remainder of the system and using a bottle of essential oil “selected from a vendor” as this reservoir. Ex. 1003, 3:30–33, 6:28–29. Accordingly, Petitioner has shown by a preponderance of the



evidence that the combination of Sevy and Cronenberg teaches this limitation of claim 17.

d. Related Application

As discussed above, Petitioner has shown that a person of ordinary skill in the art would have had a reason to combine the teachings of Sevy with those of Cronenberg, as well as that the combined teachings of Sevy and Cronenberg teach or suggest the subject matter of claims 1, 3, and 17. Despite this, Patent Owner argues that we should conclude that claims 1, 3, and 17 have not been shown to be obvious because the Office has issued a Notice of Allowance of similar claims in a related patent application. PO Resp. 22–26. Specifically, Patent Owner argues that claim 40 in U.S. Patent Application Serial No. 15/297,542 (Ex. 2023, “the ’542 application”) was allowed, even though it is broader in scope than the challenged claims of the ’130 patent, and even though the examiner of the ’542 application was made aware of the prior art asserted in this proceeding. *Id.* For the reasons discussed below, we are not persuaded that the examiner’s treatment of claim 40 in the ’542 application shows the nonobviousness of the challenged claims here.

First, Patent Owner argues that claim 40 “should be considered broader in scope than claim 1 from the ’130 patent.” *Id.* at 24. But claim 40 contains limitations not present in claim 1. For example, claim 1 recites “an arcuate channel formed through the wall,” but claim 40 recites “an arcuate channel defined by a wall formed with a substantially concave internal cross section passing circumferentially and axially, simultaneously,

through the barrier.” *Id.* at 22–23; *see* Ex. 1028, 185:7–17. In addition, claim 1 recites “separating out a second distribution of the droplets,” without specifying the characteristics of the separated droplets, but claim 40 recites a limitation on the droplets that are separated, “wherein the arcuate channel has a radius and a circumferential length selected to separate out from the flow comparatively larger ones of the droplets.” PO Resp. 22–23. Given these additional limitations, we do not find that claim 40 of the ’542 application is broader in scope than claim 1 of the ’130 patent.

Moreover, Patent Owner raises the issue of the allowance of claim 40 of the ’542 application as a “secondary indic[ator] of the non-obviousness of claims 1, 3 and 17.” PO Resp. 22. But “secondary considerations” include such things as “commercial success, long felt but unsolved needs, failure of others, etc.” *Graham v. John Deere Co. of Kansas City*, 383 U.S. 1, 17 (1966). The list has expanded to include evidence of such things as licensing or copying of the invention at issue and praise by others, but Patent Owner directs us to no authority for treating the Office’s allowance of similar claims as an objective indication of non-obviousness.<sup>13</sup> PO Resp. 21–26. In any event, as discussed above, claim

---

<sup>13</sup> Even if there were authority for considering the allowance of similar claims as evidence of nonobviousness, it is not clear that we would be permitted to weigh such evidence particularly heavily in our analysis. The Office allowed the challenged claims, but that allowance does not relieve us of our duty to determine whether those claims are unpatentable. 35 U.S.C. §§ 311–319. If the Office’s allowance of the very claims at issue does not render the challenged claims non-obvious, it is unclear why the Office’s allowance of merely similar claims would do so.

40 of the '542 application has different limitations than the challenged claims, and the Examiner of claim 40 considered different evidence than that presented here. In our view, under these circumstances, it is better to evaluate each individual claim on its own merits.

For these reasons, we are not persuaded that the examiner's allowance of claim 40 in the '542 application is evidence that the challenged claims of the '130 patent would have been nonobvious.

e. Conclusion

For the reasons discussed above, we conclude that Petitioner has shown by a preponderance of the evidence that claims 1, 3, and 17 of the '130 patent would have been obvious over the combination of Sevy and Cronenberg.

*D. Asserted Obviousness over Sevy and Giroux*

Petitioner argues that the subject matter of claims 1, 3, and 17 would have been obvious to a person of ordinary skill in the art given the teachings of Sevy and Giroux. Pet. 35–43.

*1. Giroux*

Giroux relates to “a novel integrated nebulizer and particle dispersion chamber” that “provides for delivery of a vortical flow of nebulized particles to the nostrils.” Ex. 1005, at [57]. According to Giroux, “particle size and velocity characteristics determine whether a majority of a medicament will reach the deep nasal cavities, the paranasal sinuses, the bloodstream, the circulation (systematic delivery), the lungs, or drip back down the nose or mouth.” *Id.* at 2:20–25. To achieve these beneficial “size and velocity characteristics,” Giroux teaches forcing the

particles to flow through serpentine or helical baffles that cause the particles to move in a vortex after leaving the particle dispersion chamber. *Id.* at 13:32–42. Figures 14A and 14B of Giroux are reproduced below:

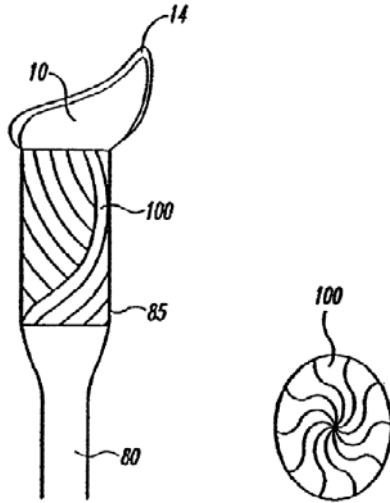

*Fig. 14A*

*Fig. 14B*

Figures 14A and 14B of Giroux, reproduced above, depict the “nasal adapter, particle dispersion chamber, and tubing” of one embodiment of Giroux, with Figure 14A being a side view and Figure 14B being a bottom view. *Id.* at 4:40–43. Particle dispersion chamber 85 includes baffles 100 that are “shaped so as to create movement of the particles while in a vortex.” *Id.* at 13:32–36. In Figures 14A and 14B, baffles 100 are “shown in a generally serpentine or helix shape.” *Id.* at 13:36–38.

## 2. Analysis

Petitioner argues that a person of ordinary skill in the art would have had reason to combine the teachings of Sevy with the teachings of Giroux and that those combined teachings teach or suggest every limitation of claims 1, 3, and 17. Pet. 35–43. As with the combination of Sevy and Cronenberg discussed above, Petitioner argues that Sevy by itself teaches all limitations of the claims except for those relating to a flow path spiraling axially and circumferentially through an arcuate channel formed through a wall (claim 1) or creating a flow path for flow spiraling axially while passing circumferentially at a substantially constant radius, and with a substantially constant cross-sectional area, around an included angle through a wall (claim 17). *Id.* As discussed above, we find that Sevy teaches each of these limitations. For the remaining limitations, Petitioner relies on a combination of Giroux and Sevy. *Id.*

Opposing Petitioner's arguments, as it did with respect to the Sevy-Cronenberg ground, Patent Owner argues that neither Sevy nor Giroux alone teaches or suggests an arcuate channel formed through a wall. PO Resp. 27–In addition, as with the Sevy-Cronenberg ground, Patent Owner argues that a person of ordinary skill in the art would not have combined the teachings of Sevy with those of Giroux. *Id.* at 28–30, 32–33. Finally, as with the Sevy-Cronenberg ground, Patent Owner argues that the allowance of the claims in the related '542 application is evidence that the similar claims here are nonobvious. *Id.* at 31–32.

a. The “Arcuate Channel Formed Through a Wall” Limitations

Petitioner argues that the limitations of the challenged claims related to the formation of an arcuate channel through a wall are taught by the combination of Sevy and Giroux. Pet. 39–40. Patent Owner argues that Giroux alone “does not teach a channel through a wall.” PO Resp. 27–28.

As discussed above with respect to the Sevy-Cronenberg ground, Sevy teaches separating some droplets from the mixed droplet-air flow by passing the flow through an orifice in a wall between a first chamber and a second chamber. Ex. 1003, 8:64–9:2 (“[T]he separator plate 98 passes the flow of air from the atomizer 16 through apertures 99 therein. Droplets that . . . have too large a size and mass will not be able to quickly turn to follow the flow of air.”). Just as Cronenberg teaches forcing a mixture of air and liquid droplets through a helical channel “to cause centrifugal force to push . . . water droplets out of the mixture,” Ex. 1004, 5:37–43, Giroux teaches causing the droplets in an air-droplet mixture to be “swirled into a vortex,” which “act[s] like a clarifier” by “send[ing] the larger droplets to the outside rings and . . . keep[ing] the smaller diameter droplets in the air stream for a longer period of time.” Ex. 1005, 8:60–62, 12:33–37. Giroux teaches achieving this result by passing “nebulized particles” through a “particle dispersion chamber” that contains “baffle[s]” that have a “serpentine or helix shape.” *Id.* at 13:32–42. Mr. Smith testifies that a person of ordinary skill in the art “would [have] replace[d] the aperture(s) in plate 98 with the helical shaped baffle of Giroux.” Ex. 1007, 58–59. Thus, the combination of Sevy and Giroux suggests separating larger

droplets from an air-droplet mixture by passing the mixture through a wall with an opening defined by a helical baffle. This satisfies the “arcuate channel formed through a wall” limitations of the challenged claims.

b. Claim 3

Claim 3 depends from claim 1 and adds a limitation requiring that “the included circumferential angle [be] from 90 degrees to 360 degrees.” Ex. 1001, 23:44–45. Petitioner argues that Giroux teaches this limitation. Pet. 40–41. Patent Owner does not dispute Petitioner’s argument or evidence. PO Resp. 27–33. Petitioner is correct. Giroux depicts its helical baffles turning through more than 90 degrees but less than 360 degrees from their entrance to their exit. Ex. 1005, Fig. 14A. Accordingly, Petitioner has shown by a preponderance of the evidence that the combination of Sevy and Cronenberg teaches the limitation of claim 3.

c. Reason to Combine

As discussed above, Sevy and Giroux teach or suggest the limitations of the challenged claims only if there was a reason for a person of ordinary skill in the art to combine their teachings. Petitioner argues that a person of ordinary skill in the art would have had such a reason. Pet. 36–38. Patent Owner disagrees. PO Resp. 28–30, 32–33.

Petitioner has shown by a preponderance of the evidence that a person of ordinary skill in the art would have had a reason to combine the teachings of Sevy with those of Giroux. As noted above, Mr. Smith testifies that a person of ordinary skill in the

art “would [have] replace[d] the aperture(s) in plate 98 with the helical shaped baffle of Giroux.” Ex. 1007, 58–59. Petitioner argues that both Sevy and Giroux teach separation of larger droplets from the air-droplet mixture, but Patent Owner argues that Giroux “has nothing whatsoever to do with separation.” Pet. 36–38; PO Resp. 29. As discussed above, Giroux teaches causing the droplets in an air-droplet mixture to be “swirled into a vortex,” which “act[s] like a clarifier” by “send[ing] the larger droplets to the outside rings and . . . keep[ing] the smaller diameter droplets in the air stream for a longer period of time.” Ex. 1005, 8:60–62, 12:33–37. Because Giroux teaches keeping smaller droplets in the air stream longer than larger droplets, it teaches separating the larger droplets from the air stream. Accordingly, both Sevy and Giroux teach methods of removing large droplets from mixtures of air and liquid droplets. Where the prior art teaches two alternative methods for achieving the same result, it likely would have been obvious to substitute one for the other. *Fout*, 675 F.2d at 301; see *KSR*, 550 U.S. at 417 (an invention is likely obvious if it is no “more than the predictable use of prior art elements according to their established functions”). Thus, Petitioner has directed us to evidence showing that it would have been obvious to substitute a channel defined by a helical baffle, as taught by Giroux, for the straight orifice in Sevy’s plate.

Patent Owner argues that replacing Sevy’s straight orifice with a helical channel based on Giroux’s teachings “would render Sevy unsatisfactory for Sevy’s intended purpose.” PO Resp. 29–30. This is allegedly because “Giroux does not teach separation, but instead teaches mixing and



directing a vortex.” *Id.* at 30. As just discussed, however, Giroux teaches “keep[ing] the smaller diameter droplets in the air stream for a longer period of time” while “send[ing] the larger droplets to the outside rings” in order to “clarif[y]” the air-droplet mixture. Ex. 1005, 8:60–62, 12:33–37. Clarifying the mixture by removing the larger droplets, while leaving the smaller droplets in place, is a means of separating the larger and smaller droplets. Thus, Giroux teaches separation. Because Giroux teaches separation, incorporating its teachings into Sevy’s method of separation is not, as Patent Owner argues, the replacement of a separation method with a mixing method, and does not render Sevy unsatisfactory for its purpose of separating the larger droplets out of the air-droplet mixture.

The same issue plagues Patent Owner’s argument that, because Giroux, Kato, and Stroia all fail to teach that their helical structures can be used to separate droplets from air-droplet mixtures, “the majority of the prior art . . . does not teach separation,” making separation using a helical structure “contrary to accepted wisdom in the art.” PO Resp. 32–33. Moreover, Patent Owner argues that this means that combining the teachings of Sevy and Giroux violates the rule of *Hedges*. *Id.* As discussed above, we do not interpret *Hedges* as establishing a rule that, where much of the prior art is silent on a particular claimed technique, practicing that technique is “contrary to accepted wisdom.”

For these reasons, we conclude that Petitioner has shown by a preponderance of the evidence that a person of ordinary skill in the art would have had a

reason to combine the teachings of Sevy with those of Giroux.

d. Related Application

Patent Owner repeats its argument that the allowance of claim 40 in the '542 application shows the nonobviousness of the challenged claims of the '130 patent. PO Resp. 31–32. As discussed above, we do not find the examiner's allowance of claim 40 in the '542 application to be persuasive evidence of the nonobviousness of the challenged claims.

e. Conclusion

For the reasons discussed above, we conclude that Petitioner has shown by a preponderance of the evidence that claims 1, 3, and 17 of the '130 patent would have been obvious over the combination of Sevy and Giroux.

*E. Asserted Obviousness over Sevy and Kato or over Sevy and Stroia*

Petitioner argues that the subject matter of claims 1, 3, and 17 would have been obvious to a person of ordinary skill in the art given the teachings of Sevy and Kato. Pet. 43–51. Petitioner also argues that the subject matter of claims 1, 3, and 17 would have been obvious to a person of ordinary skill in the art given the teachings of Sevy and Stroia. Pet. 51–60. As discussed above, we conclude that all of the challenged claims are unpatentable over both the combination of Sevy and Cronenberg and the combination of Sevy and Giroux. Accordingly, we need not reach the issue of the unpatentability of the challenged claims on either of the remaining grounds. Accordingly, in the interest

of conserving the Board's resources, we decline to reach those grounds.

*F. Motion to Exclude*

Patent Owner moves to exclude all or portions of five exhibits<sup>14</sup> filed by Petitioner, as well as to exclude

*1. Petitioner's Reply*

Patent Owner argues that the entirety of Petitioner's Reply to the Patent Owner Response should be excluded because it raises new arguments that are not responsive to issues raised in the Patent Owner Response. Paper 19, 2–3. Patent Owner is correct that, when a Reply presents new issues for the first time, the Board is not required to “parse the reply brief to determine which, if any, parts of that brief are responsive and which are improper.” *Intelligent Bio-Systems, Inc. v. Illumina Cambridge Ltd.*, 821 F.3d 1359, 1369 (Fed. Cir. 2016). The proper means for raising the question of whether a Reply raises new issues is not, however, a motion to exclude evidence. Trial Practice Guide Update<sup>15</sup> 16 (“a motion to exclude should [not] address arguments or evidence that a party believes exceed[] the proper scope of reply”). Instead, “[i]f a party believes that a brief filed by the opposing party . . . exceeds the proper scope of reply,” the party may either “request authorization to file a motion to

---

<sup>14</sup> In addition to the Exhibits discussed herein, Patent Owner originally moved to exclude Exhibits 1007 and 1027, but it has since withdrawn its motion as to these two Exhibits. Paper 22, 2.

<sup>15</sup> Office Patent Trial Practice Guide, August 2018 Update, 83 Fed. Reg. 39,989 (Aug. 2018) (providing link to Trial Practice Guide Update: <https://go.usa.gov/xU7GP> (“Trial Practice Guide Update”)).

strike” or “request authorization for further merits briefing, such as a sur-reply.” *Id.* Here, Patent Owner did not request such authorization.<sup>16</sup> Accordingly, Patent Owner’s motion to exclude Petitioner’s Reply is improper.

Even if Patent Owner’s motion to exclude the Reply were procedurally proper, we would deny it for failure to comply with the rules governing motions to exclude. A motion to exclude “must identify the objections [it preserves] in the record and must explain the objections.” 37 C.F.R. § 42.64(c). Here, the motion to exclude the Reply does not identify or explain any evidentiary objection previously made of record. Paper 19, 2–3. Patent Owner argues that its failure to identify evidentiary objections in the record, or even to object at all on the record, should be excused because 37 C.F.R. § 42.23(b), which governs the proper scope of Petitioner’s Reply, “does not include a timeframe for the argument.” Paper 22, 4. But Patent Owner asks for exclusion of the Reply in a motion to exclude, which is governed by 37 C.F.R. § 42.64(c), and which, accordingly, requires an identification of evidentiary objections in the record. To the extent that Patent Owner invites us to treat its request to exclude the Reply as something other than a motion to exclude, such as a motion to strike, Patent Owner never requested authorization to file such a motion, which is a violation of 37 C.F.R. § 42.20(b) (“A motion will not be entered without Board authorization.”). Accordingly, we decline the invitation.

---

<sup>16</sup> We note that Petitioner’s Reply was filed after the August 2018 effective date of the Trial Practice Guide Update. Reply 24 (showing filing date of September 10, 2018).

Moreover, we are not persuaded that any portion of Petitioner's Reply presents arguments that are beyond the proper scope of a Reply. Under 37 C.F.R. § 42.23(b), "[a] reply may only respond to arguments raised in the corresponding . . . patent owner response." Here, Patent Owner identifies three portions of the Reply that it contends violate this rule. Paper 19, 2–3. We are persuaded, however, that each of the identified portions responds to an argument raised in the Patent Owner Response.

First, Patent Owner argues that section I.C of the Reply, comprising "arguments regarding the one-year bar of 35 U.S.C. § 315(b)," is beyond the scope of a proper Reply. *Id.* at 2. As discussed above, the parties dispute whether Petitioner has properly and completely identified all real parties in interest, as required by 35 U.S.C. § 312(a)(2). Patent Owner raised this argument in its Response. PO Resp. 1–6. In particular, Patent Owner argued in the Response that, because of the failure to identify all real parties in interest, "[t]he Petition . . . cannot be accorded a filing date." *Id.* at 1. In the Reply, Petitioner argues that, if Patent Owner were to persuade us that the identification of real parties in interest were incomplete, dismissal of this *inter partes* review would be a particularly harsh penalty, because any new replacement petition would be barred by § 315(b). Reply 5–7. Accordingly, Petitioner argues that we should permit correction of the existing petition instead. *Id.* at 7–9. All of this is a direct response to Patent Owner's argument that the Petition should be dismissed for failure to identify all real parties in interest.

Second, Patent Owner argues that pages 9 and 10 of the Reply improperly discuss "new evidence

regarding a determination of a person having ordinary skill in the art.” Paper 19, 2. As stated expressly on the complained-of pages, however, Petitioner’s argument regarding the level of ordinary skill in the art responds to the argument offered on the same topic in the Patent Owner Response. Reply 9 (citing PO Resp. 11), 10 (citing PO Resp. 13); *see* PO Resp. 11–14 (raising issue of level of ordinary skill in the art).

Finally, Patent Owner argues that pages 11–15 and 18–20 of the Reply raise “new arguments and evidence regarding changes or alterations to the prior art relied upon in the Petition.” Paper 19, 3. But nearly every paragraph on these pages begins with the phrase “Patent Owner argues that,” before summarizing an argument from the Patent Owner Response and arguing that Patent Owner is incorrect. Reply 11–15, 18–20. Among the few paragraphs that do not take this form, nearly all of them cite the Patent Owner Response and respond to its arguments. *Id.* at 13 (citing PO Resp. 20), 18 (citing PO Resp. 26), 19 (citing PO Resp. 26). It is difficult to imagine an argument that more clearly responds to the argument in the Patent Owner Response.

Thus, Patent Owner’s motion to exclude Petitioner’s Reply is procedurally improper, and it fails to comply with the rules governing motions to exclude. Moreover, even considering the merits of the motion, we are not persuaded that the Reply exceeds the scope of a proper Reply. Accordingly, we deny the motion.

## 2. *Exhibits 1022–1025*

Patent Owner argues that Exhibits 1022–1025 should be excluded because they support the

argument in Petitioner's Reply that is allegedly beyond the scope of a proper Reply. Paper 19, 3–4. As discussed above, a motion to exclude “must identify the objections [it preserves] in the record and must explain the objections.” 37 C.F.R. § 42.64(c). Here, the motion to exclude Exhibits 1022–1025 does not identify or explain any evidentiary objections previously made of record. Paper 19, 3–4. Patent Owner argues that its failure to identify evidentiary objections in the record, or even to object at all on the record, should be excused because 37 C.F.R. § 42.23(b), which governs the proper scope of Petitioner's Reply and its supporting Exhibits, “does not include a timeframe for the argument.” Paper 22, 4. But Patent Owner asks for exclusion of these Exhibits in a motion to exclude, which is governed by 37 C.F.R. § 42.64(c), and which, accordingly, requires an identification of evidentiary objections in the record. Thus, we deny the motion to exclude Exhibits 1022–1025.

### *3. Exhibit 1028*

Patent Owner moves to exclude eleven separate portions<sup>17</sup> of Exhibit 1028, the transcript of a deposition of David A. Bell, Ph.D., P.E. Paper 19, 4–7. We discuss each portion separately below.

#### *a. Pages 163–164*

Patent Owner moves to exclude the portion of Exhibit 1028 between page 163, line 3, and page 164, line 2. Paper 19, 4–5. “An objection to the admissibility of deposition evidence must be made

---

<sup>17</sup> Patent Owner does not present its explanation of these portions of Exhibit 1028 “in order,” as required by 37 C.F.R. § 42.64(c).

during the deposition.” 37 C.F.R. § 42.64(a). In the portion of Exhibit 1028 that Patent Owner moves to exclude, there is a single objection to a single question. Ex. 1028, 163:18 (objecting to Ex. 1028, 163:14–17). Accordingly, we deny the motion to the extent it seeks to exclude anything other than the question at Ex. 1028, 163:14–17, or the response to that question, at Ex. 1028, 163:20.

As to the portions of Exhibit 1028 that are the subject of the objection on the deposition record, Patent Owner argues that the question at issue violates Federal Rules of Evidence 403 and 703. Paper 19, 4–5. Specifically, Patent Owner argues that the question “requires a speculative response from the deponent.” *Id.*; *see also* Paper 22, 6 (arguing that all hypothetical questions to Dr. Bell call for “speculative responses based on alterations or changes to the prior art not previously considered” and, accordingly, “are not reliable evidence”).<sup>18</sup> We are not persuaded that the question and answer at issue should be excluded under either rule.

Rule 403 provides that we “may exclude relevant evidence if its probative value is substantially outweighed by a danger of one or more of the following: unfair prejudice, confusing the issues, . . . undue delay, wasting time, or needlessly presenting cumulative evidence.” Fed. R. Evid. 403.<sup>19</sup> Patent

---

<sup>18</sup> The argument in Patent Owner’s Reply in support of its motion to exclude covers eleven pages. Paper 22. This far exceeds the five pages allowed for a reply in support of a motion. 37 C.F.R. § 42.24(c)(2). Notwithstanding Patent Owner’s violation of this rule, we consider the entire Reply.

<sup>19</sup> The portion of Federal Rule of Evidence 403 regarding “misleading the jury” does not apply in inter partes review proceedings. 37 C.F.R. § 42.62(b).



Owner does not explain why a question that “requires a speculative response from the deponent” necessarily calls for a response that is at danger of causing unfair prejudice, confusing the issues, undue delay, wasting time, or presenting needlessly cumulative evidence. Paper 19, 4–5. Considering each of these issues separately, we are not persuaded that it is possible for a single question and answer at a deposition, particularly a single question and answer that together take up only five lines of a nearly 300-page deposition transcript, can cause either undue delay or a waste of time. As to unfair prejudice and confusion of the issues, the question at issue simply asks Dr. Bell for his opinion as to whether Cronenberg’s helical structure would qualify as an arcuate channel if it were cut down to turn through an included angle of less than 360 degrees, which goes to the heart of an important issue in this proceeding: the scope of the claim term “arcuate channel.” Ex. 1028, 163:14–20; *see* Ex. 1028, 161:21–164:2 (providing the context for the question and the answer at issue). Further, Patent Owner does not argue that the question and answer here are cumulative of other evidence of record, or that, if they are cumulative, they are needlessly so. Thus, we deny the motion to exclude page 163, line 3, through page 164, line 2, of Exhibit 1028 under Federal Rule of Evidence 403.

Rule 703 provides that “[a]n expert may base an opinion on facts or data in the case that the expert has been made aware of or personally observed.” Fed. R. Evid. 703. Patent Owner does not explain why the presentation of a hypothetical question to an expert witness such as Dr. Bell necessarily violates this rule. Paper 19, 4–5. In fact, hypothetical

questions may be posed to expert witnesses within the scope of rule 703. Fed. R. Evid. 703 advisory committee's note ("Facts or data upon which expert opinions are based may, under the rule, be derived from three possible sources," one of which is "presentation at trial," including "the familiar hypothetical question."); *see also* Fed. R. Evid. 702 committee notes on rules—2000 amendment ("an expert opinion need not be excluded simply because it is based on hypothetical facts"). Accordingly, we deny the motion to exclude page 163, line 3, through page 164, line 2, of Exhibit 1028 under Federal Rule of Evidence 703.

b. Pages 43–45

Patent Owner moves to exclude the portion of Exhibit 1028 between page 43, line 24, and page 45, line 3, under Federal Rules of Evidence 403 and 703. Paper 19, 5. "An objection to the admissibility of deposition evidence must be made during the deposition." 37 C.F.R. § 42.64(a). In the portion of Exhibit 1028 that Patent Owner moves to exclude, there are two objections, both to the effect that the questions asked call for speculation. Ex. 1028, 44:3–4, 44:21–22. Both of the objected-to questions seek the expert's opinion regarding whether a helical structure that turns through more than 360 degrees would qualify as an arcuate channel. *Id.* at 43:24–44:2, 44:14–20. As discussed above, this sort of hypothetical question is not objectionable under rules 403 and 703 when asked of an expert witness, such as Dr. Bell. Accordingly, we deny the motion to exclude the portion of Exhibit 1028 between page 43, line 24, and page 45, line 3, under Federal Rules of Evidence 403 and 703.

## c. Page 223

Patent Owner moves to exclude the portion of Exhibit 1028 between page 223, line 13, and page 223, line 16, “as calling for a legal conclusion.” Paper 19, 5. “An objection to the admissibility of deposition evidence must be made during the deposition.” 37 C.F.R. § 42.64(a). There is no objection in the portion of Exhibit 1028 that Patent Owner moves to exclude.<sup>20</sup> Accordingly, we deny the motion to exclude the portion of Exhibit 1028 between page 223, line 13, and page 223, line 16.

## d. Page 192

Patent Owner moves to exclude the portion of Exhibit 1028 between page 192, line 10, and page 192, line 23, under Federal Rules of Evidence 403 and 703. Paper 19, 5. “An objection to the admissibility of deposition evidence must be made during the deposition.” 37 C.F.R. § 42.64(a). In the portion of Exhibit 1028 that Patent Owner moves to exclude, there is a single objection, to the effect that the question asked calls for speculation, to a single question. Ex. 1028, 192:21. Accordingly, we deny the motion to the extent it seeks to exclude anything other than the question at Ex. 1028, 192:18–20, or the response to that question, at Ex. 1028, 192:22–23. The objected-to question seeks the expert’s opinion regarding whether essential oil placed in the reservoir of a humidifier would be “entrained and diffused into” the surrounding environment. *Id.* at 192:18–20. As discussed above, this sort of hypothetical question is not objectionable under

---

<sup>20</sup> Even in the motion to exclude itself, Patent Owner does not identify any Federal Rule of Evidence violated by the question and answer at issue. Paper 19, 5.

rules 403 and 703 when asked of an expert witness, such as Dr. Bell. Accordingly, we deny the motion to exclude the portion of Exhibit 1028 between page 192, line 10, and page 192, line 23.

e. Pages 193–194

Patent Owner moves to exclude the portion of Exhibit 1028 between page 193, line 4, and page 194, line 3, under Federal Rules of Evidence 403 and 703. Paper 19, 5–6. “An objection to the admissibility of deposition evidence must be made during the deposition.” 37 C.F.R. § 42.64(a). In the portion of Exhibit 1028 that Patent Owner moves to exclude, there is a single objection, to the effect that the question asked calls for speculation, to a single question. Ex. 1028, 192:21. Accordingly, we deny the motion to the extent it seeks to exclude anything other than the question at Ex. 1028, 193:14–18, or the response to that question, at Ex. 1028, 193:20–194:3. The objected-to question seeks the expert’s opinion regarding whether placing “Mentholatum material” in the reservoir of a humidifier is an intended use of such a device. *Id.* at 193:14–18. This is a question that might invite some degree of speculation, but Dr. Bell does not speculate in his answer, responding instead that humidifiers exist that operate in a related, but different, way. *Id.* at 193:23–194:3 (“Vicks has humidifiers that can be used for that purpose,” but the oil is placed in a separate “reservoir on top, right next to the humidifier jet,” rather than in the main water reservoir.). Accordingly, we deny the motion to exclude the portion of Exhibit 1028 between page 193, line 4, and page 194, line 3.

## f. Page 182

Patent Owner moves to exclude the portion of Exhibit 1028 between page 182, line 12, and page 182, line 21, under Federal Rules of Evidence 403 and 703. Paper 19, 6. “An objection to the admissibility of deposition evidence must be made during the deposition.” 37 C.F.R. § 42.64(a). The objected-to question seeks the expert’s opinion regarding whether the helical structure of Cronenberg would constitute “an arcuate channel through a wall” if it were cut down “to have less than a single rotation from beginning to finish” and if a wall were “pack[ed] around it.” Ex. 1028, 182:12–15. As discussed above, this sort of hypothetical question is not objectionable under rules 403 and 703 when asked of an expert witness, such as Dr. Bell.

Accordingly, we deny the motion to exclude the portion of Exhibit 1028 between page 182, line 12, and page 182, line 21, under Federal Rules of Evidence 403 and 703.

## g. Pages 62–64

Patent Owner moves to exclude the portion of Exhibit 1028 between page 62, line 2, and page 64, line 5, “as calling for a legal conclusion.” Paper 19, 6. “An objection to the admissibility of deposition evidence must be made during the deposition.” 37 C.F.R. § 42.64(a). In the portion of Exhibit 1028 that Patent Owner moves to exclude, there are three objections, to three questions, each to the effect that the question asked calls for a legal conclusion. Ex. 1028, 62:13–14, 62:19, 64:2–3. Accordingly, we deny the motion to the extent it seeks to exclude anything other than the questions at Ex. 1028, 62:2–12,

62:16–18, and 63:24–64:1, or the responses to those questions, at Ex. 1028, 62:15, 62:20–22, and 64:4–5.

The objected-to questions all seek the expert’s opinion regarding the differences between claim 1 of the ’130 patent and the disclosure of Sevy. *Id.* at 62:2–12, 62:16–18, 63:24–64:1. As discussed above, the key issues in this case have to do with whether the disclosure of Sevy, when combined with the disclosure of Cronenberg, Giroux, Kato, or Stroia, renders the claims of the ’130 patent obvious. The question of obviousness is resolved on the basis of underlying factual determinations including (1) the scope and content of the prior art, (2) any differences between the claimed subject matter and the prior art, (3) the level of skill in the art, and (4) where in evidence, so-called secondary considerations. *Graham v. John Deere Co.*, 383 U.S. 1, 17-18 (1966); *see also KSR*, 550 U.S. at 407 (“While the sequence of these questions might be reordered in any particular case, the [Graham] factors continue to define the inquiry that controls.”). Thus, the issue of the differences between the claims of the ’130 patent and the disclosure of Sevy is a factual matter, not a legal one, so Patent Owner’s objection to inquiries into this matter as calling for a legal conclusion is not well-founded. Even to the extent that these questions probe Dr. Bell’s legal conclusion on the question of the obviousness of the challenged claims, at the time of the deposition, Dr. Bell had already provided direct testimony that those claims would have been non-obvious. Ex. 2024 ¶¶ 91–158. It would be improper to prohibit Petitioner from probing Dr. Bell’s legal opinions but to allow the introduction of those opinions by Patent Owner. Accordingly, we

deny the motion to exclude the portion of Exhibit 1028 between page 62, line 2, and page 64, line 5.

h. Pages 185–186

Patent Owner moves to exclude the portion of Exhibit 1028 between page 185, line 7, and page 186, line 5, “as calling for a legal conclusion.” Paper 19, 6. “An objection to the admissibility of deposition evidence must be made during the deposition.” 37 C.F.R. § 42.64(a). In the portion of Exhibit 1028 that Patent Owner moves to exclude, there is a single objection to a single question, to the effect that the question asked calls for a legal conclusion. Ex. 1028, 185:24. Accordingly, we deny the motion to the extent it seeks to exclude anything other than the question at Ex. 1028, 185:18–23, or the response to that question, at Ex. 1028, 185:25–186:5.

The objected-to question seeks the expert’s opinion regarding the relative breadth of claim 1 of the ’130 patent and claim 40 of the ’542 application. *Id.* at 185:18–23. Patent Owner argues that this opinion relates to claim construction, “a legal issue,” making it inappropriate for expert testimony. Paper 19, 6; Paper 22, 10. But Dr. Bell testified as to the construction of claim terms in his direct testimony. Ex. 2024 ¶¶ 12–13, 82, 98, 101–158. It would be improper to prohibit Petitioner from probing Dr. Bell’s legal opinions but to allow the introduction of those opinions by Patent Owner. Accordingly, we deny the motion to exclude the portion of Exhibit 1028 between page 185, line 7, and page 186, line 5.

i. Pages 237–238

Patent Owner moves to exclude the portion of Exhibit 1028 between page 237, line 12, and page

238, line 10, under Federal Rules of Evidence 403 and 703. Paper 19, 6–7. “An objection to the admissibility of deposition evidence must be made during the deposition.” 37 C.F.R. § 42.64(a). The objected-to question seeks the expert’s opinion regarding whether a person of ordinary skill in the art would have incorporated a helical structure into Sevy’s separator plate orifice or into some other part of Sevy. Ex. 1028, 237:12–19. As discussed above, this sort of hypothetical question is not objectionable under rules 403 and 703 when asked of an expert witness, such as Dr. Bell. Accordingly, we deny the motion to exclude the portion of Exhibit 1028 between page 237, line 12, and page 238, line 10, under Federal Rules of Evidence 403 and 703.

j. Page 249

Patent Owner moves to exclude the portion of Exhibit 1028 between page 249, line 9, and page 249, line 25, under Federal Rules of Evidence 403 and 703. Paper 19, 7. “An objection to the admissibility of deposition evidence must be made during the deposition.” 37 C.F.R. § 42.64(a). There is no objection in the portion of Exhibit 1028 that Patent Owner moves to exclude. Accordingly, we deny the motion to exclude the portion of Exhibit 1028 between page 249, line 9, and page 249, line 25.

k. Page 153

Patent Owner moves to exclude the portion of Exhibit 1028 between page 153, line 7, and page 153, line 18, “as calling for a legal conclusion.” Paper 19, 7. “An objection to the admissibility of deposition evidence must be made during the deposition.” 37 C.F.R. § 42.64(a). There is no objection in the portion of Exhibit 1028 that Patent Owner moves to



exclude.<sup>21</sup> Accordingly, we deny the motion to exclude the portion of Exhibit 1028 between page 153, line 7, and page 153, line 18.

*4. Conclusion with Respect to Motion to Exclude*

For the reasons discussed above, we deny Patent Owner's motion to exclude (1) Petitioner's Reply, (2) the entirety of Exhibits 1022–1025, and (3) eleven separate portions of Exhibit 1028.

CONCLUSION

Upon consideration of the Petition, Response, Reply, the briefing on Patent Owner's motion to exclude evidence, and the evidence before us, we determine that Petitioner has proven by a preponderance of the evidence that claims 1, 3, and 17 would have been obvious over either the combination of Sevy and Cronenberg or the combination of Sevy and Giroux. We determine that Petitioner has not proven by a preponderance of the evidence that claims 1, 3, and 17 would have been obvious over either the combination of Sevy and Kato or the combination of Sevy and Stroia. We also determine that Petitioner's identification of real parties in interest was not incomplete either for failure to identify Puzhen Life HK or for failure to identify doTERRA. Finally, we deny Patent Owner's motion to exclude Petitioner's Reply and several evidentiary exhibits.

---

<sup>21</sup> Even in the motion to exclude itself, Patent Owner does not identify any Federal Rule of Evidence violated by the question and answer at issue. Paper 19, 5.

ORDER

It is hereby

ORDERED that Petitioner has proven by a preponderance of the evidence that claims 1, 3, and 17 of U.S. Patent No. 9,415,130 B2 are unpatentable;

FURTHER ORDERED that Petitioner has satisfied the requirement of 35 U.S.C. § 312(a)(2) that it identify all real parties in interest;

FURTHER ORDERED that Patent Owner's motion to exclude is denied;

FURTHER ORDERED that, pursuant to 35 U.S.C. § 318(b), upon expiration of the time for appeal of this decision, or the termination of any such appeal, a certificate shall issue canceling claims 1, 3, and 17 of U.S. Patent No. 9,415,130 B2; and

FURTHER ORDERED that, because this is a Final Written Decision, parties to the proceeding seeking judicial review of the decision must comply with the notice and service requirements of 37 C.F.R. § 90.2.

PETITIONER:

Mark A. Miller

Bradley B. Jensen

DORSEY & WHITNEY LLP

miller.mark@dorsey.com

jensen.bradley@dorsey.com

PATENT OWNER:

Gordon K. Hill

PATE BAIRD, PLLC

ghill@patebaird.com

**[ENTERED: JULY 13, 2020]**

NOTE: This order is nonprecedential.

---

United States Court of Appeals  
for the Federal Circuit

---

**ESIP SERIES 2, LLC,**  
*Appellant*

v.

**PUZHEN LIFE USA, LLC,**  
*Appellee*

---

2019-1659

---

Appeal from the United States Patent and  
Trademark Office, Patent Trial and Appeal Board in  
No. IPR2017- 02197.

---

**ON PETITION FOR PANEL REHEARING AND  
REHEARING EN BANC**

---

Before PROST, *Chief Judge*, NEWMAN, LOURIE,  
DYK, MOORE, O'MALLEY, REYNA, WALLACH,  
TARANTO, CHEN, HUGHES, and STOLL,  
*Circuit Judges.*

PER CURIAM.

**ORDER**

Appellant ESIP Series 2, LLC filed a combined  
petition for panel rehearing and rehearing en banc.  
The petition was referred to the panel that heard the

appeal, and there- after the petition for rehearing en banc was referred to the circuit judges who are in regular active service.

Upon consideration thereof.

IT IS ORDERED THAT:

The petition for panel rehearing is denied.

The petition for rehearing en banc is denied.

The mandate of the court will issue on July 20, 2020.

FOR THE COURT

July 13, 2020

Date

/s/ Peter R. Marksteiner

Peter R. Marksteiner

Clerk of Court

## RELEVANT CONSTITUTIONAL AND STATUTORY PROVISIONS

1. The United States Constitution provides in relevant part as follows:

### **Amendment V**

No person shall be held to answer for a capital, or otherwise infamous crime, unless on a presentment or indictment of a Grand Jury, except in cases arising in the land or naval forces, or in the Militia, when in actual service in time of War or public danger; nor shall any person be subject for the same offense to be twice put in jeopardy of life or limb; nor shall be compelled in any criminal case to be a witness against himself, nor be deprived of life, liberty, or property, without due process of law; nor shall private property be taken for public use, without just compensation.

2. Title 5 of the United States Code provides in relevant part as follows:

### **§ 706. Scope of review**

To the extent necessary to decision and when presented, the reviewing court shall decide all relevant questions of law, interpret constitutional and statutory provisions, and determine the meaning or applicability of the terms of an agency action. The reviewing court shall –

(1) compel agency action unlawfully withheld or unreasonably delayed; and

(2) hold unlawful and set aside agency action, findings, and conclusions found to be –

(A) arbitrary, capricious, an abuse of discretion, or otherwise not in accordance with law;

(B) contrary to constitutional right, power, privilege, or immunity;

(C) in excess of statutory jurisdiction, authority, or limitations, or short of statutory right;

(D) without observance of procedure required by law;

(E) unsupported by substantial evidence in a case subject to sections 556 and 557 of this title or otherwise reviewed on the record of an agency hearing provided by statute; or

(F) unwarranted by the facts to the extent that the facts are subject to trial de novo by the reviewing court.

In making the foregoing determinations, the court shall review the whole record or those parts of it cited by a party, and due account shall be taken of the rule of prejudicial error.

3. Title 35 of the United States Code provides in relevant part as follows:

**§ 101. Inventions patentable**

Whoever invents or discovers any new and useful process, machine, manufacture, or composition of matter, or any new and useful improvement thereof, may obtain a patent therefor, subject to the conditions and requirements of this title.

**§ 103. Conditions for patentability; non-obvious subject matter**

A patent for a claimed invention may not be obtained, notwithstanding that the claimed invention is not identically disclosed as set forth in section 102, if the differences between the claimed invention and the prior art are such that the claimed invention as a whole would have been obvious before the effective filing date of the claimed invention to a person having ordinary skill in the art to which the claimed invention pertains. Patentability shall not be negated by the manner in which the invention was made.

**§ 261. Ownership; assignment**

Subject to the provisions of this title, patents shall have the attributes of personal property. The Patent and Trademark Office shall maintain a register of interests in patents and applications for patents and shall record any document related thereto upon request, and may require a fee therefor.

Applications for patent, patents, or any interest therein, shall be assignable in law by an instrument in writing. The applicant, patentee, or his assigns or legal representatives may in like manner grant and convey an exclusive right under his application for patent, or patents, to the whole or any specified part of the United States.

A certificate of acknowledgment under the hand and official seal of a person authorized to administer oaths within the United States, or, in a foreign country, of a diplomatic or consular officer of the United States or an officer authorized to administer oaths whose authority is proved by a certificate of a

diplomatic or consular officer of the United States, or apostille of an official designated by a foreign country which, by treaty or convention, accords like effect to apostilles of designated officials in the United States, shall be prima facie evidence of the execution of an assignment, grant or conveyance of a patent or application for patent.

An interest that constitutes an assignment, grant or conveyance shall be void as against any subsequent purchaser or mortgagee for a valuable consideration, without notice, unless it is recorded in the Patent and Trademark Office within three months from its date or prior to the date of such subsequent purchase or mortgage.

### **§ 271. Infringement of patent**

(a) Except as otherwise provided in this title, whoever without authority makes, uses, offers to sell, or sells any patented invention, within the United States or imports into the United States any patented invention during the term of the patent therefor, infringes the patent.

### **§ 311. Inter partes review**

(a) IN GENERAL. – Subject to the provisions of this chapter, a person who is not the owner of a patent may file with the Office a petition to institute an inter partes review of the patent. The Director shall establish, by regulation, fees to be paid by the person requesting the review, in such amounts as the Director determines to be reasonable, considering the aggregate costs of the review.

(b) SCOPE. – A petitioner in an inter partes review may request to cancel as unpatentable 1 or more claims of a patent only on a ground that could



be raised under section 102 or 103 and only on the basis of prior art consisting of patents or printed publications.

(c) **FILING DEADLINE.** – A petition for inter partes review shall be filed after the later of either –

(1) the date that is 9 months after the grant of a patent; or

(2) if a post-grant review is instituted under chapter 32, the date of the termination of such post-grant review.

### **§ 312. Petitions**

(a) **REQUIREMENTS OF PETITION.** – A petition filed under section 311 may be considered only if –

(1) the petition is accompanied by payment of the fee established by the Director under section 311;

(2) the petition identifies all real parties in interest;

(3) the petition identifies, in writing and with particularity, each claim challenged, the grounds on which the challenge to each claim is based, and the evidence that supports the grounds for the challenge to each claim, including –

(A) copies of patents and printed publications that the petitioner relies upon in support of the petition; and

(B) affidavits or declarations of supporting evidence and opinions, if the petitioner relies on expert opinions;

(4) the petition provides such other information as the Director may require by regulation; and

(5) the petitioner provides copies of any of the documents required under paragraphs (2), (3), and (4) to the patent owner or, if applicable, the designated representative of the patent owner.

(b) PUBLIC AVAILABILITY. – As soon as practicable after the receipt of a petition under section 311, the Director shall make the petition available to the public.

### **§ 313. Preliminary response to petition**

If an inter partes review petition is filed under section 311, the patent owner shall have the right to file a preliminary response to the petition, within a time period set by the Director, that sets forth reasons why no inter partes review should be instituted based upon the failure of the petition to meet any requirement of this chapter.

### **§ 314. Institution of inter partes review**

(a) THRESHOLD. – The Director may not authorize an inter partes review to be instituted unless the Director determines that the information presented in the petition filed under section 311 and any response filed under section 313 shows that there is a reasonable likelihood that the petitioner would prevail with respect to at least 1 of the claims challenged in the petition.

(b) TIMING. – The Director shall determine whether to institute an inter partes review under this chapter pursuant to a petition filed under section 311 within 3 months after –

(1) receiving a preliminary response to the petition under section 313; or

(2) if no such preliminary response is filed, the last date on which such response may be filed.

(c) NOTICE. – The Director shall notify the petitioner and patent owner, in writing, of the Director’s determination under subsection (a), and shall make such notice available to the public as soon as is practicable. Such notice shall include the date on which the review shall commence.

(d) NO APPEAL. – The determination by the Director whether to institute an inter partes review under this section shall be final and nonappealable.

### **§ 315. Relation to other proceedings or actions**

(a) INFRINGER’S CIVIL ACTION. –

(1) INTER PARTES REVIEW BARRED BY CIVIL ACTION. – An inter partes review may not be instituted if, before the date on which the petition for such a review is filed, the petitioner or real party in interest filed a civil action challenging the validity of a claim of the patent.

(2) STAY OF CIVIL ACTION. – If the petitioner or real party in interest files a civil action challenging the validity of a claim of the patent on or after the date on which the petitioner files a petition for inter partes review of the patent, that civil action shall be automatically stayed until either –

(A) the patent owner moves the court to lift the stay;

(B) the patent owner files a civil action or counterclaim alleging that the petitioner or real party in interest has infringed the patent; or

(C) the petitioner or real party in interest moves the court to dismiss the civil action.

(3) TREATMENT OF COUNTERCLAIM. – A counterclaim challenging the validity of a claim of a patent does not constitute a civil action challenging the validity of a claim of a patent for purposes of this subsection.

(b) PATENT OWNER'S ACTION. – An inter partes review may not be instituted if the petition requesting the proceeding is filed more than 1 year after the date on which the petitioner, real party in interest, or privy of the petitioner is served with a complaint alleging infringement of the patent. The time limitation set forth in the preceding sentence shall not apply to a request for joinder under subsection (c).

(c) JOINDER. – If the Director institutes an inter partes review, the Director, in his or her discretion, may join as a party to that inter partes review any person who properly files a petition under section 311 that the Director, after receiving a preliminary response under section 313 or the expiration of the time for filing such a response, determines warrants the institution of an inter partes review under section 314.

(d) MULTIPLE PROCEEDINGS. – Notwithstanding sections 135(a), 251, and 252, and chapter 30, during the pendency of an inter partes review, if another

proceeding or matter involving the patent is before the Office, the Director may determine the manner in which the inter partes review or other proceeding or matter may proceed, including providing for a stay, transfer, consolidation, or termination of any such matter or proceeding.

(e) ESTOPPEL. –

(1) PROCEEDINGS BEFORE THE OFFICE. – The petitioner in an inter partes review of a claim in a patent under this chapter that results in a final written decision under section 318(a), or the real party in interest or privy of the petitioner, may not request or maintain a proceeding before the Office with respect to that claim on any ground that the petitioner raised or reasonably could have raised during that inter partes review.

(2) Civil actions and other proceedings. – The petitioner in an inter partes review of a claim in a patent under this chapter that results in a final written decision under section 318(a), or the real party in interest or privy of the petitioner, may not assert either in a civil action arising in whole or in part under section 1338 of title 28 or in a proceeding before the International Trade Commission under section 337 of the Tariff Act of 1930 that the claim is invalid on any ground that the petitioner raised or reasonably could have raised during that inter partes review.

### **§ 318. Decision of the Board**

(a) FINAL WRITTEN DECISION. – In an inter partes review is instituted and not dismissed under this

chapter, the Patent Trial and Appeal Board shall issue a final written decision with respect to the patentability of any patent claim challenged by the petitioner and any new claim added under section 316(d).

(b) CERTIFICATE. – If the Patent Trial and Appeal Board issues a final written decision under subsection (a) and the time for appeal has expired or any appeal has terminated, the Director shall issue and publish a certificate canceling any claim of the patent finally determined to be unpatentable, confirming any claim of the patent determined to be patentable, and incorporating in the patent by operation of the certificate any new and amended claim determined to be patentable.

(c) INTERVENING RIGHTS. – Any proposed amended or new claim determined to be patentable and incorporated into a patent following an inter partes review under this chapter shall have the same effect as that specified in section 252 for reissued patents on the right of any person who made, purchased, or used within the United States, or imported into the United States, anything patented by such proposed amended or new claim, or who made substantial preparation therefor, before the issuance of a certificate under subsection (b).

(d) DATA ON LENGTH OF REVIEW. – The Office shall make available to the public data describing the length of time between the institution of, and the issuance of a final written decision under subsection (a) for, each inter partes review.

**§ 319. Appeal**

A party dissatisfied with the final written decision of the Patent Trial and Appeal Board under section 318(a) may appeal the decision pursuant to sections 141 through 144. Any party to the inter partes review shall have the right to be a party to the appeal.