

No. _____

In the
Supreme Court of the United States

GENERAL ELECTRIC COMPANY,

Petitioner,

v.

UNITED TECHNOLOGIES CORPORATION,

Respondent.

ON PETITION FOR A WRIT OF CERTIORARI
TO THE UNITED STATES COURT OF APPEALS
FOR THE FEDERAL CIRCUIT

PETITION FOR A WRIT OF CERTIORARI

SHAY DVORETZKY
AMANDA K. RICE
JONES DAY
51 Louisiana Ave., NW
Washington, DC 20001
(202) 879-3939

GREGORY G. GARRE
Counsel of Record
ROMAN MARTINEZ
TYCE R. WALTERS
LATHAM & WATKINS LLP
555 Eleventh Street, NW
Suite 1000
Washington, DC 20004
(202) 637-2207
gregory.garre@lw.com

Counsel for Petitioner

QUESTION PRESENTED

This Court and courts of appeals across the country have long held that government action that subjects parties to competitive harm, such as by increasing the burdens or costs of competition, satisfies Article III's injury-in-fact requirement. In determining whether a petitioner in an inter partes review (IPR) proceeding has Article III standing to appeal a final written decision by the Patent and Trademark Office (PTO), however, the Federal Circuit has repeatedly held that such competitive harm does not constitute an injury-in-fact. Instead, the court has held that to establish standing, a petitioner who is not already the subject of a patent infringement claim concerning the challenged patent must show that it has "concrete plans for future activity that creates a substantial risk of future infringement." App. 8a (citation omitted). As Judge Hughes recognized in this case, the Federal Circuit has thus erected a "patent-specific approach to the doctrine of competitor standing that is out of step with Supreme Court precedent." *Id.* at 9a (Hughes, J., concurring in the judgment).

The question presented is:

Whether competitive harm alone suffices to confer Article III standing to appeal an IPR determination, or whether an appellant must also show concrete plans for future activity that creates a substantial risk of a future patent infringement action.

RULE 29.6 STATEMENT

Pursuant to Rule 29.6 of the Rule of this Court, petitioner General Electric Company states that it has no parent corporation, and no publicly held company owns 10% or more of its stock.

LIST OF RELATED PROCEEDINGS

Pursuant to Supreme Court Rule 14.1(b)(iii), petitioner states that there are no proceedings directly related to this case in this Court.

TABLE OF CONTENTS

	Page
QUESTION PRESENTED	i
RULE 29.6 STATEMENT.....	ii
LIST OF RELATED PROCEEDINGS	iii
TABLE OF AUTHORITIES	vii
OPINIONS AND ORDERS BELOW.....	1
JURISDICTION.....	1
CONSTITUTIONAL AND STATUTORY PROVISIONS INVOLVED.....	1
INTRODUCTION	1
STATEMENT OF THE CASE.....	5
A. Legal Background.....	5
B. Factual Background.....	7
C. This Proceeding.....	8
REASONS FOR GRANTING THE WRIT.....	12
I. The Federal Circuit’s Heightened Competitor-Standing Rule Conflicts With Decisions Of Other Circuits.....	14
A. The Federal Circuit’s Heightened Standing Requirement For IPR Appeals.....	14
B. In Other Circuits, Competitive Harm Alone Confers Standing.....	17
II. The Federal Circuit’s Heightened Competitor-Standing Rule Also Conflicts With Decisions Of This Court.....	24

TABLE OF CONTENTS—Continued

	Page
A. The Federal Circuit’s Rule Conflicts With This Court’s Standing Decisions	24
B. The Federal Circuit Disregarded This Court’s Admonitions That Patent Law Is Governed By The Same Basic Principles As Other Areas Of Civil Litigation.....	27
C. The Federal Circuit’s Heightened Standing Requirement Is Particularly Inappropriate In The IPR Context.....	29
III. The Question Presented Is Exceptionally Important And Warrants Review.....	32
CONCLUSION.....	34

APPENDIX

Opinion of the United States Court of Appeals for the Federal Circuit, <i>General Electric Co. v. United Technologies Corp.</i> , 928 F.3d 1349 (Fed. Cir. 2019)	1a
Final Written Decision of the United States Patent and Trademark Office Before the Patent Trial and Appeal Board, <i>General Electric Co. v. United Technologies Corp.</i> , Case IPR2016-00531 (P.T.O. June 26, 2017).....	19a

TABLE OF CONTENTS—Continued

	Page
Order of the United States Court of Appeals for the Federal Circuit Denying Petition for Rehearing En Banc, <i>General Electric Co. v. United Technologies Corp.</i> , No. 2017-2497 (Fed. Cir. Oct. 15, 2019)	54a
U.S. Const. art. III, § 2.....	56a
35 U.S.C. § 311	57a
35 U.S.C. § 315(e).....	58a
35 U.S.C. § 319.....	59a
Declaration of Alexander E. Long in Support of General Electric Company’s Opposition to Appellee’s Motion to Dismiss, <i>General Electric Co. v. United Technologies Corp.</i> , No. 2017-2497 (Fed. Cir. Jan. 16, 2018), ECF No. 36 (without exhibits)	60a
Supplemental Declaration of Alexander E. Long in Support of General Electric Company’s Standing, <i>General Electric Co. v. United Technologies Corp.</i> , No. 2017-2497 (Fed. Cir. Nov. 28, 2018) (redacted), ECF No. 63 (without exhibit)	69a

TABLE OF AUTHORITIES

	Page(s)
CASES	
<i>ABB Inc. v. Cooper Industries, LLC</i> , 635 F.3d 1345 (Fed. Cir. 2011)	29
<i>Abortion Rights Mobilization Inc. v. Baker</i> (<i>In re United States Catholic</i> <i>Conference</i>), 885 F.2d 1020 (2d Cir. 1989)	21
<i>Adams v. Watson</i> , 10 F.3d 915 (1st Cir. 1993)	17, 21
<i>Altaire Pharmaceuticals, Inc. v. Paragon</i> <i>Biotech, Inc.</i> , 889 F.3d 1274 (Fed. Cir.), <i>remand order</i> <i>modified by stipulation</i> , 738 F. App'x 1017 (Fed. Cir. 2018)	16
<i>American Institute of Certified Public</i> <i>Accountants v. IRS</i> , 804 F.3d 1193 (D.C. Cir. 2015)	17
<i>Americans for Safe Access v. DEA</i> , 706 F.3d 438 (D.C. Cir.), <i>cert. denied</i> , 571 U.S. 885 (2013)	4
<i>Association of Data Processing Service</i> <i>Organizations, Inc. v. Camp</i> , 397 U.S. 150 (1970)	25
<i>AVX Corp. v. Presidio Components, Inc.</i> , 923 F.3d 1357 (Fed. Cir. 2019)	<i>passim</i>

TABLE OF AUTHORITIES—Continued

	Page(s)
<i>Becker v. FEC</i> , 230 F.3d 381 (1st Cir. 2000), <i>cert.</i> <i>denied</i> , 532 U.S. 1007 (2001).....	23
<i>Canadian Lumber Trade Alliance v. United States</i> , 517 F.3d 1319 (Fed. Cir. 2008), <i>cert.</i> <i>denied</i> , 555 U.S. 819 (2008).....	28
<i>Carpenters Industrial Council v. Zinke</i> , 854 F.3d 1 (D.C. Cir. 2017).....	27
<i>Center for Reproductive Law & Policy v. Bush</i> , 304 F.3d 183 (2d Cir. 2002)	17, 21
<i>Clinton v. City of New York</i> , 524 U.S. 417 (1998).....	2, 13, 24, 25
<i>Consumer Watchdog v. Wisconsin Alumni Research Foundation</i> , 753 F.3d 1258 (Fed. Cir. 2014), <i>cert.</i> <i>denied</i> , 574 U.S. 1153 (2015).....	23
<i>Cooper v. Texas Alcoholic Beverage Commission</i> , 820 F.3d 730 (5th Cir.), <i>cert. denied</i> , 137 S. Ct. 494 (2016).....	20
<i>Cuozzo Speed Technologies, LLC v. Lee</i> , 136 S. Ct. 2131 (2016).....	3, 5
<i>Cyzewski v. Jevic Holding Corp.</i> , 137 S. Ct. 973 (2017).....	13, 27

TABLE OF AUTHORITIES—Continued

	Page(s)
<i>DaimlerChrysler Corp. v. Cuno</i> , 547 U.S. 332 (2006).....	32
<i>Danvers Motor Co. v. Ford Motor Co.</i> , 432 F.3d 286 (3d Cir. 2005)	13
<i>Deposit Guaranty National Bank v. Roper</i> , 445 U.S. 326 (1980).....	31
<i>E.I. DuPont de Nemours & Co. v. Synvina</i> <i>C.V.</i> , 904 F.3d 996 (Fed. Cir. 2018).....	16
<i>eBay Inc. v. MercExchange, L.L.C.</i> , 547 U.S. 388 (2006).....	2, 28
<i>Ecosystem Investment Partners v. Crosby</i> <i>Dredging, L.L.C.</i> , 729 F. App'x 287 (5th Cir. 2018)	27
<i>Electrical Fittings Corp. v. Thomas & Betts</i> <i>Co.</i> , 307 U.S. 241 (1939).....	31
<i>Fisher & Paykel Healthcare Ltd. v. ResMed</i> <i>Ltd.</i> , 789 F. App'x 877 (Fed. Cir. 2019).....	16
<i>Holmes Group, Inc. v. Vornado Air</i> <i>Circulation Systems, Inc.</i> , 535 U.S. 826 (2002).....	28

TABLE OF AUTHORITIES—Continued

	Page(s)
<i>International Brotherhood of Teamsters v. DOT,</i> 724 F.3d 206 (D.C. Cir. 2013).....	20
<i>Investment Co. Institute v. Camp,</i> 401 U.S. 617 (1971).....	25
<i>JTEKT Corp. v. GKN Automotive Ltd.,</i> 898 F.3d 1217 (Fed. Cir. 2018), <i>cert. denied</i> , 139 S. Ct. 2713 (2019).....	15
<i>KSR International Co. v. Teleflex Inc.,</i> 550 U.S. 398 (2007).....	9
<i>Lujan v. Defenders of Wildlife,</i> 504 U.S. 555 (1992).....	13
<i>Marshall & Ilsley Corp. v. Heimann,</i> 652 F.2d 685 (7th Cir. 1981), <i>cert. denied</i> , 455 U.S. 481 (1982).....	17, 22
<i>Mata v. Lynch,</i> 135 S. Ct. 2150 (2015).....	12
<i>MedImmune, Inc. v. Genentech, Inc.,</i> 549 U.S. 118 (2007).....	2, 4, 28, 29
<i>Mendoza v. Perez,</i> 754 F.3d 1002 (D.C. Cir. 2014).....	19, 22
<i>Momenta Pharmaceuticals, Inc. v. Bristol-Myers Squibb Co.,</i> 915 F.3d 764 (Fed. Cir. 2019).....	16

TABLE OF AUTHORITIES—Continued

	Page(s)
<i>Oil States Energy Services, LLC v. Greene’s Energy Group, LLC</i> , 138 S. Ct. 1365 (2018).....	6, 31
<i>Phigenix, Inc. v. Immunogen, Inc.</i> , 845 F.3d 1168 (Fed. Cir. 2017).....	16
<i>SCA Hygiene Products Aktiebolag v. First Quality Baby Products, LLC</i> , 137 S. Ct. 954 (2017).....	1, 28
<i>Shays v. FEC</i> , 414 F.3d 76 (D.C. Cir. 2005).....	17, 20, 22
<i>Sherley v. Sebelius</i> , 610 F.3d 69 (D.C. Cir. 2010).....	<i>passim</i>
<i>Simmons v. ICC</i> , 900 F.2d 1023 (7th Cir. 1990), <i>cert. denied</i> , 499 U.S. 919 (1991).....	20
<i>Spokeo, Inc. v. Robins</i> , 136 S. Ct. 1540 (2016).....	30
<i>TrafficSchool.com, Inc. v. Edriver Inc.</i> , 653 F.3d 820 (9th Cir. 2011).....	17, 22
<i>UPS Worldwide Forwarding, Inc. v. United States Postal Service</i> , 66 F.3d 621 (3d Cir. 1995), <i>cert. denied</i> , 516 U.S. 1171 (1996).....	17

TABLE OF AUTHORITIES—Continued

	Page(s)
<i>Vermont Agency of Natural Resources v. United States ex rel. Stevens</i> , 529 U.S. 765 (2000).....	31
<i>WesternGeco LLC v. ION Geophysical Corp.</i> , 138 S. Ct. 2129 (2018).....	26

**CONSTITUTIONAL, STATUTORY AND
REGULATORY PROVISIONS**

U.S. Const. art. III, § 2.....	1
28 U.S.C. § 1254(1).....	1
35 U.S.C. § 141	6
35 U.S.C. § 142	6
35 U.S.C. § 143	6
35 U.S.C. § 144	6
35 U.S.C. § 311(a).....	5, 30
35 U.S.C. § 311(b).....	5
35 U.S.C. § 314(a).....	5
35 U.S.C. § 315(c).....	30
35 U.S.C. § 315(e).....	30
35 U.S.C. § 315(e)(2)	6

TABLE OF AUTHORITIES—Continued

	Page(s)
35 U.S.C. § 316	5
35 U.S.C. § 318(a).....	6
35 U.S.C. § 319.....	3, 6, 9, 30
Pub. L. No. 112-29, 125 Stat. 284 (2011)	1
37 C.F.R. § 42.1 <i>et seq.</i>	5

OTHER AUTHORITIES

3 K. Davis & R. Pierce, <i>Administrative Law Treatise</i> (3d ed. 1994).....	2, 24
Matthew Dowd & Jonathan Stroud, <i>Will Fed. Circ. Consider The Competitor Standing Doctrine?</i> , Law360 (Dec. 18, 2018), https://www.law360.com/articles/ 1110478	13, 22
FTC, <i>To Promote Innovation: The Proper Balance of Competition and Patent Law and Policy: Executive Summary</i> (2003)	5
GE Aviation, <i>Aviation History</i> , https://www.geaviation.com/company/aviation-history (last visited Feb. 7, 2020)	7
Richard Godson, <i>A Practical Treatise on the Law of Patents for Inventions and of Copyright</i> (1832)	31

TABLE OF AUTHORITIES—Continued

	Page(s)
W.M. Hindmarch, <i>A Treatise on the Law Relative to Patent Privileges for the Sole Use of Inventions</i> (1847)	31
H.R. Rep. No. 112-98, pt. 1 (2011)	5, 33
<i>Patent Quality Improvement: Post-Grant Opposition: Hearing before the Subcomm. on Courts, the Internet, and Intellectual Prop. of the H. Comm. on the Judiciary</i> , 108th Cong. (2004)	32

PETITION FOR A WRIT OF CERTIORARI

Petitioner General Electric Company (GE) respectfully petitions this Court for a writ of certiorari to review the judgment of the United States Court of Appeals for the Federal Circuit in this case.

OPINIONS AND ORDERS BELOW

The Patent Trial and Appeal Board's Final Written Decision (App. 19a-53a) is unreported. The Federal Circuit's opinion (App. 1a-18a) is reported at 928 F.3d 1349. The Federal Circuit's order denying rehearing en banc (App. 54a-55a) is unreported.

JURISDICTION

The Federal Circuit entered its opinion on July 10, 2019. App. 1a. GE timely filed a petition for rehearing en banc, which the Federal Circuit denied on October 15, 2019. *Id.* at 55a. On January 6, 2020, the Chief Justice extended the time for filing a petition for a writ of certiorari to and including February 12, 2020. This Court has jurisdiction under 28 U.S.C. § 1254(1).

CONSTITUTIONAL AND STATUTORY PROVISIONS INVOLVED

Article III, § 2, of the United States Constitution as well as pertinent provisions of the Leahy-Smith America Invents Act, Pub. L. No. 112-29, 125 Stat. 284 (2011), are reprinted at App. 56a-59a.

INTRODUCTION

This Court has repeatedly rejected the Federal Circuit's attempts to create patent-specific exceptions to generally applicable doctrines governing civil litigation in the federal courts. *See, e.g., SCA Hygiene Prods. Aktiebolag v. First Quality Baby Prods., LLC,*

137 S. Ct. 954, 963-64 (2017); *MedImmune, Inc. v. Genentech, Inc.*, 549 U.S. 118, 132 & n.11 (2007); *eBay Inc. v. MercExchange, L.L.C.*, 547 U.S. 388, 391-93 (2006). This petition seeks review of another such rule: a heightened requirement for establishing Article III standing to appeal final decisions by the Patent Trial and Appeal Board of the Patent and Trademark Office (PTO) in inter partes review (IPR) proceedings challenging the validity of patents.

The Court has long held that government action that subjects parties to competitive harm satisfies Article III's injury-in-fact requirement. *See Clinton v. City of N.Y.*, 524 U.S. 417, 433 (1998) (citing 3 K. Davis & R. Pierce, *Administrative Law Treatise* 13-14 (3d ed. 1994)). Following this Court's lead, the D.C. Circuit and other courts of appeals have applied a common-sense inquiry, grounded in the "basic law of economics," to assess whether (and how) a challenged action impacts competition. *Sherley v. Sebelius*, 610 F.3d 69, 72 (D.C. Cir. 2010) (citation omitted). Although "[t]he form of that [competitive] injury may vary," these courts have held that actions that unlawfully benefit a plaintiff's business rival cause economic injury that gives rise to standing. *Id.* Especially in the D.C. Circuit, competitor standing has served as a critical springboard for challenging a broad spectrum of administrative actions.

This case concerns the showing required to establish standing to appeal a final decision of the PTO rejecting an IPR challenge under the America Invents Act (AIA), one of the most important developments in patent law in the past century. As this Court has recognized, Congress enacted the AIA—and its new, IPR procedure—to "protect the public's 'paramount interest in seeing that patent

monopolies . . . are kept within their legitimate scope.” *Cuozzo Speed Techs., LLC v. Lee*, 136 S. Ct. 2131, 2144 (2016) (alteration in original) (citation omitted). To advance that “paramount interest,” Congress allowed anyone to file an IPR petition and authorized any “party dissatisfied with [a] final written decision” of the PTO to appeal the decision to the Federal Circuit. 35 U.S.C. § 319. The question here is what a dissatisfied party must show when it competes in an area impacted by the patent at issue in the IPR proceeding, but is not yet subject to actual or threatened patent infringement litigation.

As Judge Hughes observed below, instead of answering that question by applying the same competitor-standing doctrine used by this Court and other circuits, the Federal Circuit has devised a special, “patent-specific” rule for IPR appeals. App. 9a (Hughes, J., concurring in the judgment). Under that rule, showing that an IPR petitioner directly competes with the patent owner and will suffer economic injury as a result of the PTO’s decision is not sufficient to establish injury-in-fact; instead, a petitioner must show concrete current or future plans to infringe the patent at issue. *See id.* at 4a-8a; *AVX Corp. v. Presidio Components, Inc.*, 923 F.3d 1357, 1365 (Fed. Cir. 2019) (a dissatisfied IPR petitioner must demonstrate “concrete plans for future activity that creates a substantial risk of future infringement or [would] likely cause the patentee to assert a claim of infringement.” (citation omitted)). This test effectively requires an IPR petitioner to walk up to the line of admitting to infringement—itsself a perilous and competitively injurious undertaking. The Federal Circuit has repeatedly applied this rule

to deny parties like GE appellate review of PTO decisions by an Article III court.

As Judge Hughes explained, the Federal Circuit’s “overly rigid and narrow” rule for establishing standing in this context does not just conflict with this Court’s competitor-standing decisions; it effectively resurrects “the ‘reasonable apprehension of imminent suit’ test . . . which the Supreme Court overruled [in *MedImmune, Inc. v. Genentech, Inc.*, 549 U.S. at 132 n.11].” App. 13a (concurrence). Moreover, this case starkly illustrates why the Federal Circuit’s rule is wrong. GE directly competes with United Technologies Corporation (UTC) in a “fiercely competitive market” over the very subject of the patent at issue in this case—commercial aircraft engines. *Id.* at 16a. The PTO’s decision to uphold the patent at issue directly benefits UTC, and harms GE, by limiting GE’s ability to design commercially competitive engines meeting customers’ needs. In fact, GE has already expended time and money to design around the patent. *Id.* at 17a. In any other circuit, those facts would present a straightforward case for competitor standing.

The question whether the Federal Circuit has properly erected this heightened, patent-specific standing requirement is extraordinarily important. The Federal Circuit’s rule frustrates Congress’s express intent of using IPR challenges to weed out invalid and overbroad patents. For purposes of determining standing, it must be assumed that a petitioner’s claim is meritorious. *See Americans for Safe Access v. DEA*, 706 F.3d 438, 443 (D.C. Cir.), *cert. denied*, 571 U.S. 885 (2013). Accordingly, the Federal Circuit’s rule limits Article III oversight of the PTO in circumstances where Congress thought it necessary—

where the PTO has erroneously upheld an overbroad patent. If allowed to stand, the Federal Circuit's rule would erode the vital role of the judiciary in reviewing the legality of administrative actions that inflict real, substantial, and imminent harm on citizens.

The petition should be granted.

STATEMENT OF THE CASE

A. Legal Background

Congress enacted the AIA in 2011, in response to a “growing sense that questionable patents are too easily obtained and are too difficult to challenge.” H.R. Rep. No. 112-98, pt. 1, at 39 (2011). The government had long recognized that “[p]oor patent quality and legal standards and procedures that inadvertently may have anticompetitive effects can . . . hamper competition that otherwise would stimulate innovation.” FTC, *To Promote Innovation: The Proper Balance of Competition and Patent Law and Policy: Executive Summary* 5 (2003). Congress thus created “an adjudicative proceeding,” H.R. Rep. No. 112-98 at 46-47, the IPR process, to permit third parties to challenge patent claims for obviousness or lack of novelty, see 35 U.S.C. § 311(a)-(b).

“[A]ny third party can ask the agency to initiate inter partes review of a patent claim.” *Cuozzo Speed Techs.*, 136 S. Ct. at 2137; see 35 U.S.C. § 311(a). When an IPR petition is filed, the PTO first determines whether to institute review. 35 U.S.C. § 314(a). If review is instituted, the Patent Trial and Appeal Board (Board) then conducts a trial-like proceeding to assess the patentability of the claims at issue. See *id.* § 316; 37 C.F.R. § 42.1 *et seq.* At the end of any IPR instituted by the PTO, the Board must

“issue a final written decision with respect to the patentability of any patent claim challenged by the petitioner.” 35 U.S.C. § 318(a). While the IPR process can result in the elimination of dubious patents, it also carries with it a significant risk for the petitioner: once a final written decision is rendered, the AIA provides that an IPR petitioner “may not assert . . . in a civil action . . . that the [patent] claim is invalid on any ground that the petitioner raised or reasonably could have raised” before the Board. *Id.* § 315(e)(2).

This Court has recognized that the IPR process serves a critical role in “protect[ing] ‘the public’s paramount interest in seeing that patent monopolies are kept within their legitimate scope.’” *Oil States Energy Servs., LLC v. Greene’s Energy Grp., LLC*, 138 S. Ct. 1365, 1374 (2018) (citation omitted). While IPRs come *after* a patent is granted, “[p]atent claims are granted subject to the qualification that the PTO has ‘the authority to reexamine—and perhaps cancel—a patent claim’ in an inter partes review.” *Id.* (citation omitted). As the government has explained, “Congress presumably mandated the use of trial-type procedures in inter partes review because it believed they would increase the accuracy of the Board’s decisions” and “prevent ‘administrative abuses.’” Br. for the Fed. Resp’t 26, *Oil States Energy Servs., LLC v. Greene’s Energy Grp., LLC*, 138 S. Ct. 1365 (2018) (No. 16-712), 2017 WL 4805230 (citations omitted).

Congress also provided a broad right to appellate review of final IPR decisions. Any “party dissatisfied with the final written decision of the [Board] . . . may appeal the decision” to the Federal Circuit, pursuant to 35 U.S.C. §§ 141-144. 35 U.S.C. § 319.

B. Factual Background

GE built and successfully tested America's first jet engine in 1942 under contract with the U.S. Army Air Corps, and has been a worldwide leader in aviation technology ever since. Today, GE (through its operating division GE Aviation) is a global provider of aircraft engines and related systems and services. GE designs, builds, and supplies engines for the majority of commercial aircraft, including Boeing and Airbus airplanes, currently in service around the world.¹

The commercial aircraft engine market is fiercely competitive. Three companies dominate the market: GE; UTC (through its subsidiary Pratt & Whitney); and Rolls-Royce. App. 61a (¶ 4). GE and UTC compete directly against one another, and UTC is GE's biggest competitor in the relevant market. *Id.* Both offer engines customized to work with a customer's aircraft. *Id.* at 61a-63a (¶¶ 5, 8).

Delivering an engine to a customer requires enormous up-front expenditures and commitments: the research, design, testing, development, and certification process for each engine typically takes 8-10 years and costs hundreds of millions, or even billions, of dollars. *Id.* at 62a (¶¶ 6-7). During the design process, a customer approaches GE (or a competitor) with design specifications for a next generation of aircraft. *Id.* at 61a-63a (¶¶ 5, 8). The customer "explain[s] to GE [its] needs and requirements for turbofan engines, to enable GE to provide competitive offerings that will satisfy [its]

¹ See generally GE Aviation, *Aviation History*, <https://www.geaviation.com/company/aviation-history> (last visited Feb. 7, 2020).

requirements.” *Id.* at 70a (¶ 3). GE then performs design work based on those early specifications, in order to meet a prospective date for entry-into-service as much as a decade later. *Id.* at 62a-63a (¶ 8).

Once an engine is selected and certified, an engine maker can expect to receive orders and requests for maintenance for many years, justifying the upfront expenses. *Id.* at 62a (¶ 7). For example, the GE90 turbofan engine used to power the Boeing 777 airliner, which entered service 25 years ago, continues to power 777s today. *Id.* (¶ 6). GE is actively working with customers today to design engines that will fly the next generation of aircraft into the middle of the 21st century if not beyond.

C. This Proceeding

This case arises from UTC’s attempt to gain a competitive advantage in this market by amassing an extensive patent portfolio covering aircraft engines. Over the past decade, UTC has filed thousands of patent applications on aircraft engines; as is not uncommon, applications including overbroad claims have nevertheless been issued by the PTO. App. 63a (¶ 10). One of these is U.S. Patent No. 8,511,605 (’605 patent), which claims a conventional geared turbofan engine in which a turbine drives a fan through a gearbox. *Id.* at 64a (¶¶ 12-13). In the mid-1970s, GE itself had designed a geared engine with all or nearly all of the features described in each challenged claim of UTC’s patent. *Id.* at 65a (¶ 14).

In 2016, GE filed an IPR petition seeking review of the ’605 patent. *Id.* at 2a. GE argued that claims 1-2 and 7-11 of the ’605 patent were either anticipated or rendered obvious by prior art—including references describing GE’s own geared engines built

in the 1970s. *Id.* at 2a-3a. Among other things, a 1979 NASA publication authored by a GE employee disclosed every limitation of independent claim 1. *Id.* at 64a. After the PTO instituted review, UTC disclaimed claims 1-2. *Id.* at 2a. The Board issued a final written decision rejecting GE’s contention that claims 7-11 were invalid for obviousness. *Id.* In doing so, it focused on whether the prior art was capable of meeting *unclaimed* goals, despite this Court’s admonition in *KSR International Co. v. Teleflex Inc.*, 550 U.S. 398, 419 (2007), that obviousness must focus on the claims at issue. *Id.* at 33a-49a.

GE—a “dissatisfied” party, *see* 35 U.S.C. § 319—appealed the PTO’s decision to the Federal Circuit. App. 2a. UTC moved to dismiss the appeal on the ground that GE lacked Article III standing. UTC noted that it had neither sued nor “threatened to sue GE for infringement of the ’605 patent,” and argued that, unless “GE has taken [steps] that may infringe, there is no injury in fact and no standing.” CAFC UTC Mot. to Dismiss 9, ECF No. 30. UTC dismissed the notion that competitive harm could establish standing in the absence of evidence that GE had infringed, or had concrete plans to infringe, the patent. *Id.* at 10-12.

In response, GE submitted two declarations by its Chief IP Counsel and General Counsel for Engineering for GE Aviation, explaining the competitive harm it was currently suffering and would imminently face. *See* App. 60a-73a (Long Decl. & Suppl. Long Decl.).² GE outlined the highly

² GE submitted the first declaration (App. 60a-68a) in response to UTC’s motion to dismiss, and the second (*id.* at 69a-

competitive market for turbofan engines and its fierce competition with UTC. It explained that the existence of the '605 patent “restricts GE’s design choices” for new engines and “forces GE to expend additional research and development money on designs that do not implicate” the patent. *Id.* at 66a (¶ 16). As an example, GE explained that, in recent discussions surrounding an aircraft, Boeing requested that GE “[r]efine” and “[i]nvestigate” a type of engine that would potentially implicate the '605 patent. CAFC Sealed Suppl. Long Decl. ¶ 7 & Ex. I, ECF No. 64 (alterations in original); *see also* App. 72a (Long Suppl. Dec. ¶ 7 (redacted)). In response, GE expended time and money researching and attempting to design an engine that would potentially implicate the '605 patent as well as engines that would not. App. 66a (¶ 16); *id.* at 72a (¶ 7).

Following full briefing and oral argument, the Federal Circuit issued a precedential opinion dismissing GE’s appeal for lack of standing. The court noted that it had “addressed the ‘competitor standing’ doctrine in *AVX Corp. v. Presidio Components, Inc.*, 923 F.3d 1357 (Fed. Cir. 2019).” App. 6a. In *AVX*, the court held that an IPR appellant “lacked Article III standing because it had ‘no present or nonspeculative interest in engaging in conduct’” covered by the challenged patent, even though the appellant actively competed against the patent owner in the relevant market. *Id.* (quoting *AVX*, 923 F.3d at 1363). The Federal Circuit below followed *AVX* and held that it “[saw] no competitive harm to GE sufficient to establish standing to appeal.” *Id.* at 7a. In the court’s

73a) in response to the panel’s request for additional information. App. 2a-4a.

view, the PTO's decision rejecting GE's IPR challenge to the '605 patent "did not change the competitive landscape for commercial airplane engines." *Id.*

The Federal Circuit dismissed all the competitive injuries alleged by GE. As for the "increased research and development costs" that GE has incurred and is likely to incur in trying to design around the '605 patent, the court concluded that GE had failed to provide an adequate "accounting." *Id.* As for the impact on "future" competition, the court pointed to the fact that "UTC has not sued or threatened to sue GE for infringing the '605 patent." *Id.* at 8a. And as for "estoppel under 35 U.S.C. § 315(e)," the court opined that, "[w]here, as here, the appellant does not currently practice the patent claims and the injury is speculative, we have held that the estoppel provision does not amount to an injury in fact." *Id.*

Judge Hughes concurred only in the judgment. *Id.* at 9a. He agreed with the panel that the Federal Circuit's "recent precedent compels holding that [GE] lacks Article III standing here," but he believed that the court's "precedent has developed an overly rigid and narrow standard for Article III standing in the context of appeals from *inter partes* review proceedings." *Id.* He explained that the court's "recent decision in [AVX]," which, in his view, was "incorrectly decided," "takes a patent-specific approach to the doctrine of competitor standing that is out of step with Supreme Court precedent." *Id.* Applying this Court's precedent, he would have held that GE has Article III standing.

As Judge Hughes explained, "[t]he risk of a future infringement suit is not the only way an IPR petitioner can show injury-in-fact." *Id.* at 13a. Instead, he observed, this Court recognizes that a

much broader range of competitive injuries can support standing. *Id.* at 13a-16a. And here, he reasoned, the “costly competitive burden” imposed by UTC’s patent, which “effectively precludes GE from meeting its customer’s design needs without spending additional resources to design around the patent,” constitutes a “concrete and particularized’ harm to GE.” *Id.* at 17a (citation omitted). Judge Hughes added that the AIA’s estoppel provision “underscore[s] the problems with our increasingly narrow approach to Article III standing,” *id.* at 18a, and has an “especially significant impact where the parties are direct competitors,” *id.* at 17a.

The Federal Circuit denied GE’s petition for rehearing en banc. *Id.* at 54a-55a.

REASONS FOR GRANTING THE WRIT

The Federal Circuit has adopted a patent-specific rule for civil litigation that cannot be squared with this Court’s decisions outside the patent context—this time, concerning the requirements for establishing Article III standing in the IPR context. As this Court has long recognized, the baseline requirements for demonstrating Article III standing are central to fulfilling the constitutional role, and duty, of the federal courts to resolve cases and controversies. *See Mata v. Lynch*, 135 S. Ct. 2150, 2156 (2015) (“[W]hen a federal court has jurisdiction, it also has a ‘virtually unflagging obligation . . . to exercise’ that authority.” (alteration in original) (citation omitted)). Those requirements should not fluctuate based on whether a dispute involves a patent or something else.

That includes the requirement for establishing an injury-in-fact—an “invasion of a legally protected interest which is (a) concrete and particularized, and

(b) actual or imminent, not conjectural or hypothetical.” *Lujan v. Defenders of Wildlife*, 504 U.S. 555, 560 (1992) (footnote and quotation marks omitted). While unquestionably important, “[i]njury-in-fact is not Mount Everest.” *Danvers Motor Co. v. Ford Motor Co.*, 432 F.3d 286, 294 (3d Cir. 2005) (Alito, J.). The Court therefore has recognized a broad range of injuries triggering standing under Article III, including competitive and related economic harm. See *Clinton v. City of N.Y.*, 524 U.S. 417, 433 (1998); *Cyzewski v. Jevic Holding Corp.*, 137 S. Ct. 973, 983 (2017) (“For standing purposes, a loss of even a small amount of money is ordinarily an ‘injury.’”).³

The Federal Circuit’s “overly rigid” requirement for establishing Article III standing in the IPR context is “out of step with Supreme Court precedent.” App. 9a (concurrency). The Federal Circuit’s rule also conflicts with decisions of other circuits, which hold that competitive harm itself confers standing, without requiring additional showings. And the upshot is that the Federal Circuit has insulated an important category of agency action from judicial oversight in

³ Courts sometimes differentiate between “competitive harm” (e.g., increased competition or lost business opportunities) and “economic injury” (e.g., the expenditure of additional resources). But as commentators have observed, “the two are simply different sides of the same coin because an agency action that advantages one’s competitor often causes a financial harm to the party.” Matthew Dowd & Jonathan Stroud, *Will Fed. Circ. Consider The Competitor Standing Doctrine?*, Law360 (Dec. 18, 2018), <https://www.law360.com/articles/1110478>. To the extent the two concepts can be distinguished, GE has alleged both competitive and economic injuries (such as the expenditures it has already made in designing around the patent at issue); both naturally fall under the rubric of competitor standing. We refer to the injuries alleged here generally as competitive harm.

direct opposition to the express will of Congress. This Court’s intervention is needed.

I. The Federal Circuit’s Heightened Competitor-Standing Rule Conflicts With Decisions Of Other Circuits

The Federal Circuit’s decision here conflicts with the decisions of other circuits. Whereas in other circuits competitive harm itself may establish Article III standing, in the Federal Circuit an IPR petitioner must make an additional showing—that it has “concrete plans for future activity that creates a substantial risk of future infringement or [would] likely cause the patentee to assert a claim of infringement.” *AVX Corp. v. Presidio Components, Inc.*, 923 F.3d 1357, 1365 (Fed. Cir. 2019) (citation omitted). That circuit conflict warrants certiorari.

A. The Federal Circuit’s Heightened Standing Requirement For IPR Appeals

In *AVX*, the Federal Circuit held that a patent claim could have “a harmful competitive effect” on an IPR challenger only if “the challenger was currently using the claimed features or nonspeculatively planning to do so in competition.” *Id.* *AVX* concerned a challenge to a patent covering a type of capacitor, brought by a rival manufacturer. *Id.* at 1359-60. The parties to the IPR proceeding were frequently adverse in patent litigation, and the IPR petitioner had explained that in the capacitor market, “even the threat of a permanent injunction [based on patent infringement] can dissuade customers from choosing a particular capacitor.” *Id.* at 1360-61. Already, in fact, “at least one customer . . . would not buy one of

AVX's capacitors because of the risk of a future injunction." *Id.* at 1361.

Yet, the Federal Circuit held that the IPR petitioner lacked standing to appeal the PTO's final decision. The Federal Circuit recognized that this Court, as well as the D.C. Circuit, will find standing based on competitive harm where government action "nonspeculatively threaten[s] economic injury to the challenger by the ordinary operation of economic forces." *Id.* at 1364. But the court reasoned that the "government action at issue" in an IPR—"the upholding of specific patent claims"—is "quite different" than the government action challenged in the cases in which other circuits have found standing based on competitive harm. *Id.* at 1365. The court believed that, because government action in the IPR context does not "address prices or introduce new competitors," it does not operate by "ordinary economic forces" to "naturally harm a firm." *Id.*

The AVX court recognized one circumstance where "[a] patent claim *could* have a harmful competitive effect on a would-be challenger" conferring standing—where "the challenger was currently using the claimed features or nonspeculatively planning to do so in competition." *Id.* But the court explained that the Federal Circuit has "repeatedly" denied standing to IPR petitioners seeking to "appeal claim-upholding Board decisions where those petitioners *lacked* 'concrete plans for future activity that creates a substantial risk of future infringement or [would] likely cause the patentee to assert a claim of infringement.'" *Id.* (emphasis added) (quoting *JTEKT Corp. v. GKN Auto. Ltd.*, 898 F.3d 1217, 1221 (Fed.

Cir. 2018), *cert. denied*, 139 S. Ct. 2713 (2019)).⁴ Thus, under *AVX*, “even when . . . parties are direct competitors,” if the IPR “petitioner is not currently engaged in infringing activity and has no concrete plans to do so in the imminent future,” it will be held to lack Article III standing. App. 14a (concurrency).

The Federal Circuit applied the *AVX* rule in holding that GE lacked standing to appeal the IPR decision in this case. *Id.* at 6a-8a. And it has continued to apply that rule in subsequent cases. See *Fisher & Paykel Healthcare Ltd. v. ResMed Ltd.*, 789 F. App’x 877, 878 (Fed. Cir. 2019) (reiterating that a dissatisfied IPR petitioner must demonstrate plans that “create a ‘substantial risk of future infringement,’” and finding that the appellant’s assertion that it “continues to develop products that [the patent owner] may at some future date allege infringe claims of the” challenged patent did not suffice (citation omitted)).

⁴ In addition to *JTEKT*, the *AVX* court cited *Momenta Pharmaceuticals, Inc. v. Bristol-Myers Squibb Co.*, 915 F.3d 764, 770 (Fed. Cir. 2019), and *Phigenix, Inc. v. Immunogen, Inc.*, 845 F.3d 1168, 1173-74 (Fed. Cir. 2017), as cases denying standing where an appellant failed to establish a concrete or substantial risk of infringement. See *AVX*, 923 F.3d at 1365-66. Conversely, the court explained that the Federal Circuit has *found* standing based on “the inevitability of an infringement suit.” *Id.* at 1366-67 (discussing *Altaire Pharmaceuticals, Inc. v. Paragon Biotech, Inc.*, 889 F.3d 1274, 1283 (Fed. Cir.), *remand order modified by stipulation*, 738 F. App’x 1017 (Fed. Cir. 2018); *E.I. DuPont de Nemours & Co. v. Synvina C.V.*, 904 F.3d 996, 1005 (Fed. Cir. 2018)).

B. In Other Circuits, Competitive Harm Alone Confers Standing

By contrast, numerous other circuits have recognized that the sort of competitive harm alleged here confers standing—without requiring any particular showing as to likelihood of future litigation. The First, Second, Third, Seventh, Ninth, and D.C. Circuits all apply simple economic logic to determine the existence of an injury-in-fact; hold that government action creating competitive advantages or burdens in the marketplace is sufficient to support standing; and recognize that the “form of that [competitive] injury may vary.” *Sherley v. Sebelius*, 610 F.3d 69, 72 (D.C. Cir. 2010).⁵

1. The conflict with the D.C. Circuit is especially stark. The D.C. Circuit has applied “[b]asic economic logic” when assessing competitive harm. *American Inst. of Certified Pub. Accountants v. IRS*, 804 F.3d 1193, 1198 (D.C. Cir. 2015). Accordingly, the D.C. Circuit has recognized that “illegal structuring of a competitive environment” is “sufficient to support Article III standing.” *Shays v. FEC*, 414 F.3d 76, 85 (D.C. Cir. 2005). And the court has found standing “when the Government takes a step that benefits [a] rival and therefore injures [a competitor] economically.” *Sherley*, 610 F.3d at 72.

⁵ See also, e.g., *TrafficSchool.com, Inc. v. Edriver Inc.*, 653 F.3d 820, 825-26 (9th Cir. 2011); *Adams v. Watson*, 10 F.3d 915, 922-23 (1st Cir. 1993); *Center for Reproductive Law & Policy v. Bush*, 304 F.3d 183, 197 (2d Cir. 2002); *UPS Worldwide Forwarding, Inc. v. United States Postal Serv.*, 66 F.3d 621 (3d Cir. 1995), *cert. denied*, 516 U.S. 1171 (1996); *Marshall & Ilsley Corp. v. Heimann*, 652 F.2d 685, 692-93 (7th Cir. 1981), *cert. denied*, 455 U.S. 481 (1982).

Two recent cases, in particular, illustrate the gulf between the D.C. Circuit's practical approach to competitor standing and the Federal Circuit's rigid, patent-specific rule. In *Sherley*, the D.C. Circuit addressed the standing of doctors challenging guidelines authorizing increased research grants for embryonic stem cell research. *Id.* at 70-71. The plaintiff doctors performed only *adult* stem cell research, and claimed that the new rule would "result in increased competition for limited federal funding." *Id.* at 71 (citation omitted). The D.C. Circuit found that the doctors had standing, explaining that, because "increased competition [by additional grant applicants] almost surely injures a seller in one form or another, he need not wait until 'allegedly illegal transactions . . . hurt [him] competitively' before challenging the regulatory . . . governmental decision that increases competition." *Id.* at 72 (alterations in original) (citation omitted). The court also emphasized that the mere fact that the doctors would have to "invest more time and resources to craft a successful grant application" established "an actual, here-and-now injury." *Id.* at 74.

The D.C. Circuit stressed that the "form of th[e] injury [triggering standing] may vary." *Id.* at 72. "[F]or example," the court explained, "a seller facing increased competition may lose sales to rivals, or be forced to lower its sale price or to expend more resources to achieve the same sales, all to the detriment of its bottom line." *Id.* Moreover, "[b]ecause increased competition almost surely injures a seller in one form or another, he need not wait until 'allegedly illegal transactions . . . hurt [him] competitively' before challenging the . . . government decision that increases competition."

Id. (alterations in original) (citation omitted); *see id.* at 74 (“Although no one can say exactly how likely the Doctors are to lose funding to [new grant] projects . . . , having been put into competition with those projects, the Doctors face a substantial enough probability to deem the injury to them imminent.”).

The competitive injury in *Sherley* is far less concrete and imminent than the competitive injury here. *Sherley* upheld standing based on the logic that the presence of an unspecified number of additional grant applicants would have some marginal effect on doctors’ chances of securing a grant in the future, and that the doctors would have to spend more time and money to prepare a successful application. By contrast, UTC’s patent has limited GE’s ability to compete in the aircraft engine market by restricting its ability to design and sell a type of engine. And if there were any doubt that the competitive threat here is real, GE—like the plaintiff in *Sherley*—has already suffered “an actual, here-and-now injury” in the form of the “time and resources” it has expended, and will expend, in designing around the patent in order to compete for business. *Id.* at 74.

Mendoza v. Perez is also instructive. There, the D.C. Circuit explained that, to establish standing, a plaintiff need only “demonstrate that it is a direct and current competitor whose bottom line *may* be adversely affected by the challenged government action.” 754 F.3d 1002, 1013 (D.C. Cir. 2014) (emphasis altered). The court thus held that experienced animal herders who had not actually applied for jobs in that industry had standing to challenge regulations that gave “herding operations access to inexpensive foreign labor without protecting U.S. workers.” *Id.* at 1007. Again, the competitive

injury here is far more direct and real. As explained, GE and UTC currently compete in the relevant market and GE has already expended time and resources in seeking to design around the challenged patent in response to customer interest.

The D.C. Circuit is frequently called upon to evaluate the standing of parties challenging agency action that unfairly benefits or burdens competitors or otherwise creates harmful competitive effects. And it has consistently held that “when regulations illegally structure a competitive environment—whether an agency proceeding, a market, or a reelection race—parties defending concrete interests . . . in that environment suffer legal harm under Article III.” *Shays*, 414 F.3d at 87; *see also International Bhd. of Teamsters v. DOT*, 724 F.3d 206, 211-12 (D.C. Cir. 2013) (Kavanaugh, J.) (explaining that under “competitor standing doctrine,” it is understood that “economic actors suffer an injury in fact when agencies lift regulatory restrictions on their competitors or otherwise allow increased competition against them,” because such competitive harm will ultimately result in lower prices or decreased market share (quoting *Sherley*, 610 F.3d at 72)).

2. Other circuits also take a practical, common-sense approach to competitor standing, relying on the “basic law of economics,” rather than rigid rules like the Federal Circuit’s “concrete current or future plans to infringe” test (App. 14a (concurrency)), to determine whether a competitive harm triggers standing. *Cooper v. Texas Alcoholic Beverage Comm’n*, 820 F.3d 730, 738 (5th Cir.), *cert. denied*, 137 S. Ct. 494 (2016); *see also Simmons v. ICC*, 900 F.2d 1023, 1026 (7th Cir. 1990) (“An allegation of competitive injury is sufficient to satisfy the first

prong of the standing test.”), *cert. denied*, 499 U.S. 919 (1991); *Adams v. Watson*, 10 F.3d 915, 922 (1st Cir. 1993) (explaining that “future injury-in-fact is viewed as ‘obvious’” when government action removes competitive burdens on a plaintiff’s rivals, thus “disadvantag[ing] the plaintiff’s competitive position in the relevant marketplace”).

For instance, the Second Circuit recognizes standing where “the government’s allocation of a particular benefit ‘creates an uneven playing field,’” so long as a plaintiff shows “that he personally competes in the same arena with the party to whom the government has bestowed the assertedly illegal benefit.” *Center for Reproductive Law & Policy v. Bush*, 304 F.3d 183, 197 (2d Cir. 2002) (Sotomayor, J.) (quoting *Abortion Rights Mobilization Inc. v. Baker (In re United States Catholic Conference)*, 885 F.2d 1020, 1029 (2d Cir. 1989)). It thus upheld standing where an advocacy organization challenged government action that “bestowed a benefit on plaintiffs’ competitive adversaries.” *Id.* at 197.

Likewise, the First Circuit has recognized that “many cases uphold ‘competitor standing’ based on ‘unadorned allegations’ of latent economic injury.” *Adams*, 10 F.3d at 921 (citation omitted); *id.* at 921 n.13 (collecting cases from the D.C., Second, and Ninth Circuits). Because “basic economic theory . . . posit[s] elemental laws of cause and effect,” that court has explained that parties can rely “on such core economic postulates” to show future economic harm from current competitive changes. *Id.* at 923.

Using the same logic, the Seventh Circuit has found competitor standing where a small bank was being acquired by a larger one, due to the “change in the competitive configuration of [a city’s] banking

community.” *Marshall & Ilsley Corp v. Heimann.*, 652 F.2d 685, 692-93 (7th Cir. 1981), *cert. denied*, 455 U.S. 481 (1982). And the Ninth Circuit has found standing where a competitor deceptively implied that it was a governmental organization in order to garner additional sales, because “[s]ales gained by one [competitor] are thus likely to come at the other’s expense.” *TrafficSchool.com, Inc.*, 653 F.3d at 825-26.

Many of these cases concern situations in which government action introduced new competitors and thus increased competition in the relevant market. But the fact that a patent *excludes* some competitors from engaging in certain market activities, as opposed to *increasing* competition by adding market participants, does not justify the Federal Circuit’s rule. *See AVX*, 923 F.3d at 1367. To the contrary, the PTO’s decision to grant, and then to uphold, an invalid and overbroad patent is functionally “equivalent to agency action that confers an ‘illegal benefit’ on one’s competitor.” Matthew Dowd & Jonathan Stroud, *Will Fed. Circ. Consider The Competitor Standing Doctrine?*, Law360 (Dec. 18, 2018), <https://www.law360.com/articles/1110478>.

As the D.C. Circuit explained in the election context, it does not matter that “challenged rules create neither more nor different rival candidates,” so long as governmental action requires a challenger to “anticipate and respond to a broader range of competitive tactics.” *Shays*, 414 F.3d at 86. The “form of that [competitive] injury may vary,” *Sherley*, 610 F.3d at 72, and competitor standing is triggered not only by “increased competition,” but also by “lost opportunity,” *Mendoza*, 754 F.3d at 1010. Thus, government action that “benefits [a business] rival,” or forces a firm to “expend more resources” to

compete, inflicts an injury-in-fact triggering standing. *Sherley*, 610 F.3d at 72. The decision to uphold an invalid patent is precisely such an action.⁶

Finally, in other circuits standing is particularly obvious where the competitive injury requires a party to incur immediate costs, as happened here. Thus, for example, the First Circuit held that a presidential candidate had standing to challenge regulations permitting corporate sponsorship of presidential debates: the “reasonabl[e] claims” that the candidate was “forced . . . to make significant adjustments to his campaign strategy and use of funds” to keep pace with his rivals conferred standing, even where a precise accounting of that harm was impossible. *Becker v. FEC*, 230 F.3d 381, 386 (1st Cir. 2000), *cert. denied*, 532 U.S. 1007 (2001); *see Sherley*, 610 F.3d at 74 (fact that plaintiffs “will have to invest more time and resources to craft a successful grant application . . . is an actual, here-and-now injury”).

Under that analysis, there is little doubt that GE’s inability to “meet[] its customer’s design needs without spending additional resources to design around the patent” would confer standing. App. 17a. As explained, GE has *already* expended some time and money in attempting to design around the ’605

⁶ That does not mean that the mere existence of a patent is enough to establish standing. IPR challengers seeking to invalidate a patent covering a market in which they do not compete would not be able to assert a competitive injury. Competitive harm would thus not have been implicated in cases such as *Consumer Watchdog v. Wisconsin Alumni Research Foundation*, 753 F.3d 1258 (Fed. Cir. 2014), *cert. denied*, 574 U.S. 1153 (2015). There, the petitioner argued standing based only on an alleged statutory injury.

patent and, as that example alone illustrates, it is likely to do so in the future. *Supra* at 10.

Certiorari is needed to resolve this conflict.

II. The Federal Circuit's Heightened Competitor-Standing Rule Also Conflicts With Decisions Of This Court

A. The Federal Circuit's Rule Conflicts With This Court's Standing Decisions

Other circuits have not come up with this robust approach to competitive harm on their own—they have followed this Court's lead. In *Clinton*, for example, this Court observed that it “routinely recognizes probable economic injury resulting from [governmental actions] that alter competitive conditions as sufficient to satisfy the [Article III ‘injury-in-fact’ requirement].” 524 U.S. at 433 (alterations in original) (quoting 3 K. Davis & R. Pierce, *Administrative Law Treatise* 13-14 (3d ed. 1994)). There, the Court held that farmers' cooperatives had standing to challenge the President's cancellation of a provision entitling certain facilities to tax benefits when selling to a cooperative. The Court explained that the cooperatives had been deprived of statutory “bargaining chips” in negotiations, *id.* at 432, and—following a leading treatise—recognized that it “follows logically that any . . . petitioner who is likely to suffer economic injury as a result of [governmental action] that changes market conditions satisfies [the injury-in-fact] part of the standing test,” *id.* at 433 (last alteration added) (quoting Davis & Pierce 13-14). That is true, the Court held, regardless of whether the cooperatives could show that, if the tax benefit had

remained in effect, they would have succeeded in securing their “end result.” *Id.* at 433 n.22.

Similarly, in *Association of Data Processing Service Organizations, Inc. v. Camp*, the Court held that plaintiffs had standing to challenge an administrative decision that increased competition in plaintiffs’ market by allowing new players to enter, because such competition “*might* entail some future loss of profits.” 397 U.S. 150, 152 (1970) (emphasis added). There, data processing businesses had challenged a decision by the Comptroller of the Currency allowing national banks to make “data processing services available to other banks and to bank customers.” Instead of insisting on proof of an actual loss in business, the Court relied on basic logic to conclude that allowing banks to offer this additional service would impose a competitive burden on firms that already offered the service. *See Investment Co. Inst. v. Camp*, 401 U.S. 617, 620 (1971) (finding standing based on same competitive injury).

The Federal Circuit’s decision in this case cannot be squared with the practical approach to competitor standing consistently followed by this Court. The PTO’s decision operates to exclude GE from a segment of the aircraft engine market and forces GE to expend resources exploring potential alternative offerings to ensure it can compete on a level playing field. The fact that the challenged PTO action neither directly regulates prices nor introduces a new competitor is entirely irrelevant. *See* App. 9a (concurrence) (“[A] Board decision erroneously upholding a competitor’s patent” is not “meaningfully different from the type of government actions held to invoke competitor standing.”). Indeed, a patent is the classic *anti-competition* instrument, granting the holder a

monopoly for its duration. *See WesternGeco LLC v. ION Geophysical Corp.*, 138 S. Ct. 2129, 2139-40 (2018) (Gorsuch, J., dissenting). The PTO’s decision to reject an instituted challenge to the validity of a patent likewise directly impacts competition.

This case sharply illustrates the flaws in the Federal Circuit’s “overly rigid and narrow standard” for establishing competitor standing in the IPR context. App. 9a (concurrence). GE and UTC “are direct competitors in the commercial aircraft turbofan engine market”—indeed, they are two of the three major players in that market. *Id.* at 10a (concurrence); *id.* at 61a (¶ 4). The industry operates on an extremely long lifecycle, in which development must begin a decade or more before an engine will enter into service on a commercial airliner. *Id.* at 62a-63a (¶ 8). Accordingly, “in order to maintain its competitive position in the market,” GE must be able, in discussions with customers, to “consider engine designs which . . . may implicate the” challenged patent. *Id.* at 72a (¶ 9).

In considering designs, GE must therefore either risk ultimately infringing UTC’s overbroad patent years down the road, or expend resources attempting to design around it. As Judge Hughes recognized, the patent thus “effectively precludes GE from meeting its customer’s design needs without spending additional resources to design around the patent.” *Id.* at 17a (concurrence). Both the concreteness and immediacy of GE’s injury are underscored by the fact that it has already expended “time and money to consider engine designs that could potentially implicate the ’605 patent”—at a customer’s specific request. *Id.* at 6a (emphasis omitted); *see also id.* at 71a-72a (¶¶ 5-7). That expenditure of time and

money itself demonstrates that GE is suffering an “actual, here-and-now injury” (*Sherley*, 610 F.3d at 74) that triggers standing under Article III.⁷

Under the principles established by this Court’s decisions, the competitive harm faced by GE readily passes the threshold for an injury-in-fact.

B. The Federal Circuit Disregarded This Court’s Admonitions That Patent Law Is Governed By The Same Basic Principles As Other Areas Of Civil Litigation

The Federal Circuit’s heightened standing rule for IPR appeals also conflicts with this Court’s repeated admonishment that the Federal Circuit should *not* devise special rules for patent litigation.

Outside the IPR context, even the Federal Circuit has applied flexible competitor-standing principles that rely on basic economic logic, rather than impose

⁷ In dismissing these expenditures, the Federal Circuit complained that GE failed to provide an “accounting” for these costs. App. 7a. But here again, its reasoning conflicts with this Court’s own precedent. In *Cyzewski*, this Court admonished that “a loss of even a small amount of money is ordinarily an ‘injury.’” 137 S. Ct. at 983. GE was not required to go further and itemize its costs. *See also Carpenters Indus. Council v. Zinke*, 854 F.3d 1, 5 (D.C. Cir. 2017) (holding that where lumber companies were likely to face reduced timber supplies, “[e]conomic harm to a business clearly constitutes an injury-in-fact” and “the amount is irrelevant,” because “[a] dollar of economic harm is still an injury-in-fact for standing purposes”); *Ecosystem Inv. Partners v. Crosby Dredging, L.L.C.*, 729 F. App’x 287, 293 (5th Cir. 2018) (holding that “delay in recovering [a plaintiff’s] investment and the lingering uncertainty that it will ever be recouped constitutes economic harm. Even if this harm is small, ‘[f]or standing purposes, a loss of even a small amount of money is ordinarily an “injury”” (alteration in original) (quoting *Cyzewski*, 137 S. Ct. at 983)).

rigid rules about the particular types of harms that trigger standing. In *Canadian Lumber Trade Alliance v. United States*, for example, the Canadian Wheat Board challenged the distribution of collected duties to U.S. wheat producers. 517 F.3d 1319 (Fed. Cir. 2008), *cert. denied*, 555 U.S. 819 (2008). The Federal Circuit held that an injury-in-fact could be inferred without requiring a further showing that the distribution would certainly lower prices or reduce market share, because “it is *presumed* (i.e., without affirmative findings of fact) that a boon to some market participants is a detriment to their competitors.” *Id.* at 1334. The Federal Circuit has thus created a patent-specific rule for constitutional standing—distinct even from the rule applicable to non-patent cases *within that circuit*.

This Court has repeatedly stressed, however, that “[p]atent law is governed by the same common-law principles, methods of statutory interpretation, and procedural rules as other areas of civil litigation.” *SCA Hygiene Prods. Aktiebolag*, 137 S. Ct. at 964 (alteration in original); *id.* at 963-64 (rejecting Federal Circuit’s patent-specific rule). The Court therefore has frequently intervened when the Federal Circuit has erroneously devised patent-specific rules. *See, e.g., id.*; *MedImmune, Inc. v. Genentech, Inc.*, 549 U.S. 118, 132 & n.11 (2007); *Holmes Grp., Inc. v. Vornado Air Circulation Sys., Inc.*, 535 U.S. 826, 827-34 (2002); *eBay Inc. v. MercExchange, L.L.C.*, 547 U.S. 388, 391-93 (2006). Here again, the Federal Circuit’s departure from the baseline rule for civil litigation, and creation of a patent-specific rule for standing, warrants this Court’s intervention.

In fact, not only has the Federal Circuit once again taken a patent-specific approach to generally

applicable doctrine, but it has done so in a way that this Court has *already* rejected. In *MedImmune*, the Court explained that the Federal Circuit had erred in creating a patent-specific test for Article III standing under the Declaratory Judgment Act. 549 U.S. at 132 n.11. Under that erroneous test, a plaintiff could demonstrate injury-in-fact only by showing a “reasonable apprehension of suit.” *Id.* (citation omitted); *see also ABB Inc. v. Cooper Indus., LLC*, 635 F.3d 1345, 1348 (Fed. Cir. 2011) (recognizing that this Court rejected the requirement of a “reasonable apprehension of imminent suit”). As Judge Hughes explained, the Federal Circuit’s rule here “conflate[s] the injury-in-fact analysis with the ‘reasonable apprehension of imminent suit’ test for declaratory judgment jurisdiction.” App. 13a (concurrency).

The Federal Circuit’s roundabout resurrection of its discredited, “reasonable apprehension of imminent suit” test as a barrier to standing in the IPR context underscores the need for this Court’s review.

C. The Federal Circuit’s Heightened Standing Requirement Is Particularly Inappropriate In The IPR Context

The Federal Circuit’s imposition of a heightened standing requirement is especially problematic in the context of the underlying statutory scheme. The Federal Circuit’s decision frustrates Congress’s clear intent to grant broad rights to challenge PTO decisions and access appellate review; disregards the additional risk of harm imposed by the AIA’s estoppel provision; and flies in the face of historical practice.

Congress unambiguously sought to broadly define the universe of those who could seek IPR and subsequently challenge the PTO’s final written

decisions before an Article III court. Congress gave any person the right to invoke the IPR process, regardless of whether the person had any connection to the patent at issue. 35 U.S.C. § 311(a); *see also id.* § 315(c). Congress also appreciated that appellate review of the PTO's determinations by an Article III court would be critical to the healthy functioning of this regime. It thus allowed any "dissatisfied" party the right to appeal a PTO determination. *Id.* § 319; *see supra* at 5-6. While Congress cannot override Article III, its clear intent to allow any "dissatisfied" party to appeal strongly counsels against *heightening* the burden for establishing Article III injury-in-fact.

The Federal Circuit's rule ignores the unique role of Congress in defining injuries-in-fact. *See Spokeo, Inc. v. Robins*, 136 S. Ct. 1540, 1549 (2016) ("the judgment of Congress play[s] [an] important role[]" in identifying injuries-in-fact). By allowing any "party dissatisfied with [a] final written decision" to appeal, 35 U.S.C. § 319, Congress demonstrated an intent to expand the right to access federal courts as broadly as the Constitution permits. Imposition of a heightened standing rule is particularly inappropriate "where Congress has provided IPR petitioners [this] procedural right of appeal." App. 14a (concurrency).

Moreover, the competitive harm faced by GE is magnified by the AIA's estoppel provision. 35 U.S.C. § 315(e). As Judge Hughes observed, "the effects of that estoppel have especially significant impact where the parties are direct competitors." App. 17a (concurrency). In a long-lifecycle industry such as the commercial aircraft engine business, competitors may be precluded from mounting a challenge to an overbroad patent many years down the road—thus making "potential infringement litigation

significantly more impactful on GE's future design choices." *Id.* at 18a (conurrence). The PTO's decision rejecting an IPR challenge therefore grants a competitor an added advantage (on top of the patent), which is absent until or unless the PTO rejects an IPR challenge in a final Board decision. *Cf. Deposit Guar. Nat'l Bank v. Roper*, 445 U.S. 326, 334-37 (1980) (collateral estoppel effect of decision concerning the validity of a patent in "unspecified future litigation" may create "personal stake" conferring Article III standing; discussing *Electrical Fittings Corp. v. Thomas & Betts Co.*, 307 U.S. 241, 241-43 (1939)).

Historical practice also weighs against ratcheting up the standing requirement in this context. In fact, if a patent-specific approach to Article III standing were ever appropriate, history would favor *relaxing* the showing required. Historical tradition, going back to the English Court of Chancery, permitted parties to challenge improperly issued patents through a writ of scire facias even if they suffered no specific, patent-related injury. *See* W.M. Hindmarch, *A Treatise on the Law Relative to Patent Privileges for the Sole Use of Inventions* 235 (1847); *see also* Richard Godson, *A Practical Treatise on the Law of Patents for Inventions and of Copyright* 197 (1832) ("All persons are injured by the existence of an illegal patent for an invention, and every one is therefore at liberty to petition . . . to have it cancelled."). That tradition bears on the constitutional standing inquiry and militates in favor of recognizing standing in this case. *See Vermont Agency of Natural Res. v. United States ex rel. Stevens*, 529 U.S. 765, 774 (2000). Moreover, this Court recently affirmed that the PTO, in issuing a patent, "take[s] from the public rights of immense value, and bestow[s] them upon the patentee." *Oil States Energy*

Servs., LLC v. Greene's Energy Grp., LLC, 138 S. Ct. 1365, 1373 (2018) (alterations in original) (citation omitted). If GE—a direct competitor of UTC in the relevant market—cannot challenge that taking of a public right, it is unclear who could do so.

III. The Question Presented Is Exceptionally Important And Warrants Review

The scope of Article III standing is central to the role of the Judiciary and, as relevant here, the ability of citizens to challenge government action. See *DaimlerChrysler Corp. v. Cuno*, 547 U.S. 332, 341-43 (2006). The injury-in-fact required to establish competitor standing, in particular, is an issue of recurring and unquestioned importance.

Judicial recognition of competitive injury plays a crucial role in ensuring that the federal courts are available to check government action that unlawfully impacts competition among market participants. The D.C. Circuit's robust competitor-standing rule, for example, has facilitated judicial review of a broad array of administrative decisions by parties facing competitive harm from those decisions. See, e.g., *Sherley*, 610 F.3d at 72-73 (finding standing to challenge new guidelines on stem cell research because of impact on competition).

The application of the injury-in-fact requirement is also unquestionably important in the IPR context in particular. In enacting the AIA, Congress wished to subject the PTO's determinations to greater oversight by allowing private parties to challenge overbroad patents. As one Congress member noted, "patents may discourage competition," and invalid patents "severely restrict[]" the "flow of ideas and capital." *Patent Quality Improvement: Post-Grant*

Opposition: Hearing before the Subcomm. on Courts, the Internet, and Intellectual Prop. of the H. Comm. on the Judiciary, 108th Cong. 49 (2004) (statement of Rep. John Conyers, Jr.). Likewise, Congress appreciated that “a more efficient and streamlined patent system” would have pro-competitive effects by “improv[ing] patent quality and limit[ing] . . . litigation costs,” H.R. Rep. No. 112-98 at 40.

By insulating PTO decisions upholding patent claims from judicial review, the Federal Circuit’s heightened standing rule restricts precisely the outside scrutiny of the PTO’s patent determinations that Congress intended to increase. The rule thus frustrates Congress’s efforts to permit more efficient challenges to patents that restrict innovation. Worse, it creates an asymmetry that favors invalid patents. A patent-holder whose patent is invalidated through the IPR process will always have standing to seek judicial review. But an unsuccessful IPR challenger will lack standing unless he can demonstrate a concrete plan to infringe. That result places a thumb on the scale *against* the exact public interest that the IPR process was designed to protect.

The stark facts of this case present an excellent vehicle to review the Federal Circuit’s heightened standing rule. As Judge Hughes explained, the record here shows real and imminent competitive harm in a “fiercely competitive market.” App. 16a (concurrence). Only by applying the Federal Circuit’s heightened requirement did the court deny standing. This case therefore offers the Court an ideal opportunity to address the question presented.

CONCLUSION

The petition for a writ of certiorari should be granted.

Respectfully submitted,

SHAY DVORETZKY
AMANDA K. RICE
JONES DAY
51 Louisiana Ave., NW
Washington, DC 20001
(202) 879-3939

GREGORY G. GARRE
Counsel of Record
ROMAN MARTINEZ
TYCE R. WALTERS
LATHAM & WATKINS LLP
555 Eleventh Street, NW
Suite 1000
Washington, DC 20004
(202) 637-2207
gregory.garre@lw.com

Counsel for Petitioner

February 12, 2020

APPENDIX

TABLE OF CONTENTS

	Page
Opinion of the United States Court of Appeals for the Federal Circuit, <i>General Electric Co. v. United Technologies Corp.</i> , 928 F.3d 1349 (Fed. Cir. 2019)	1a
Final Written Decision of the United States Patent and Trademark Office Before the Patent Trial and Appeal Board, <i>General Electric Co. v. United Technologies Corp.</i> , Case IPR2016-00531 (P.T.O. June 26, 2017).....	19a
Order of the United States Court of Appeals for the Federal Circuit Denying Petition for Rehearing En Banc, <i>General Electric Co. v. United Technologies Corp.</i> , No. 2017-2497 (Fed. Cir. Oct. 15, 2019)	54a
U.S. Const. art. III, § 2.....	56a
35 U.S.C. § 311	57a
35 U.S.C. § 315(e).....	58a
35 U.S.C. § 319	59a
Declaration of Alexander E. Long in Support of General Electric Company’s Opposition to Appellee’s Motion to Dismiss, <i>General Electric Co. v. United Technologies Corp.</i> , No. 2017-2497 (Fed. Cir. Jan. 16, 2018), ECF No. 36 (without exhibits)	60a

TABLE OF CONTENTS—Continued

	Page
Supplemental Declaration of Alexander E. Long in Support of General Electric Company’s Standing, <i>General Electric Co. v. United Technologies Corp.</i> , No. 2017-2497 (Fed. Cir. Nov. 28, 2018) (redacted), ECF No. 63 (without exhibit)	69a

UNITED STATES COURT OF APPEALS,
FEDERAL CIRCUIT

**GENERAL ELECTRIC COMPANY,
Appellant**

v.

**UNITED TECHNOLOGIES CORPORATION,
Appellee**

2017-2497

Decided: July 10, 2019

928 F.3d 1349

OPINION

Before Reyna, Taranto, and Hughes, Circuit Judges.

Concurring opinion filed by Circuit Judge Hughes.
Reyna, Circuit Judge.

General Electric Company petitioned the United States Patent Trial and Appeal Board for *inter partes* review of U.S. Patent No. 8,511,605. United Technologies Corporation is the assignee of the patent. The Board found the claims not obvious in view of the prior art. General Electric appeals. For the reasons discussed below, we hold that General Electric lacks Article III standing and accordingly, we dismiss the appeal.

BACKGROUND

Appellee United Technologies Corporation (“UTC”) is the assignee of U.S. Patent No. 8,511,605 (“the ’605 patent”). The ’605 patent is generally directed to a gas turbine engine having a gear train driven by a spool with a low stage count low pressure turbine. ’605 patent, Abstract. This particular gas

turbine engine is designed for use in airplanes and has an axially movable variable area fan nozzle.

On January 29, 2016, General Electric Company (“GE”) filed a petition for *inter partes* review (“IPR”) challenging claims 1 and 2 of the ’605 patent on grounds of anticipation and claims 7–11 of the ’605 patent on grounds of obviousness. After institution, UTC disclaimed claims 1 and 2, leaving only claims 7–11 at issue. On June 26, 2017, the United States Patent Trial and Appeal Board (“Board”) issued a Final Written Decision concluding that the preponderance of the evidence did not show claims 7–11 of the ’605 patent to be unpatentable for obviousness. GE timely appealed to this court.

On December 29, 2017, UTC moved to dismiss GE’s appeal for lack of standing. UTC asserted that GE lacked standing because it failed to demonstrate a sufficient injury in fact. In support, UTC pointed to this court’s decisions holding that an appellant does not automatically possess standing to appeal an adverse Board decision by virtue of serving its petitions in the challenged IPR. GE submitted a response on January 16, 2018, including the Declaration of Alexander E. Long, GE’s Chief IP Counsel and General Counsel of Engineering for GE Aviation (“First Long Declaration”). Mr. Long explained that the commercial aircraft engine business operates on a long life-cycle and that airplane engines are designed to meet certain specifications for certain aircraft. Because the design of aircraft engines can take eight years or more, GE develops new engines based on old designs. Mr. Long stated that, in the 1970s, GE developed a geared turbofan engine with a variable area fan nozzle for NASA. GE asserted that the ’605 patent impedes its

ability to use its 1970s geared-fan engine design as a basis for developing and marketing future geared turbofan engine designs with a variable area fan nozzle, thereby limiting the scope of GE's engine designs and its ability to compete in a highly regulated industry. Mr. Long also declared that designing around the '605 patent restricts GE's design choices and forced GE to incur additional research and development expenses.

We denied UTC's motion without addressing the merits and ordered UTC to brief the issue in its responsive appellate brief. The parties subsequently briefed the standing issue. GE argued that the injuries it suffered include statutory estoppel, economic loss, future threat of litigation, and competitive harm. GE relied on the First Long Declaration as evidence to show its injuries. UTC argued that GE suffered no injury in fact because: (1) UTC has not sued or threatened to sue GE for infringement of the '605 patent; (2) GE does not offer evidence of a concrete and particularized economic injury because it has not developed an engine that implicates claims 7–11 of the '605 patent; and (3) statutory estoppel and the competitive standing doctrine do not apply to GE.

We heard oral argument on November 7, 2018. Much of oral argument focused on whether GE had constitutional standing to appeal and whether general statements made in the First Long Declaration were sufficient to establish standing. We subsequently ordered GE to supplement the First Long Declaration and submit any additional declarations that would provide greater specificity regarding the asserted injury GE contends provides

sufficient standing to appeal in this matter. We provided UTC with an opportunity to respond.

Each party filed its supplemental submission. GE filed an additional declaration from Mr. Long on November 28, 2018 (“Second Long Declaration”). In his second declaration, Mr. Long stated that Boeing requested information from GE and several of its competitors for engine designs for future Boeing aircrafts. Mr. Long also noted that Boeing requested information regarding designs for both geared-fan engines and direct-drive engines.

In response to Boeing’s request, GE researched a geared-fan engine design that “would potentially implicate [UTC’s] 605 Patent.” Second Long Decl. ¶ 5. GE asserts it “expended time and money researching and further developing” this technology for the potential business opportunity with Boeing. *Id.* ¶ 7. Ultimately, GE chose not to submit to Boeing a geared-fan engine design and instead submitted a design for a direct-drive engine of the type used in GE’s current engine designs. The record does not indicate why GE submitted a direct-drive engine design instead of a geared-fan engine design. Nor does Mr. Long state whether GE lost this particular bid. He contends only that to maintain GE’s competitive position, it needs to be able to meet customer needs with a geared-fan engine design that may implicate the ’605 patent.

DISCUSSION

Not every party to an IPR will have Article III standing to appeal a final written decision of the Board. *See Phigenix, Inc. v. Immunogen, Inc.*, 845 F.3d 1168, 1172 (Fed. Cir. 2017) (citing *Cuozzo Speed Techs., LLC v. Lee*, — U.S. —, 136 S. Ct. 2131,

2143–44, 195 L.Ed.2d 423 (2016)). To establish standing, an appellant must have suffered an injury in fact that has a nexus to the challenged conduct and that can be ameliorated by the court. *Id.* at 1171 (citing *Spokeo, Inc. v. Robins*, — U.S. —, 136 S. Ct. 1540, 1545, 194 L.Ed.2d 635 (2016)). The injury in fact must be “concrete and particularized,” not merely “conjectural or hypothetical.” *JTEKT Corp. v. GKN Auto. Ltd.*, 898 F.3d 1217, 1220 (Fed. Cir. 2018) (emphasis omitted) (first quoting *Spokeo*, 136 S. Ct. at 1545, and then quoting *Lujan v. Defs. of Wildlife*, 504 U.S. 555, 560, 112 S.Ct. 2130, 119 L.Ed.2d 351 (1992)).

GE has the burden of showing that it suffered an injury in fact sufficient to confer Article III standing to appeal. *See DaimlerChrysler Corp. v. Cuno*, 547 U.S. 332, 342, 126 S.Ct. 1854, 164 L.Ed.2d 589 (2006). It is undisputed that GE did not establish before the Board that it had standing to appeal the Board’s Final Written Decision. *See JTEKT*, 898 F.3d at 1220. Therefore, GE must create a record in this court with the “requisite proof of an injury in fact” sufficient to show that it has standing to appeal. *Id.* (quoting *Phigenix*, 845 F.3d at 1171–72). As a result, GE has submitted two declarations from Mr. Long and has proffered three theories of harm to support standing: (1) competitive harm; (2) economic losses; and (3) estoppel under 35 U.S.C. § 315(e). For the reasons stated below, we reject GE’s arguments.

GE’s purported competitive injuries are too speculative to support constitutional standing. *See Phigenix*, 845 F.3d at 1171 (stating that the injury must be real or imminent). Mr. Long’s declarations are the only evidence of standing before the court, and neither shows a concrete and imminent injury to GE

related to the '605 patent. Mr. Long does not assert that GE lost bids to customers because it could offer only a direct-drive engine design. Nor does Mr. Long attest that GE submitted a direct-drive engine design to Boeing *because* of the '605 patent. Mr. Long contends only that GE expended some unspecified amount of time and money to consider engine designs that could *potentially* implicate the '605 patent. Boeing may have asked for information regarding a possible geared-fan engine design, but there is no evidence that Boeing demanded or required an engine covered by claims 7–11 of the '605 patent, and there is no indication that GE lost the Boeing bid. The evidence shows that GE submitted to Boeing a direct-drive engine design, but there is no indication as to why it opted not to submit a geared-fan engine design. There is also no evidence that GE lost business or lost opportunities because it could not deliver a geared-fan engine covered by the upheld claims or any evidence that prospective bids require geared-fan engine designs. GE asserts only speculative harm untethered to the '605 patent. Without a real, particularized injury, GE lacks standing to appeal the IPR decision.

We recently addressed the “competitor standing” doctrine in *AVX Corp. v. Presidio Components, Inc.*, 923 F.3d 1357 (Fed. Cir. 2019). There, we concluded that the appellant lacked Article III standing because it had “no present or nonspeculative interest in engaging in conduct even arguably covered by the patent claims at issue.” *Id.* at 1363. We explained that competitor standing has been found when government action alters competitive conditions. *Id.* at 1364 (citing *Clinton v. City of New York*, 524 U.S. 417, 433, 118 S.Ct. 2091, 141 L.Ed.2d 393 (1998)). In

those circumstances, the government “provides benefits to an existing competitor or expands the number of entrants in the petitioner’s market, not an agency action that is, at most, the first step in the direction of future competition.” *Id.* at 1364 (quoting *New World Radio, Inc. v. FCC*, 294 F.3d 164, 172 (D.C. Cir. 2002)).

For the competitor standing doctrine to apply, the government action must change the competitive landscape by, for example, creating new benefits to competitors. Put another way, the government action must alter the status quo of the field of competition. Here, the Board’s upholding of claims 7–11 of the ’605 patent did not change the competitive landscape for commercial airplane engines. *See id.* (“The government action is the upholding of specific patent claims, which do not address prices or introduce new competitors, but rather give exclusivity rights over precisely defined product features.”). Therefore, we see no competitive harm to GE sufficient to establish standing to appeal.

We similarly reject GE’s economic losses argument. GE contends that it has been injured by increased research and development costs sustained by attempts to design engines that could implicate the ’605 patent and engines that do not implicate the ’605 patent. Yet, GE provides no further details. It fails to provide an accounting for the additional research and development costs expended to design around the ’605 patent. It provides no evidence that GE actually designed a geared-fan engine or that these research and development costs are tied to a demand by Boeing for a geared-fan engine. The only evidence that GE actually designed a geared-fan engine is the engine that it designed in the 1970s. Any economic loss

deriving from the 1970s engine is not an imminent injury. *See Lujan*, 504 U.S. at 560, 112 S.Ct. 2130 (stating that injury in fact must be actual or imminent). Aside from a broad claim of research and development expenditures, GE has provided no evidence that these expenses were caused by the '605 patent. *See id.* (requiring “a causal connection between the injury and the conduct complained of”). Therefore, GE’s broad claim of economic loss is insufficient to confer standing.

There is also no evidence that GE is in the process of designing an engine covered by claims 7–11 of the '605 patent. Nor has GE demonstrated that it has definite plans to use the claimed features of the '605 patent in the airplane engine market. *See JTEKT*, 898 F.3d at 1221 (holding appellant lacked standing because it had not established that it had “concrete plans for future activity that creates a substantial risk of future infringement”). UTC has not sued or threatened to sue GE for infringing the '605 patent. Appellee Br. 36. Therefore, GE’s future harm argument fails.

GE also contends that estoppel under 35 U.S.C. § 315(e) creates injury in fact for standing purposes. We have previously rejected the estoppel argument as a basis for Article III standing. Where, as here, the appellant does not currently practice the patent claims and the injury is speculative, we have held that the estoppel provision does not amount to an injury in fact. *See, e.g., AVX Corp.*, 923 F.3d at 1362–63; *Phigenix*, 845 F.3d at 1175–76; *Consumer Watchdog v. Wis. Alumni Research Found.*, 753 F.3d 1258, 1262 (Fed. Cir. 2014). We see no need to reach a different conclusion on this record.

CONCLUSION

We have considered GE's remaining arguments and find them unpersuasive. We hold that GE lacks Article III standing to appeal the Board's Final Written Decision and therefore dismiss the appeal.

DISMISSED

COSTS

No costs.

Hughes, Circuit Judge, concurring.

Because our recent precedent compels holding that General Electric Company lacks Article III standing here, I concur in the judgment. I write separately because I believe that precedent has developed an overly rigid and narrow standard for Article III standing in the context of appeals from *inter partes* review proceedings.

Our recent decision in *AVX Corp. v. Presidio Components, Inc.*, 923 F.3d 1357 (Fed. Cir. 2019), which I believe was incorrectly decided, takes a patent-specific approach to the doctrine of competitor standing that is out of step with Supreme Court precedent. The Court has repeatedly held that government actions altering the competitive landscape of a market cause competitors probable economic injury sufficient for Article III standing. And I do not believe that a Board decision erroneously upholding a competitor's patent in an IPR is meaningfully different from the type of government actions held to invoke competitor standing in those cases. Thus, absent our holding in *AVX Corp.*, I would conclude that GE possesses Article III standing in this appeal.

The parties here are direct competitors in the commercial aircraft turbofan engine market. GE, both itself and through joint ventures, “designs, tests, certifies, manufactures, and supplies aircraft engines” for major airplane manufacturers, or “airframers,” such as Boeing and Airbus. Decl. of Alexander E. Long 2 ¶ 3, ECF No. 36. During the design process, “airframers explain to GE their needs and requirements for turbofan engines, to enable GE to provide competitive offerings that will satisfy the airframers’ requirements.” Suppl. Decl. of Alexander E. Long 2 ¶ 3, ECF No. 64.

Due to the safety and regulatory requirements of the turbofan engine market, “designing, developing, testing, and certifying a new aircraft engine can take eight to ten years or longer.” Long Decl. 3 ¶ 6. And “[t]here is enormous up-front investment required.” Long Decl. 4 ¶ 7. Accordingly, “new aircraft engine design work necessarily begins years before there is any commercial sale or offer for sale of the final engine.” Long Decl. 4 ¶ 8.

According to GE, competition in the aircraft engine market is fierce, and the market is dominated by three major players: GE, Universal Technologies Corporation, and Rolls-Royce. GE petitioned for IPR of a patent owned by UTC. That patent is directed to a turbofan engine design – the very type of technology over which GE and UTC fiercely compete. The Board decided that GE failed to show that the challenged claims were unpatentable, and GE appealed that decision to this Court.

UTC filed a motion to dismiss the appeal, arguing that GE lacks Article III standing because GE does

not produce or plan to produce an engine that would infringe its patent. Relying on precedent of both this Court and the Supreme Court, GE argued that the Board's decision to uphold UT's patent caused GE a concrete competitive injury sufficient to satisfy Article III standing.

II

The sole issue with respect to standing in this case is whether GE has shown that it has suffered an injury-in-fact. An injury-in-fact requires a party to establish “an invasion of a legally protected interest which is (a) concrete and particularized, and (b) actual or imminent, not conjectural or hypothetical.” *Lujan v. Defs. of Wildlife*, 504 U.S. 555, 560, 112 S.Ct. 2130, 119 L.Ed.2d 351 (1992) (internal quotation marks and citations omitted). This requirement “ensure[s] that the plaintiffs have a stake in the fight and will therefore diligently prosecute the case . . . while, at the same time, ensuring that the claim is not abstract or conjectural so that resolution by the judiciary is both manageable and proper.” *Canadian Lumber Trade All. v. United States*, 517 F.3d 1319, 1333 (Fed. Cir. 2008) (internal quotation marks omitted); see also *Massachusetts v. E.P.A.*, 549 U.S. 497, 517, 127 S.Ct. 1438, 167 L.Ed.2d 248 (2007) (“At bottom, ‘the gist of the question of standing’ is whether petitioners have ‘such a personal stake in the outcome of the controversy as to assure that concrete adverseness which sharpens the presentation of issues upon which the court so largely depends for illumination.’” (quoting *Baker v. Carr*, 369 U.S. 186, 204, 82 S.Ct. 691, 7 L.Ed.2d 663 (1962))). But “[i]njury-in-fact is not Mount Everest.” *Canadian Lumber*, 517 F.3d at 1333 (quoting *Danvers Motor Co.*

v. Ford Motor Co., 432 F.3d 286, 294 (3d Cir. 2005)); accord *Bowman v. Wilson*, 672 F.2d 1145, 1151 (3d Cir. 1982) (“The contours of the injury-in-fact requirement, while not precisely defined, are very generous.”).

Many of our recent cases dealing with injury-in-fact in IPR appeals have focused on the appellant/petitioner’s likelihood of facing a future infringement suit. See *JTEKT Corp. v. GKN Auto. LTD.*, 898 F.3d 1217, 1220 (Fed. Cir. 2018) (noting that “typically in order to demonstrate the requisite injury in an IPR appeal, the appellant/petitioner must show that it is engaged or will likely engage ‘in an[] activity that would give rise to a possible infringement suit,’ . . . or has contractual rights that are affected by a determination of patent validity” (quoting *Consumer Watchdog v. Wis. Alumni Research Found.*, 753 F.3d 1258, 1262 (Fed. Cir. 2014))); see also *Momenta Pharm., Inc. v. Bristol-Myers Squibb Co.*, 915 F.3d 764, 769–70 (Fed. Cir. 2019) (holding that an IPR petitioner lacked standing because it had abandoned its plans for developing a potentially infringing product, so it no longer faced a potential infringement suit); *E.I. Dupont de Nemours & Co. v. Synvina C.V.*, 904 F.3d 996, 1004 (Fed. Cir. 2018) (holding that an IPR petitioner had suffered an injury in fact because it “currently operates a plant capable of infringing” the challenged patent); *Phigenix, Inc. v. Immunogen, Inc.*, 845 F.3d 1168, 1173–74 (Fed. Cir. 2017) (noting that appellant “does not contend that it faces risk of infringing the [challenged] patent, that it is an actual or prospective licensee of the patent, or that it otherwise plans to take any action that would implicate the patent”); *Consumer Watchdog*, 753 F.3d at 1262 (noting that

the appellant/petitioner “is not engaged in any activity that would give rise to a possible infringement suit”). But these cases do not suggest that the *only* means for an IPR petitioner to establish injury-in-fact is to show a reasonable likelihood of an imminent infringement suit. Such a reading would conflate the injury-in-fact analysis with the “reasonable apprehension of imminent suit” test for declaratory judgment jurisdiction, which the Supreme Court overruled. *See MedImmune, Inc. v. Genentech, Inc.*, 549 U.S. 118, 132 n. 11, 127 S.Ct. 764, 166 L.Ed.2d 604 (2007) (noting that the “reasonable apprehension of suit” test conflicts with Supreme Court precedent); *see also ABB Inc. v. Cooper Indus., LLC*, 635 F.3d 1345, 1348 (Fed. Cir. 2011) (recognizing that *MedImmune* rejected the requirement of a “reasonable apprehension of imminent suit” to establish declaratory judgment jurisdiction).

The risk of a future infringement suit is not the only way an IPR petitioner can show injury-in-fact. “The [Supreme Court] routinely recognizes probable economic injury resulting from [government actions] that alter competitive conditions as sufficient to satisfy the [Article III injury-in-fact requirement].” 3 K. Davis & R. Pierce, *Administrative Law Treatise* 13–14 (3d ed. 1994); *see also Clinton v. City of New York*, 524 U.S. 417, 433, 118 S.Ct. 2091, 141 L.Ed.2d 393 (1998) (citing David & Pierce, *supra*, at 13–14). This Court’s recent decision in *AVX Corp.* addressed the competitor standing doctrine in IPR appeals. We held that a patent could cause an IPR petitioner competitive harm if the petitioner “was currently using the claimed features [of the challenged patent] or nonspeculatively planning to do so in competition.”

AVX Corp., 923 F.3d at 1365. But if the petitioner is not currently engaged in infringing activity and has no concrete plans to do so in the imminent future, we held that the Board’s decision to uphold a challenged patent does not invoke the competitor standing doctrine. *Id.*

Thus, even when the parties are direct competitors, our cases require an unsuccessful IPR appellant/petitioner to show concrete current or future plans to infringe the challenged patent. I do not believe that Article III requires such a showing, particularly where Congress has provided IPR petitioners a procedural right of appeal. *See* 35 U.S.C. § 141; *see also Consumer Watchdog*, 753 F.3d at 1261 (recognizing that “where Congress has accorded a procedural right to a litigant, such as the right to appeal an administrative decision, certain requirements of standing—namely immediacy and redressability, as well as prudential aspects that are not part of Article III—may be relaxed”).

AVX Corp. found that the “government action at issue [in IPR] is quite different” from the government action in other cases applying competitor standing. *AVX Corp.*, 923 F.3d at 1365. According to *AVX Corp.*, the “feature-specific exclusivity right [of a patent] does not, by the operation of ordinary economic forces, naturally harm a firm just because it is a competitor in the same market as the beneficiary of the government action (the patentee).” *Id.* This analysis sets patents apart from other applications of competitor standing on the basis that a patent’s exclusivity right is different than other interests. The Supreme Court, however, has made clear that “[p]atent law is governed by the same common-law principles, methods of statutory interpretation, and

procedural rules as other areas of civil litigation.” *SCA Hygiene Prods. Aktiebolag v. First Quality Baby Prods., LLC*, — U.S. —, 137 S. Ct. 954, 964, 197 L.Ed.2d 292 (2017) (internal quotation marks omitted).

Our patent-specific treatment of competitor standing is out of step with its application in other areas. The Supreme Court has repeatedly found standing where government action subjects the plaintiff to increased competition because of the probable economic injury that accompanies it. See *Clinton*, 524 U.S. at 433, 118 S.Ct. 2091; *Ass’n of Data Processing Serv. Orgs., Inc.*, 397 U.S. 150, 152, 90 S.Ct. 827, 25 L.Ed.2d 184 (1970); *Inv. Co. Inst. v. Camp*, 401 U.S. 617, 620, 91 S.Ct. 1091, 28 L.Ed.2d 367 (1971); accord *Canadian Lumber*, 517 F.3d at 1334; *La. Energy & Power Auth. v. FERC*, 141 F.3d 364, 367 (D.C. Cir. 1998). In *Data Processing*, for example, the petitioners – organizations who sold data processing services to businesses – challenged a ruling by the Comptroller of Currency that allowed national banks to provide data processing services to other banks and bank customers. 397 U.S. at 151, 90 S.Ct. 827. The Supreme Court held that the Comptroller’s ruling caused petitioners an injury-in-fact because the resulting increase in competition would likely cause petitioners future economic harm. *Id.* at 152, 90 S.Ct. 827. Similarly, in *Clinton* the Supreme Court held that a farmers’ cooperative suffered a concrete injury when the president cancelled a tax benefit enacted to facilitate the purchase of processing plants by such cooperatives. 524 U.S. at 432, 118 S.Ct. 2091. The Court found that “[b]y depriving [the cooperative] of their statutory bargaining chip, the cancellation inflicted a sufficient

likelihood of economic injury to establish standing under our precedents.” *Id.*

In both *Data Processing* and *Clinton*, the government action subjected the challenger to increased competition. The exclusionary right of a patent, however, allows the patent owner to exclude others from competing in its market. But like an action that increases competition, government action that *excludes* an appellant from effectively competing in a market, such as erroneously upholding its competitor’s patent, provides a benefit to the competitor and causes competitive harm to the appellant that presumptively leads to economic injury. *See Canadian Lumber*, 517 F.3d at 1332 (noting that competitor standing “relies on economic logic to conclude that a plaintiff will likely suffer an injury-in-fact when the government acts in a way that increases competition *or aids the plaintiff’s competitors*” (emphasis added)). Thus, I do not believe there is any sound basis for *AVX Corp.*’s patent-specific treatment of the competitor standing doctrine.

The facts of this case further demonstrate why *AVX Corp.*’s patent-specific approach is incorrect. GE and UTC are direct competitors in a fiercely competitive market that requires significant up-front investment years before any profits can be realized. During the engine design process, “airframers explain to GE their needs and requirements for turbofan engines, to enable GE to provide competitive offerings that will satisfy the airframers’ requirements.” Long Suppl. Decl. at 2 ¶ 3. According to GE, one such airframer specifically requested that GE research an engine design that would implicate UTC’s patent. But at least until that patent expires, GE cannot

design and produce such an engine without risking infringement. Thus, UTC's patent effectively precludes GE from meeting its customer's design needs without spending additional resources to design around the patent.¹ I fail to see how this costly competitive burden does not constitute a "concrete and particularized" harm to GE. See *Lujan*, 504 U.S. at 560, 112 S.Ct. 2130. And GE certainly has a "personal stake in the outcome of th[is] controversy," which concerns the validity of a patent owned by its direct competitor covering technology over which the parties compete. *E.P.A.*, 549 U.S. at 517, 127 S.Ct. 1438 (internal quotation marks omitted)

Finally, as the majority correctly notes, we have repeatedly held that the estoppel provisions of 35 U.S.C. § 315(e), standing alone, do not create an injury. Maj. Op. 1354–55. But the effects of that estoppel have especially significant impact where the parties are direct competitors. Unlike the appellant/petitioners in *Consumer Watchdog* or *Phigenix*, who did not manufacture or sell products in the market involving the patented technology, see *Consumer Watchdog*, 753 F.3d at 1260; *Phigenix*, 845 F.3d at 1171, GE is one of three major actors in the turbofan engine market. Although we have not

¹ In *Biotechnology Industry Organization v. District of Columbia*, we found that "[w]hether the Act is enforced or not," pharmaceutical manufacturers challenging a statute that penalized selling prescription drugs at "excessive price[s]" could demonstrate injury-in-fact due to the "actual administrative costs" they would necessarily incur in complying with the statute. 496 F.3d 1362, 1370–71 (Fed. Cir. 2007). Those "actual administrative costs" are analogous to the increased research and design costs that GE has allegedly suffered due to UTC's patent.

decided whether § 315(e) would estop an IPR petitioner who lacked standing to appeal an unfavorable Board decision, *see AVX Corp.*, 923 F.3d at 1363, until we do, UTC's patent is an even greater competitive deterrent for GE. GE faces uncertainty as to whether it is estopped from raising an invalidity defense on any ground "that [it] raised or reasonably could have raised during" its IPR. *See* § 315(e)(2). This uncertainty makes facing potential infringement litigation significantly more impactful on GE's future design choices. Thus, while I agree that 35 U.S.C. § 315(e) estoppel alone does not create an injury-in-fact, its potential effects in this case underscore the problems with our increasingly narrow approach to Article III standing.

Absent *AVX Corp.*, which I believe was incorrectly decided, I would conclude that GE has established Article III standing to appeal the Board's adverse decision. Because I am bound by that precedent, however, I respectfully concur only in the judgment.

Trials@uspto.gov
571-272-7822

Paper 42
Entered: June 26, 2017

UNITED STATES PATENT AND TRADEMARK
OFFICE

BEFORE THE PATENT TRIAL
AND APPEAL BOARD

GENERAL ELECTRIC COMPANY,
Petitioner,

v.

UNITED TECHNOLOGIES CORPORATION,
Patent Owner.

Case IPR2016-00531
Patent 8,511,605 B2

Before HYUN J. JUNG, SCOTT A. DANIELS and
GEORGE R. HOSKINS, *Administrative Patent
Judges.*

DANIELS, *Administrative Patent Judge.*

FINAL WRITTEN DECISION

35 U.S.C. § 318(a) and 37 C.F.R. § 42.73

DANIELS, Administrative Patent Judge.

I. INTRODUCTION

A. Background

General Electric Company (“Petitioner” or “GE”) filed a Petition requesting *inter partes* review of claims 1, 2, and 7–11 of U.S. Patent No. 8,511,605 B2 (Ex. 1001, “the ‘605 patent”). Paper 1 (“Pet.”). GE’s

Petition is supported by declarations from Dr. Reza Abhari (Ex. 1003, “Abhari Declaration,” and Ex. 1036, “Abhari Reply Declaration”). Pet. 4. United Technologies Corp. (“Patent Owner” or “UTC”) filed a Preliminary Response. Paper 6 (“Prelim. Resp.”). On June 30, 2016, the Board instituted a trial, determining that GE had shown a reasonable likelihood of prevailing on at least one of the challenged claims of the ’605 patent. Paper 7 (“Inst. Dec.”) 2.

After institution of trial, UTC filed a Patent Owner Response, along with declarations by Dr. Jack Mattingly (Ex. 2009, “Mattingly Declaration”) and Mr. Paul Duesler (Ex. 2022, “Duesler Declaration”). Paper 15 (“PO Resp.”). GE entered subsequently a Reply (Paper 24, “Pet. Reply”). In a motion authorized by the Board, UTC also moves to strike certain portions of the Abhari Reply Declaration and GE’s Reply. Paper 30. GE provided a rebuttal to UTC’s motion. Paper 34.

Notably, UTC disclaimed claims 1 and 2 of the ’605 patent leaving only claims 7–11 at issue in this proceeding. PO Resp. 5.¹

A hearing for IPR2016-00531 was held on May 4, 2017. The transcript of the hearing has been entered into the record. Paper 41 (“Tr.”).

We have jurisdiction under 35 U.S.C. § 6(c). This final written decision is issued pursuant to 35 U.S.C. § 318(a).

¹ UTC filed a Disclaimer under 37 C.F.R. 1.321 of claims 1–6 and 12–14 in the ’605 patent with the USPTO on October 14, 2016. For completeness of the record, we enter the Disclaimer as Exhibit 3001.

GE has not shown by a preponderance of the evidence that claims 7–11 of the '605 patent are unpatentable, and UTC's motion to strike is denied.

B. Additional Proceedings

In addition to this petition, GE has filed a petition challenging the patentability of claims 1–6 and 12–16 of the '605 patent. *See* IPR2016–00533. GE indicates that they are unaware of any litigation involving the '605 patent. Pet. 1; *see also* Paper 5, 2 (Patent Owner indicating the same).

C. The '605 Patent

The '605 patent issued August 20, 2013 from an application filed May 31, 2012, and claims priority as a continuation-in-part from application No. 12/131,876, filed June 2, 2008, now U.S. Pat. No. 8,128,021. Ex. 1001, cover page. The '605 patent is titled "Gas Turbine Engine With Low Stage Count Low Pressure Turbine." *Id.* at 1:1–2. Figure 1A, reproduced below, illustrates the invention:

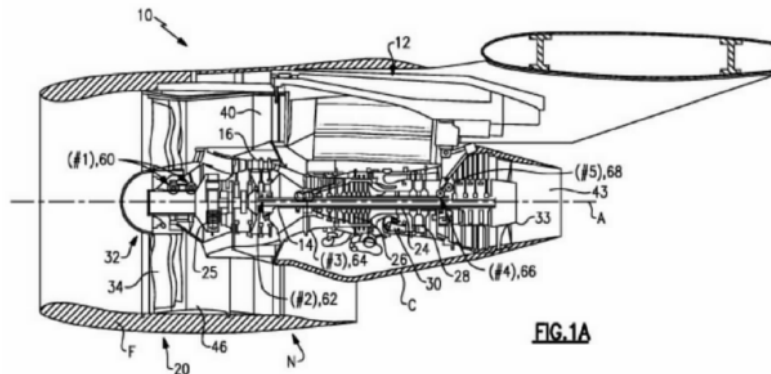

Figure 1A depicts a partial fragmentary schematic view of gas turbofan engine 10 suspended from engine pylon 12. *Id.* at 3:32–34. Turbofan 10 includes fan section 20 within fan nacelle F and a core engine

within core nacelle C. *Id.* at 3:36–39, Fig. 1A. In operation, airflow enters fan nacelle F, which at least partially surrounds core nacelle C. *Id.* at 3:66–67. The fan passes air both into the core engine (core air flow) and around the core engine (bypass air flow). *Id.* The bypass air flow provides a certain amount of the engine thrust as does the core engine, and the low pressure turbine in the core drives the fan. *See id.* at 4:2–12, 4:42–43.

In one described embodiment relevant to the remaining ground in this proceeding, a Variable Area Fan Nozzle, (“VAFN”), varies the fan nozzle exit area in order to adjust the pressure ratio of the fan bypass airflow. *Id.* at 4:31–34. We note the VAFN mechanism is not, apparently, depicted in any of the figures in the ’605 patent. *See* Ex. 1001, Figs. 1–5, *and see* Tr. 5:2. According to the ’605 patent, the VAFN’s ability to selectively adjust the pressure ratio of the bypass air flow, “allows the engine to change to a more favorable fan operating line at low power, avoiding the instability region, and still provide the relatively smaller nozzle area necessary to obtain a high-efficiency fan operating line at cruise.” *Id.* at 4:37–41.

D. Illustrative Claims

The remaining challenged claims are claims 7–11. Claims 1 and 7 illustrate the claimed subject matter and are reproduced below:

1. A gas turbine engine comprising:
 - a gear train defined along an engine centerline axis;
 - a spool along said engine centerline axis which drives said gear train, said spool includes a low stage count low pressure turbine
 - a fan rotatable at a fan speed about the centerline

- axis and driven by the low pressure turbine through the gear train, wherein the fan speed is less than a speed of the low pressure turbine;
- a core surrounded by a core nacelle defined about the engine centerline axis;
- a fan nacelle mounted at least partially around said core nacelle to define a fan bypass airflow path for a fan bypass airflow, wherein a bypass ratio defined by the fan bypass passage airflow divided by airflow through the core is greater than about ten (10).
7. The engine as recited in claim 1, further comprising:
- a fan variable area nozzle *axially movable* relative said fan nacelle to *vary a fan nozzle exit area* and *adjust the fan pressure ratio* of the fan bypass airflow during engine operation.
- Ex. 1001, 7:43–8:7, 8:19–23 (emphasis added). Claims 8–11 depend directly or indirectly from claim 7.

E. The Alleged Ground of Unpatentability

GE contends that the challenged claims are unpatentable on the following specific ground.²

References	Basis	Claims Challenged
Willis ³ and Duesler ⁴	§ 103	7–11

² GE supports its challenge with the Abhari Declarations (Exs. 1003, 1036). *See infra*.

³ William S. Willis, *Quiet Clean Short-Haul Experimental Engine (QCSEE) Final Report* (Aug. 1979) (Ex. 1011).

⁴ US 5,778,659 (July 14, 1998) (Ex. 1006 or Duesler '659).

II. CLAIM CONSTRUCTION

UTC asserts no construction for any claim terms. *See* PO Resp. Although GE proposed constructions for a number of claim terms in its Petition (Pet. 12–22), neither party disputes our initial determination that no claim term requires construction. *See* Inst. Dec. 5, and *see Vivid Techs., Inc. v. Am. Sci. & Eng'g, Inc.*, 200 F.3d 795, 803 (Fed. Cir. 1999) (only those terms which are in controversy need to be construed, and only to the extent necessary to resolve the controversy).

III. ANALYSIS

A. *Claims 7–11 — Alleged obviousness over Willis and Duesler*

GE asserts that claims 7–11 would have been obvious over Willis and Duesler. Pet. 31–43. A patent is invalid for obviousness:

if the differences between the subject matter sought to be patented and the prior art are such that the subject matter as a whole would have been obvious at the time the invention was made to a person having ordinary skill in the art to which said subject matter pertains.

35 U.S.C. § 103. Obviousness is a question of law based on underlying factual findings: (1) the scope and content of the prior art; (2) the differences between the claims and the prior art; (3) the level of ordinary skill in the art; and (4) objective indicia of nonobviousness. *See Graham v. John Deere Co. of Kansas City*, 383 U.S. 1, 17–18 (1966). We must consider all four Graham factors prior to reaching a conclusion regarding obviousness. *See Eurand, Inc. v. Mylan Pharms., Inc. (In re Cyclobenzaprine*

Hydrochloride Extended-Release Capsule Patent Litig.), 676 F.3d 1063, 1076–77 (Fed. Cir. 2012). As the party challenging the patentability of the claims at issue, GE bears the burden of proving obviousness by a preponderance of the evidence. *See* 35 U.S.C. § 316(e).

B. Scope and Content of the Prior Art

1. Willis

Willis, titled “Quiet Clean Short-Haul Experimental Engine,” describes “the design, fabrication, and testing of turbofan propulsion systems for two short-haul transport aircraft and delivery of these systems to NASA for further testing.” Ex. 1011, 019. The developed engines use low-pressure ratio fans at lower fan tip speeds, and also include “[a] variable-area fan-exhaust nozzle [] necessary to keep the fan pressure ratio from dropping too low at cruise.” *Id.* at 026. Figure 8 depicts the Under-the-Wing (UTW) version of Willis’ turbofan engine, Figure 8 is reproduced below:

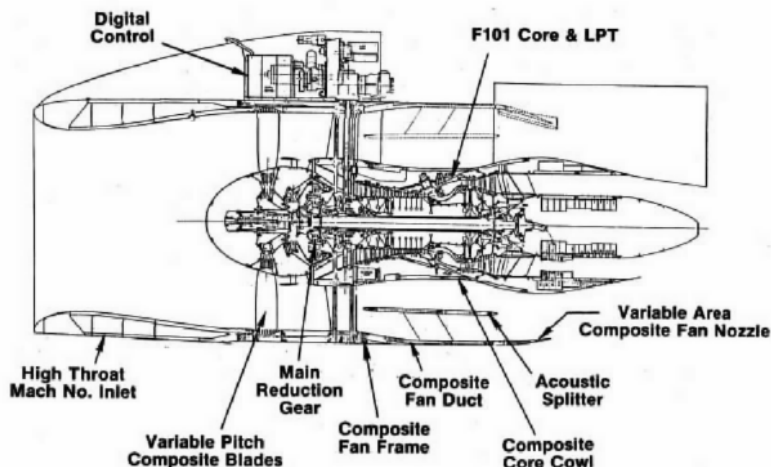

Figure 8. UTW Engine Cross Section.

As depicted in Figure 8 the UTW engine comprises a fan with variable pitch composite blades, a two-stage power turbine driving a star-type, epicyclic main reduction gear, which in turn drives the fan, and, a variable area fan nozzle. *Id.* at 032–033. Willis depicts a radially hinged flap acting as a VAFN, labeled “Variable Area Composite Fan Nozzle,” in Figure 8, above. Willis explains that in Figure 8 “[t]he fan nozzle is shown in the cruise position. It opens part way for takeoff and approach and further for reverse, where it functions as an inlet.” *Id.* at 032.

2. Duesler '659

Duesler '659 describes a variable area fan exhaust nozzle for an aircraft gas turbine engine. Ex. 1006, 1:12–20. An annotated version of Figure 2 depicts the downstream portion of outer nacelle 20 with translating sleeve 38, which we highlight in yellow, Figure 2 annotated is reproduced below:

27a

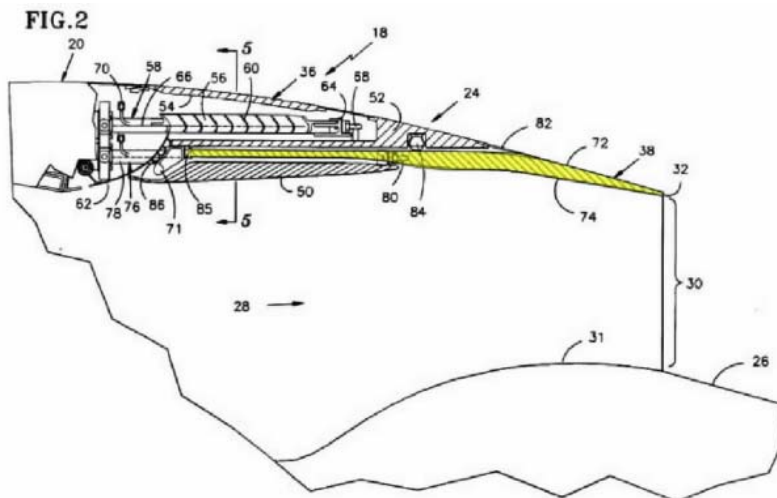

Figure 2, as annotated above, depicts downstream portion 24 of outer nacelle 20 including fixed geometry fan exhaust nozzle translating sleeve 38 disposed in a stowed position. *Id.* at 4:22–26, 49–51. The sleeve is translatable between the stowed position and a deployed position, illustrated below, in Figure 3. *Id.* at 4:52–55.

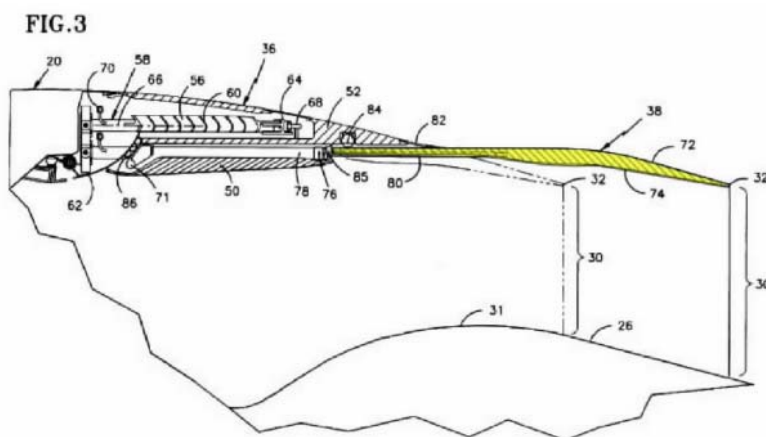

Figure 3 depicts fan exhaust nozzle translating sleeve 38, highlighted in yellow, disposed in a

deployed position. *Id.* As shown by comparing reference numbers 30 and 30' in Figure 3, aftward movement of the sleeve causes an increase in the throat area while forward movement causes a decrease in the throat area. *Id.* at 4:58–61. This movement between the stowed and deployed positions is the exclusive means for varying the throat area and the quantity of forward thrust from gases discharged from the duct. *Id.* at 4:55–58.

C. Differences Between the Prior Art and the Claimed Invention

Claim 1

Claim 7 depends directly from claim 1, and by its dependency, includes all the limitations of claim 1. *See* Ex. 1001, 7:43–8:7, 8:19–23. GE argues that Willis anticipates and discloses each limitation in claim 1. Pet. 24–31. UTC has now disclaimed claim 1. PO Resp. 5. We were persuaded in our Decision to Institute that GE “demonstrated a reasonable likelihood of prevailing at trial on its challenge of claims 1 and 2 as anticipated by Willis.” Inst. Dec. 7. UTC presents no arguments in its Response contradicting GE’s assertions of anticipation or refuting the Board’s anticipation analysis in our Decision to Institute with respect to claim 1.

We adopt GE’s contentions as our findings with regard to anticipation of the challenged independent claim 1 because, upon review of the full record in this proceeding, the cited portions of Willis reasonably support GE’s assertions that the elements of claim 1 are known and explicitly shown by Willis. *See* Pet. 24–31 (citing Exs. 1003 ¶ 64–72; 1011, .024, .026, .032, .034, .088, .092, .135).

Claim 7

To meet the “fan variable area nozzle axially moveable” limitation recited in claim 7, GE relies on Duesler’s translating sleeve 38 in combination with Willis. Pet. 31–37. GE contends that “Duesler discloses a variable area fan nozzle that varies the nozzle exit area with an axially movable sleeve.” Pet. 32–33 (citing Ex. 1006, 2:48–58; Ex. 1003 at ¶ 75). GE asserts that a person of ordinary skill in the art would have known about different structures for varying the fan nozzle exit area and that “a variable area fan nozzle could include a plurality of flaps actuated in the radial direction, *or* a sleeve that is actuated in the axial direction.” *Id.* at 33 (emphasis added) (citing Ex. 1006, Ex. 1008).

Relying on its declarant, Dr. Abhari, a Professor of Aerothermodynamics and the Director of the Laboratory for Energy Conversion in Zurich, Switzerland, GE argues that substituting translating sleeve 38 of Duesler, for the flaps in Willis is just a design choice, and, “simply the application of a known structure to achieve a predictable result (adjusting the nozzle exit area).” *Id.* at 33 (citing Ex. 1003 ¶ 77). Dr. Abhari opines that one of ordinary skill in the art understands that the hinging flap structure in Willis is interchangeable with sleeve 38 from Duesler to serve the same purpose, i.e. varying the fan nozzle exit area. Ex. 1003 ¶ 77 (“The radially moveable flaps and axially moveable sleeve are both known structures used for the same purpose—varying the fan nozzle exit area.”). Dr. Abhari states for example that hinged flaps “can be advantageous for military applications (e.g., fighter jets) that require optimal performance and maneuverability.” *Id.* ¶ 78 (citing Ex. 1014, .100–.101). On the other hand, by using a

translating sleeve “airflow leakage is minimized because the nozzle is comprised of only a few components and therefore has a relatively continuous inner surface.” *Id.* (citing Ex. 1006, 3:21–25). Size, weight, and cost are other factors noted by Dr. Abhari for choosing one structure over the other. *Id.*

UTC disagrees with Dr. Abhari’s assertion that substituting Duesler’s translating sleeve 38 for Willis’s radially moveable flaps is simply a matter of “design choice.” PO Resp. 28. UTC points out that the primary objective of the Willis engine was specifically to have a high reverse-thrust for very short runways. *See id.* at 29 (“creating an engine capable of effective reverse thrust and very low noise was Willis’s intended purpose and principle of operation”). UTC argues that the “proposed substitution would change the principles under which the Willis engine was designed to operate and render the engine unsuitable for its intended purpose.” *Id.* at 30 (citing *Plas-Pak Indus., Inc. v. Sulzer Mixpac AG*, 600 F. App’x 755, 758 (Fed. Cir. 2015)).

Specifically, UTC argues that “Duesler’s translating-sleeve nozzle can only serve effectively as an exhaust *and not an inlet*, so it could never meet the reverse-thrust requirements that are central to Willis’s mission.” *Id.* at 2–3. In support of this position UTC provides testimony from Dr. Jack D. Mattingly, Professor Emeritus of Mechanical Engineering at Seattle University College of Science and Engineering. Ex. 2009 ¶ 3. Also, UTC presents testimony from Paul W. Duesler, the first named inventor of the Duesler ’659 patent. *See* Ex. 2022; *see also* Ex. 1006, “Cover Page.” Based on Dr. Mattingly’s testimony, UTC alleges that one of ordinary skill in the art would not combine Duesler with Willis

because Duesler “would render Willis’s engine inoperable for its intended purpose.” PO Resp. 29. Specifically, UTC contends that using Duesler’s sleeve would make Willis’s reverse-thrust “performance worse” and the engine “too loud” for Willis’s stated noise design requirements. *Id.* at 35–36.

We agree with GE that Duesler’s translating sleeve 38, and the pivoting flaps used in the Willis engine, accomplish at least one common task, that is—varying the fan outlet area. *Compare* Ex. 1006, 2:66–3:1 *with* Ex. 1011, .032 (Willis’s “[fan nozzle] opens part way for takeoff and approach and further for reverse, where it functions as an inlet.”). Both Dr. Abhari and Dr. Mattingly provide testimony supporting the determination that Duesler and Willis both disclose a variable area fan nozzle (VAFN). *Compare* Ex. 1003 ¶¶ 75–77 *with* Ex. 2009 ¶¶ 51, 65. The question addressed below is whether one of ordinary skill in the art would have, as a matter of design choice and given that both structures vary the fan outlet (exhaust) area of a turbofan engine, substituted Duesler’s axially translating sleeve nozzle configuration for the radially hinged VAFN structure in Willis?

D. The Level of Ordinary Skill in the Art

GE’s declarant, Dr. Abhari, testifies that a person of ordinary skill in the art “would include someone who has a M.S. degree in in Mechanical Engineering or Aerospace Engineering as well as at least 3–5 years of experience in the field of gas turbine engine design and analysis.” Ex. 1003 ¶ 4. Disagreeing with Dr. Abhari’s opinion as to the years of experience one of

ordinary skill would have in this field, Dr. Mattingly states that:

a person of ordinary skill in this art would have . . . at least ten years of work experience or equivalent study in the design of gas turbine engines for aircraft. Persons of ordinary skill in the art typically have worked as component designers, gained familiarity with engine components, and then been promoted to system-level design responsibilities.

Ex. 2009 ¶ 40.

The difference in opinion between declarants fails mainly to settle on a time frame, i.e. years of experience, in aircraft gas turbine engine design, that a person of ordinary skill in the art would generally have. These positions, however, are not as far afield as they might seem. We recognize from Dr. Abhari's and Dr. Mattingly's testimony that gas turbine aircraft engines and their operating conditions are functionally and structurally complex. *See* Ex. 1003 ¶¶ 21, 53, 55, 60; Ex. 2009 ¶ 38. From the testimony of both declarants we understand that a person of skill in the art of aircraft turbine design is not a newly minted mechanical or aeronautical engineer fresh from undergraduate, or even graduate studies, without a number of years of work experience in the field of aircraft engine design. *See* Ex. 1003 ¶ 4, *and see* Ex. 2009 ¶ 40. Our review of the prior art in conjunction with the declarants' testimony informs us of the complexity of the structural and functional aspects of aircraft engine design and indicates that the level of ordinary skill in the art of aircraft turbofan engine design is fairly high, requiring significant time working in the field. We reconcile the

declarants' inconsistent statements as to years of work experience by determining that a person of ordinary skill in the art of gas turbine engines for aircraft would have a professional background that includes at least an M.S. degree in mechanical or aeronautical engineering and, along with whatever additional engineering background knowledge and skill set they possess, at least 5–10 years of work and study experience in design and analysis of aircraft gas turbine engines. We point out that regardless of the difference in years of experience asserted by the declarants, our ultimate findings and conclusions would be the same under either definition.

E. Secondary Considerations of Non-Obviousness

Evidence of secondary considerations of non-obviousness, when present, must always be considered en route to a determination of obviousness. *See Cyclobenzaprine*, 676 F.3d at 1075–76. However, the absence of secondary considerations is a neutral factor. *See Custom Acc., Inc., v. Jeffrey-Allan Indus., Inc.*, 807 F.2d 955, 960 (Fed. Cir. 1986). Neither party introduced evidence on secondary considerations of nonobviousness. Consequently, we will focus our attention on the first three *Graham* factors.

F. Whether the Prior Art Could Have Been Combined and/or Substituted to Achieve the Claimed Invention

The Supreme Court instructs us to take an expansive and flexible approach in determining whether a patented invention was obvious at the time it was made. *See KSR Int'l Co. v. Teleflex Inc.*, 550 U.S. 398, 415 (2007). Where “a patent claims a

structure already known in the prior art that is altered by the mere substitution of one element for another known in the field, the combination must do more than yield predictable results.” *Id.* at 416. It is well settled, however, that prior art combinations cannot change the “basic principles under which the [prior art] was designed to operate.” *In re Ratti*, 270 F.2d 810, 813 (1959). Also, a combination that renders prior art “inoperable for its intended purpose,’ may fail to support a conclusion of obviousness.” *Plas-Pak Indus., Inc. v. Sulzer Mixpac AG*, 600 F. App’x 755, 757–58 (Fed. Cir. 2015) (citing *In re Gordon*, 733 F.2d 900, 902 (Fed. Cir. 1984)).

UTC argues that the proposed combination changes the principle of operation of Willis’s engine, and would make Willis’s engine inoperable for its intended purpose by having decreased reverse-thrust capability that could not stop an aircraft on a short runway, and that it would also make the engine noisier. PO Resp. 30. Alleging that the Willis engine would, thus, become unsuitable for its intended purpose of powering “a fleet of new aircraft that would operate from smaller airports close to city centers,” (Ex. 1011, .024) UTC asserts that a person of ordinary skill in the art of gas turbine aircraft engine design would not simply substitute Duesler’s translating sleeve for Willis’s pivoting flap design. *Id.*

The stated objective of the Willis engine development program was “to develop the technology needed to meet the stringent noise, exhaust emissions, performance, weight, and transient thrust-response requirements of future short-haul aircraft” so aircraft could land in smaller airports closer to population centers. Ex. 1011, .019, .024. These objectives were based on

major problems facing the air transport industry in the early 1970's [including] noise and airport congestion. Noise had forced the closing of certain runways, the imposition of curfews at some airports, and the use of special flight restrictions The congestion problem was manifested by traffic and parking problems, baggage-handling delays, and (especially in bad weather) long delays in departures and arrivals due to congested air space.

Id. at .024. To develop a feasible engine for “short-haul” aircraft that could land on a very short runway in smaller airports, Willis discloses an engine having a variable pitch fan, that is—a fan that is arranged in a pitch angle producing forward thrust, and then moved, i.e. closed, to a pitch angle producing reverse-thrust through the engine. *See id.* at .043 (“During closure, the normal forward flow drops smoothly to zero, then reverse flow is gradually established.”). To adequately stop an aircraft, Willis required a combination airflow and pressure ratio across the fan to meet the reverse-thrust objective of 35% of the forward-thrust. *Id.* at .049.

Additionally, as depicted in Willis’s Figure 3 another goal was to keep the noise level below a certain level because smaller airports accommodating such short-haul aircraft were closer to busier population centers. *Id.* at .024–.025.

Willis Figure 3 is reproduced below:

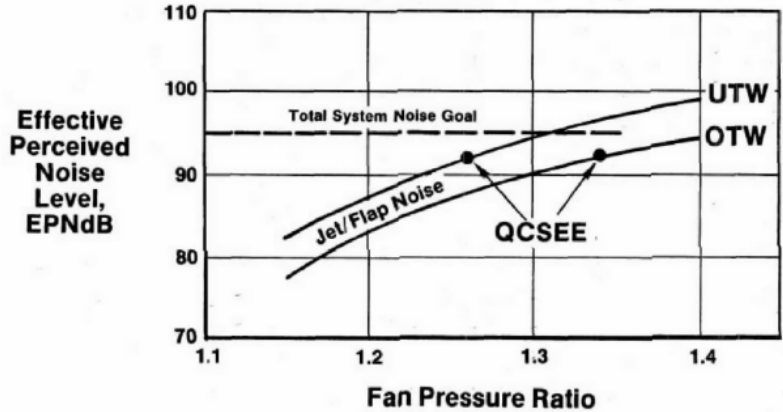

Figure 3. Effect of Jet Flap Noise on Fan Pressure Ratio Selection.

Figure 3 from Willis illustrates graphically fan pressure ratio as a function of noise level, and a desired total system noise goal. *Id.* at .025.

Based on these goals, the structural and functional design requirements for Willis's short-haul engine are quite specific as shown listed, below, in Willis's Table III.

Table III. UTW Design Parameters.

Total Airflow, kg/s (lb/sec)	_____	405.5 (894)
Fan Tip Diameter, cm (in.)	_____	180.3 (71)
Fan Tip Speed, m/s (ft/sec)	_____	289.6 (950)
Bypass Ratio	_____	11.8
Fan Pressure Ratio	_____	1.27
Overall Pressure Ratio	_____	13.7
Jet Velocity (Core), m/s (ft/sec)	_____	244.7 (803)
Jet Velocity (Bypass), m/s	_____	204.2 (670)
Gear Ratio	_____	2.5

Ex. 1011, .034.

A cross-section of Willis's Under-the-wing ("UTW") engine as designed based on the stated objectives and requirements is shown, below, in Figure 8 reproduced from Willis.

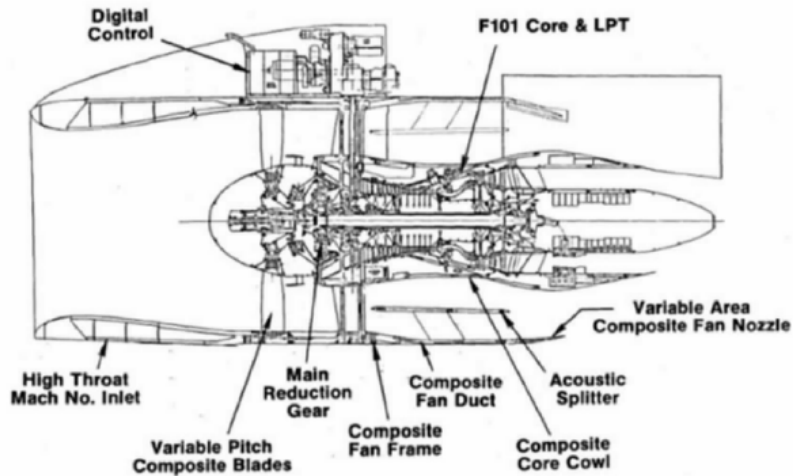

Ex. 1011, .033. Willis discloses in Figure 8 an inlet as depicted and labeled on the left side of the figure, and a nozzle defined between the pivoting flaps and the core on the right side of the figure. In the forward-thrust state, the airflow through the fan enters the inlet and emanates from the nozzle. *Id.* at .032. In the reverse-thrust state, the airflow is reversed to help brake the aircraft upon landing, with the air entering the engine through the nozzle and exiting from the engine inlet. *Id.* Willis's nozzle flaps pivot about a connection between the base of the flap and the outer nacelle to vary the fan nozzle area. *Id.* at .134, Fig. 74. Figure 8 illustrates the flaps in a cruise position, and in the image of Figure 74 the flaps are shown, open, in a reverse-thrust position. *Id.* at .032-.033, .128, .134. Figure 74 is reproduced below:

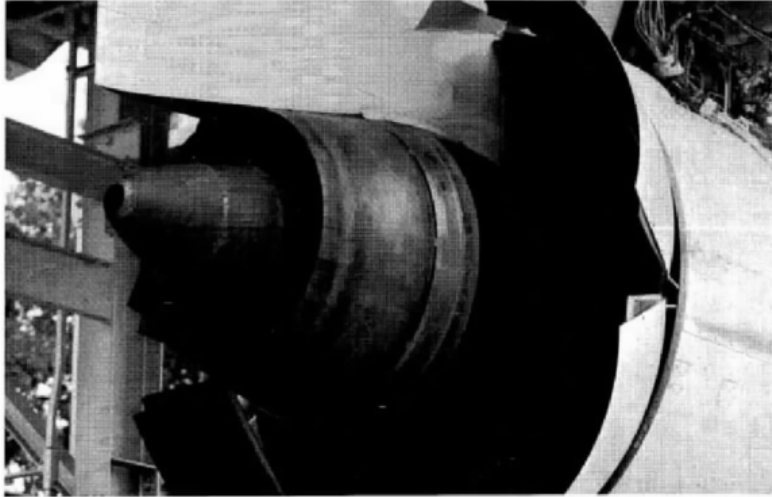

Figure 74. Fan Nozzle.

In the reverse-thrust position shown in Figure 74 Willis's flaps are open, showing how the nozzle structure now acts as an inlet when the variable pitch fan blades are altered to produce a reverse airflow through the engine and hence, reverse-thrust. Ex. 1011, 32, 34–35, 134; Ex. 2009 ¶ 60.

UTC's declarant, Dr. Mattingly, testifies that pivoting flaps "have the ability to open wider than the fan nacelle itself, enabling Willis to draw in the necessary airflow to produce sufficient reverse thrust." Ex. 2009 ¶ 60. Dr. Mattingly explains that the flap structure is important "because most of the airflow does not enter the nozzle in a straight or linear direction, but rather it approaches at a steep angle." *Id.* ¶ 61. Dr. Mattingly provides an annotated Figure from his own textbook, illustrating this steep angle, defined by air having a Mach number close to 0. *Id.* Dr. Mattingly explains that based on such airflow and flap structure "a person of ordinary skill in the art would recognize that the thrust reverser of Willis's

UTW engine is an effective design for generating the large amount of reverse thrust (e.g., 35% of max forward thrust) needed to stop quickly on a short-haul runway (2000 feet).” *Id.* ¶ 62. Dr. Mattingly explains further that Duesler’s translating sleeve nozzle does not function as an inlet and “the engine would not be able to draw air in over the sharp, axial-direction trailing edge 32 of the sleeve 38.” *Id.* ¶ 72.

Hypothesizing that Duesler’s sleeve could act as an inlet, Dr. Mattingly offers a summary of inlet area geometry and air flow comparison calculations between Willis’s and Duesler’s nozzles, asserting that Duesler’s nozzle has a 28–37% higher inlet drag, i.e. loss of reverse-thrust, compared to Willis’s nozzle. *Id.* ¶¶ 90–94. Based on his calculations of reverse-thrust loss in Duesler, Dr. Mattingly states

A person of ordinary skill in the art would view this as especially critical to Willis’s short-haul goal for an “effective thrust reverser (GE–1011.026) that could produce up to 35% of its forward thrust in reverse (GE–1011.301) and . . . would not view the Willis-Duesler combination as an effective thrust reverser.

Id. ¶ 95.

Dr. Mattingly testifies further that Duesler’s translating sleeve would exceed the noise requirements for Willis’s engine of “100 dB at a 500-foot sideline for maximum reverse thrust” *Id.* ¶ 95 (citing Ex. 1011, 19). Dr. Mattingly states that

[a] person of ordinary skill in the art would recognize that attempting to draw in a large amount of air over Duesler’s sharp, trailing edge 32 at maximum [reverse] thrust on the UTW engine would generate noise well above Willis’s

intensity limit. This would have been unacceptable in the congested areas where Willis's short-haul airports are located.

Id. ¶ 96.

In response, GE points out that its obviousness analysis rests simply on the substitution of Duesler's translating sleeve for Willis's flaps.⁵ See Pet. Reply 4. GE relies mainly on the testimony of Dr. Abhari that both types of variable area nozzles were known in the art at the time of filing of the '605 patent. Pet. 33 (citing Exs. 1006, 1008); Pet. Reply 6 (citing Ex. 1003 ¶ 77; Ex. 2019, 112 at 399:7–14, 128 at 415:5–17). GE points out that Dr. Mattingly was unable to rebut Dr. Abhari's testimony that axially moveable variable area fan nozzles were known in the art. Pet. Reply 7–8.

GE argues also that Dr. Abhari provided sufficient evidence of motivation to combine, i.e. a reason to substitute an axially moveable sleeve for the hinged flaps in Willis because with a translating sleeve "airflow leakage is minimized because the nozzle is comprised of only a few components and therefore has a relatively continuous inner surface." Pet. Reply 9 (citing Ex. 1003 ¶ 78). GE contends further that the "intended purpose" proposed by UTC for Willis's engine is too narrow because "[r]everse thrust mode

⁵ GE takes issue with UTC's analysis of the combination of Duesler's thrust reversing mechanism in addition to the translating sleeve. Pet. 4–5; see also PO Resp. 22–25. GE asserts Duesler's thrust reversing mechanism and blocking doors is not part of the combination of references asserted by GE. Pet. Reply 4–5. Our analysis in this Final Written Decision rests only on the asserted substitution of Duesler's translating sleeve 38 for Willis's hinged flaps.

accounts for several seconds of engine operation, while the engine also must take-off, climb, cruise, and descend.” *Id.* at 13. GE argues also that Dr. Mattingly’s conclusion that Duesler would be louder than Willis’s engine is unsubstantiated by sufficient facts or data and that we should give this testimony no weight. *Id.* at 13–14 (citing 37 C.F.R. § 42.65).

It is GE’s ultimate burden of persuasion to show by a preponderance of the evidence that a person of ordinary skill in the art would have been motivated to use an axially translating sleeve in place of Willis’s radially hinged flaps. *See Dynamic Drinkware, LLC v. National Graphics, Inc.*, 800 F.3d 1375, 1378 (Fed. Cir. 2015) (“In an *inter partes* review, the burden of persuasion is on the petitioner to prove ‘unpatentability by a preponderance of the evidence,’ 35 U.S.C. § 316(e), and that burden never shifts to the patentee[.]”). On the other hand, the burden of production, i.e. the burden of going forward with evidence, shifts between parties. *Id.* at 1379.

As noted above, our review of the asserted references, along with the testimony of both Dr. Mattingly and Dr. Abhari, supports the conclusion that Duesler and Willis disclose different structures that perform the function of varying the fan nozzle exhaust area, and thus, are both understood by those of ordinary skill in the art as variable area fan nozzles. *See Ex. 1006, 4:52–58 and see Ex. 1011, .032.* Thus, GE’s argument that Dr. Mattingly could not “rebut” Dr. Abhari’s testimony that such structures were known in the art is of no consequence. Dr. Mattingly, in fact, appears to agree, although he is somewhat reticent to discuss specifics of Duesler’s nozzle, and the fact that both Willis and Duesler disclose VAFN’s that vary the nozzle exhaust area.

See Ex. 1033, 90:9–12 (“When I compared the radial variable nozzle of Willis to the axial variable fan nozzle of Duesler, it’s my opinion that the Duesler nozzle is heavier.”).

Dr. Abhari asserts in his declaration that substituting the axial translating sleeve 38 from Duesler into Willis’s engine “is simply the application of a known structure (an axially movable fan nozzle) to achieve a desired and predictable result (changing the nozzle exit area).” Ex. 1003 ¶ 77. Dr. Abhari explained that the choice of whether to use an axial sleeve or a radially hinged flap as a nozzle can depend on certain “factors.” *Id.* ¶ 78. For example, Dr. Abhari described that where “thrust vectoring” is desired in military aircraft for maneuverability, a radially hinged flap nozzle is preferable. *Id.* If control of airflow leakage from the nozzle is desired to be minimized for better propulsive efficiency, then a sliding sleeve design is preferable as it “has a relatively continuous inner surface.” *Id.* (citing Ex. 1006, 3:21–25). Dr. Abhari also noted that “size, weight and cost” can affect the design choice between variable area nozzle structures. *Id.*

GE contends that Dr. Abhari’s testimony supplies adequate reasons and motivation to substitute Duesler’s sleeve into Willis’s engine particularly where he alleges that by using a translating sleeve design “airflow leakage is minimized . . . which Duesler describes as beneficial to engine performance.” Pet. Reply 9 (citing Ex. 1006, 1:53–55). The problem, however, is that Dr. Abhari’s asserted “factors” do not substantively explain why or how Duesler’s translating sleeve would affect the stated purposes and explicit design parameters of Willis, which are aimed at “develop[ing] the technology

needed to meet the stringent noise, exhaust emissions, performance, weight, and transient thrust-response requirements of future short-haul aircraft,” as discussed above in our factual findings. We are not apprised by GE or Dr. Abhari of any aspect of Willis that relates specifically to “military aircraft maneuverability.” Our review reveals Willis’s express objective is developing a turbofan engine intended for “short-haul-transport aircraft” for very short take-off and landing, which requires “a reverse-pitch fan that can provide reverse thrust without heavy, variable-geometry, nacelle components.” Ex. 1011, .024, .026. As shown in annotated Table 1, reproduced below, Willis explicitly sets forth program goals and parameters needed to be met by the engine design “to meet the stringent noise, exhaust emissions, performance, weight, and transient thrust-response requirements of future short-haul aircraft.” *Id.* at .019.

Table I. QCSEE Program Goals.

Parameter	UTW	OTW
Noise at 152.4 m (500 ft) Sideline		
Takeoff and Approach, EPNdB	95	95
Maximum Reverse Thrust, PNdB	100	100
Exhaust Emissions	1979 EPA Standards for Carbon Monoxide, Unburned Hydrocarbons, and Oxides of Nitrogen	
Performance		
Uninstalled Thrust, kN (lbf)	81.4 (18,300)	93.4 (21,000)
Installed Thrust, kN (lbf)	77.4 (17,400)	90.3 (20,300)
Uninstalled sfc, g/sec/N (lbm/hr/lbf)	0.0096 (0.34)	0.0102 (0.36)
Max Reverse Thrust, % of Max Forward	35	35
Thrust to Weight Ratio, N/kg (lbf/lbm)		
Uninstalled	60.8 (6.2)	72.6 (7.4)
Installed	42.2 (4.3)	46.1 (4.7)
Thrust Transient, seconds		
Approach to Takeoff	1	1
Approach to Max Reverse	1.5	1.5

Exemplary goals for Willis's engine are shown highlighted in yellow in Table 1, above, including maximum desired noise at max reverse thrust of 100 PNdB, max reverse thrust of 35% of forward thrust, and thrust transient characteristics from aircraft landing approach to max reverse of 1.5 seconds.

Willis is replete with structural design characteristics based on the noted goals, such as turbofan variable pitch blades to ensure quick thrust transient from approach to max reverse for braking, with all the engine structural design focused on ensuring that aircraft are capable of take-off and landing on very short runways and meeting specific noise parameters. *See id.* at .026; *see also id.* at .032 (“[r]ecognizing the critical nature of the blade pitch-control system, many concepts were studied, and two variable-pitch systems were built and tested”). Dr. Abhari's general reference to certain “factors” for choosing between different variable nozzle structures fails to address in a meaningful manner any of the express requirements, goals and characteristics discussed in Willis. For example, in order to land on a short runway, the Willis engine must be capable of generating a max reverse thrust of 35% of forward thrust. *Id.* at .019, Table 1. Nowhere does Dr. Abhari provide any estimate, or provide a technical explanation or analysis that sufficiently explains how Willis's engine, equipped with Duesler's axially translating nozzle, could be understood by one of ordinary skill in the art to accommodate such a reverse thrust parameter.

We do not discount entirely Dr. Abhari's testimony, because we find it persuasive as to the general desirability of using variable area fan nozzles to improve fan stability and engine efficiency at

cruise. *See* Ex. 1003 ¶ 75. Based on a review of the prior art and both parties' declarant testimony, we find that a person of ordinary skill in the art of gas turbofan aircraft engines would have recognized "that there are a variety of variable area fan nozzle structural configurations possible for effectuating a change in the nozzle exit area." *Id.* ¶ 77, Ex. 1006; Ex. 1008. But, the Willis engine is directed expressly to "short-haul" capabilities including take-offs and landings on very short runways, not to engine efficiency at cruise. *See* Ex. 1011, .024. To be clear, Dr. Abhari's testimony does not go far enough in explaining persuasively why a person of ordinary skill in the art would have substituted Duesler's nozzle into Willis's engine given the express purposes of Willis.

Dr. Abhari testifies that gas turbofan engines are complicated systems that depend on "thousands, often tens of thousands of parts." Ex. 2018, 79:1-2. Dr. Abhari testifies further that aircraft engine design required a "holistic" approach to understand how the engine would perform in all situations and operating conditions including emergency conditions:

Q. I think you mentioned before that the systems, the holistic systems approach is critical, correct?

A. Absolutely. You wouldn't function without it.

Q. And you would have to look at that in order to have a reasonable expectation of success, correct?

MR FERGUSON: Objection. Outside the scope of the declaration.

A. Again this is not within the patent, but holistic design and aircraft engine, the safety of an aircraft engine number one, necessitates understanding

how the engine works, not only during one operating condition but during all operating conditions, including emergency conditions that we have to anticipate. So the engine does not have just one point that you can take every design point, you have to look at it in a holistic approach of how it would work on a wing, start up, go up to take off, climb, cruise, descend, land turn it off. It has to work as a whole system.

Id. at 82:14–83:10. Dr. Abhari also testifies that the engine development process, including verification and certification, can take years:

Q. And without all this verification testing that you mention; the components, the engine, bird damage, fan blade off, icing, the testing on the wing, you don't have a reasonable expectation of getting verification by the regulators, correct?

A. Well, the three major engine manufacturers; Pratt, GE and Rolls Royce have sufficient management to manage the risk that often you don't go all the way down to the final certifications without a significant chance of success. This is why prior to going into certification, which would take many years, three, four, five years, you spend as many as a decade de-risking components, systems and sub systems before you take the management risk of actually going to the most expensive part of the engine development cycle, which is the certification requirements.

Id. at 74:18–75:10. This testimony is at odds with GE's general contention that choosing an axially movable fan nozzle as in Duesler instead of a radially movable nozzle is a simple matter of substitution. Pet. 33–34, Pet. Reply 5–6. In fact Dr. Abhari's

testimony is more consistent with similar testimony from Dr. Mattingly, who states that:

[a] person of ordinary skill in the art would recognize that the components of gas turbofan engines are complex and interrelated, and that modifying one component may have undesirable impacts on the fluid dynamics and mechanics of other engine components, systems, or the engine as a whole. The '605 patent, for example, discloses a system of components, not just an individual engine component. The disclosed system includes a gas turbine engine comprising a fan, a gear, compressors, a combustor, turbines, a core nozzle, a variable area fan nozzle, and the core and fan nacelles. In my opinion, a person of ordinary skill in the art would also recognize the potential challenges in adapting components from one gas turbofan engine to another.

Ex. 2009 ¶ 38.

We are not persuaded, given the apparent necessity for years of testing, regulatory oversight, and necessity to evaluate the overall system and individual components based on stringent structural and functional requirements of an aircraft turbofan engine, that one of ordinary skill in the art would have been motivated to exchange Willis's hinged flap variable area nozzle for an axially translating sleeve such as Duesler simply because it might be "beneficial to engine performance." Pet. Reply 9 (citing Ex. 1006, 1:53-55). Apart from the alleged potential to overcome "airflow leakage" and "maneuverability" which are not mentioned as any of the express

parameters, goals or system requirements in Willis, neither GE nor Dr. Abhari explain sufficiently how an axially translating sleeve would accommodate the very specific requirements and goals mandated for Willis's engine such as those shown above in Table 1.

We are persuaded based on our review of Willis and the record of this proceeding that Willis's variable pitch fan and pivoting flap variable area nozzle are together implemented in turbofan aircraft engine in a manner which provides for solving the unique problems of short-haul aircraft systems as described in Willis. Based on our understanding of the principles of operation of Willis's engine including the necessity for substantial increased reverse-thrust and reduced noise, we find that Duesler's translating sleeve would alter fundamentally the design of Willis's engine for short-haul aircraft.

Under our rules, expert testimony that does not disclose the underlying facts or data on which an opinion is based is entitled to little or no weight. *See* 37 C.F.R. § 42.65(a); *Office Patent Trial Practice Guide*, 77 Fed. Reg. at 48,763; *Rohm & Haas Co. v. Brotech Corp.*, 127 F.3d 1089, 1092 (Fed. Cir. 1997) (nothing in the Federal Rules of Evidence or Federal Circuit jurisprudence requires the fact finder to credit unsupported assertions of an expert witness). We are not inclined to credit such unsubstantiated testimony.

In an obviousness analysis, a reason must be given as to why a person of ordinary skill would have been motivated to modify a reference to achieve the patented invention. *See Innogenetics, N.V. v. Abbott Labs.*, 512 F.3d 1363, 1374 (Fed. Cir. 2008). Furthermore, an obviousness determination requires not only a reason to modify a prior art reference, but also that a skilled artisan in doing so would have

perceived a reasonable expectation of success in making the invention. *See Medichem, S.A., v. Rolabo, S.L.*, 437 F.3d 1157, 1165 (Fed. Cir. 2006). Although GE contends that Dr. Abhari provided sufficient reason to combine, we disagree. *See* Pet. Reply 8–9. On the record before us, we are not persuaded that GE or Dr. Abhari have presented sufficient evidence that one of ordinary skill in the art of aircraft engine design would simply swap Willis’s pivoting flap variable area nozzle for Duesler’s translating sleeve and that Willis’s engine would continue as a technically feasible solution to the specific and express “short-haul” aircraft concept that Willis’s engine was designed to accomplish.

G. Ultimate Conclusion of Obviousness as to claims 7–11

After considering all of the underlying factual considerations, the ultimate conclusion of obviousness is a question of law. *See Pfizer, Inc. v. Apotex, Inc.*, 480 F.3d 1348, 1359 (Fed. Cir. 2007). “[T]he great challenge of the obviousness judgment is proceeding without any hint of hindsight.” *Star Scientific, Inc., v. R.J. Reynolds Tobacco Co.*, 655 F.3d 1364, 1375 (Fed. Cir. 2011). After considering GE’s obviousness presentation under the *Graham* factors and GE’s lack of evidence on how or why a person of ordinary skill in the art would have modified Willis’s engine to achieve the patented invention, we conclude that GE has failed to establish by a preponderance of the evidence that claim 7 is obvious.

In view of our determination that GE has failed to establish that dependent claim 7, as it also incorporates independent claim 1, would have been obvious, it necessarily follows that GE has failed to

establish that dependent claims 8–11 which depend from claim 7 are unpatentable as obvious. *See In re Fritch*, 972 F.2d 1260, 1266 (Fed. Cir. 1992) (dependent claims are nonobvious if the independent claims from which they depend are nonobvious).

H. Patent Owner’s Motion to Strike

In an Order entered February 10, 2017, we authorized UTC to file a paper in the form of a list providing the location and a concise description of any portion of GE’s Reply and Dr. Abhari’s supplemental declaration that UTC wished to draw to the Board’s attention. *See* Paper 27. In its Motion to Strike (Paper 30), UTC noted pages 15–22 in GE’s Reply Brief, and ¶¶ 6–8 of Dr. Abhari’s supplemental declaration. Paper 30. We address each of these issues below.

GE’s Reply Brief at the noted pages contends that the combination of Willis and Duesler would produce an effective amount of reverse thrust and that the effects of flow separation are overstated by UTC’s declarants, Dr. Mattingly and Paul Duesler. Pet. Reply 15. GE also relies on a patent (Exhibit 1031), to Rolls Royce, U.S. Patent No. 3,820,719 (“the ’719 patent”) alleging that the ’719 patent discloses an axially translating variable area nozzle that promoted reduced flow separation. *Id.* at 19–20.

The arguments in GE’s Reply with respect to the issue of flow separation are not persuasive because they do not provide substantive evidence relating to flow separation or reverse thrust analysis in Duesler’s translating sleeve, assuming it were to act as an inlet for reverse-thrust (as opposed to an outlet). *Id.* at 15. GE contends mainly that the Willis engine also has “flow separation.” *Id.* at 16–17.

We note initially that we did not rely on Mr. Duesler's testimony in our Decision. *See id.* at 17–18. Dr. Mattingly, however, explained in reasonable technical detail, why Willis's flaps, as compared to Duesler's sleeve, permit higher airflow in reverse thrust at a Mach number closer to 0, apparently despite some flow separation in a reverse thrust mode. *See* Ex. 2009 ¶¶ 59–61 (“In reverse thrust mode, the air entering Willis's UTW engine would follow the wide streamline corresponding to nearly $M_0 = 0$, annotated above. Willis's flaps open widely in reverse thrust mode to accommodate this streamline.”). GE's position that there is also flow separation occurring in Willis does not persuasively contradict Dr. Mattingly's testimony.

GE raises substantively Rolls Royce's '719 patent (Ex. 1031), for the first time in its Reply Brief in support of its position that axially movable nozzles were known to be used with a variable pitch fan engine and “the Rolls Royce 719 Patent would have provided a person of ordinary skill in the art with reasonable design modifications for combining Willis and Duesler.” Pet. Reply 19. GE contends that its assertion of the '719 patent, apparently as evidence of what was known in the art, is in response to UTC's arguments in its Patent Owner's Response that the combination of Willis and Duesler would decrease the effective reverse thrust and make the engine louder. *See id.*, and *see* Paper 34, 7 (citing PO Resp. 29, 32–35). During the oral hearing, the parties cited various case law and Board decisions alleged to support their positions on this issue. *See* Tr. 27–29, 4–35.

We do not need to decide if GE's evidence and arguments are contrary to 35 U.S.C. § 312(a). Even

if these contentions are not new argument and evidence, they are not persuasive. The disclosure in the '719 patent relating to the axially moving nozzle forming an opening 76 defining an “additional intake area” may facilitate additional attached air flow into the engine during reverse-thrust, but it fails to adequately explain how this would achieve the express goals of 35% reverse-thrust and noise abatement in the range of 100 PNdB expressed in the Willis short-haul engine design. *See* Ex. 1031, 3:59–4:9. GE fails to point to any persuasive evidence in the '719 patent, or elsewhere, that explains how, even assuming the specific structure of the '719 patent axially moving nozzle somehow provided a known design modification, the axially moving sleeve would meet the fundamental goals of reverse-thrust and noise abatement of the Willis short-haul engine design.

Dr. Abhari’s reply declaration similarly does not provide any persuasive evidence as he echoes GE’s argument, above, stating that flow separation “is a common design concern for turbofan engine inlets.” Ex. 1036 ¶ 6. Dr. Abhari reiterates also GE’s argument that the '719 patent combines an axially moveable nozzle and a variable pitch fan to “produce an effective amount of reverse thrust.” *Id.* ¶ 8. Although we understand from the evidence before us that an axially moveable nozzle and a variable pitch fan may have produced a potentially workable engine, the term “effective amount” is entirely undefined and falls short of a reasonable explanation or analysis as to how one of ordinary skill in the art would be motivated, or led, towards combining an axial translating nozzle with Willis’s variable pitch fan in

order to meet the reverse-thrust requirements for the Willis short-haul engine design.

We are not persuaded that GE's Reply or Dr. Abhari's supplemental declaration provide any additional argument or evidence that one of ordinary skill in the art would have combined Willis and Duesler to meet the claimed invention. Therefore, we need not determine whether or not GE's raising such additional arguments contain new argument or new evidence such as precluded under 35 U.S.C. § 312(a). Accordingly, we DENY UTC's Motion to Strike.

IV. ORDER

For the reasons given, it is ORDERED that

Claims 7–11 of U.S. Patent No. 8,511,605 B2 have not been shown to be unpatentable as obvious over Willis and Duesler, and

Patent Owner's motion (Paper 30) is *denied*.

This is a final decision. Parties to the proceeding seeking judicial review of the decision must comply with the notice and service requirements of 37 C.F.R. § 90.2.

54a

NOTE: This order is nonprecedential
UNITED STATES COURT OF APPEALS
FOR THE FEDERAL CIRCUIT

GENERAL ELECTRIC COMPANY,
Appellant

v.

UNITED TECHNOLOGIES CORPORATION,
Appellee

2017-2497

Appeal from the United States Patent and
Trademark Office, Patent Trial and Appeal Board in
No. IPR2016-00531.

ON PETITION FOR REHEARING EN BANC

Before PROST, Chief Judge, NEWMAN, LOURIE,
MOORE, O'MALLEY, REYNA, WALLACH, TARANTO,
CHEN, and HUGHES, *Circuit Judges**.

PER CURIAM.

ORDER

Appellant General Electric Company filed a
petition for rehearing en banc. A response to the
petition was invited by the court and filed by Appellee
United Technologies Corporation. The petition was
first referred as a petition for rehearing to the panel
that heard the appeal, and thereafter the petition for

* Circuit Judges Dyk and Stoll did not participate.

55a

rehearing en banc was referred to the circuit judges who are in regular active service.

Upon consideration thereof,

IT IS ORDERED THAT:

The petition for panel rehearing is denied.

The petition for rehearing en banc is denied.

The mandate of the court will issue on October 22, 2019.

October 15, 2019

Date

FOR THE COURT

/s/ Peter R. Marksteiner

Peter R. Marksteiner

Clerk of Court

**UNITED STATES CONSTITUTION
ARTICLE III, SECTION 2**

The judicial Power shall extend to all Cases, in Law and Equity, arising under this Constitution, the Laws of the United States, and Treaties made, or which shall be made, under their Authority;—to all Cases affecting Ambassadors, other public Ministers and Consuls;—to all Cases of admiralty and maritime Jurisdiction;—to Controversies to which the United States shall be a Party;—to Controversies between two or more States;— between a State and Citizens of another State,—between Citizens of different States,—between Citizens of the same State claiming Lands under Grants of different States, and between a State, or the Citizens thereof, and foreign States, Citizens or Subjects.

In all Cases affecting Ambassadors, other public Ministers and Consuls, and those in which a State shall be Party, the supreme Court shall have original Jurisdiction. In all the other Cases before mentioned, the supreme Court shall have appellate Jurisdiction, both as to Law and Fact, with such Exceptions, and under such Regulations as the Congress shall make.

The Trial of all Crimes, except in Cases of Impeachment, shall be by Jury; and such Trial shall be held in the State where the said Crimes shall have been committed; but when not committed within any State, the Trial shall be at such Place or Places as the Congress may by Law have directed.

35 U.S.C. § 311**§ 311. Inter partes review**

(a) **IN GENERAL.**—Subject to the provisions of this chapter, a person who is not the owner of a patent may file with the Office a petition to institute an inter partes review of the patent. The Director shall establish, by regulation, fees to be paid by the person requesting the review, in such amounts as the Director determines to be reasonable, considering the aggregate costs of the review.

(b) **SCOPE.**—A petitioner in an inter partes review may request to cancel as unpatentable 1 or more claims of a patent only on a ground that could be raised under section 102 or 103 and only on the basis of prior art consisting of patents or printed publications.

(c) **FILING DEADLINE.**—A petition for inter partes review shall be filed after the later of either—

(1) the date that is 9 months after the grant of a patent; or

(2) if a post-grant review is instituted under chapter 32, the date of the termination of such post-grant review.

35 U.S.C. § 315

§ 315. Relation to other proceedings or actions

* * *

(e) ESTOPPEL.—

(1) PROCEEDINGS BEFORE THE OFFICE.—The petitioner in an inter partes review of a claim in a patent under this chapter that results in a final written decision under section 318(a), or the real party in interest or privy of the petitioner, may not request or maintain a proceeding before the Office with respect to that claim on any ground that the petitioner raised or reasonably could have raised during that inter partes review.

(2) CIVIL ACTIONS AND OTHER PROCEEDINGS.—The petitioner in an inter partes review of a claim in a patent under this chapter that results in a final written decision under section 318(a), or the real party in interest or privy of the petitioner, may not assert either in a civil action arising in whole or in part under section 1338 of title 28 or in a proceeding before the International Trade Commission under section 337 of the Tariff Act of 1930 that the claim is invalid on any ground that the petitioner raised or reasonably could have raised during that inter partes review.

59a

35 U.S.C. § 319

§ 319. Appeal

A party dissatisfied with the final written decision of the Patent Trial and Appeal Board under section 318(a) may appeal the decision pursuant to sections 141 through 144. Any party to the inter partes review shall have the right to be a party to the appeal.

Appeal No. 2017-2497

**IN THE
UNITED STATES COURT OF APPEALS
FOR THE FEDERAL CIRCUIT**

General Electric Company,
Appellant

v.

United Technologies Corporation,
Appellee.

**DECLARATION OF ALEXANDER E. LONG IN
SUPPORT OF GENERAL ELECTRIC
COMPANY'S OPPOSITION TO APPELLEE'S
MOTION TO DISMISS**

I, Alexander E. Long, pursuant to 28 U.S.C. § 1746, make the following declaration based on my own personal knowledge or belief following a reasonable investigation:

1. I am the Chief IP Counsel and General Counsel – Engineering for GE Aviation. GE Aviation is a business unit of General Electric Company, the appellant in the present appeal.

2. GE Aviation (hereinafter “GE”) designs, develops, manufactures, tests, certifies, and supplies turbofan engines for both military applications and the worldwide commercial aviation market. In the commercial space, GE supplies engines to fly on airframes produced by major aircraft providers such as Boeing and Airbus (which in industry parlance are known as “airframers”). As one example, GE’s GE90, which entered service in 1995, is a family of high-

bypass turbofan aircraft engines built for the Boeing 777 airliner.

3. GE supplies aircraft engines itself and through its joint ventures. For example, GE has a long-standing partnership with Safran Aircraft Engines (previously Snecma), a French aerospace engine manufacturer headquartered in Courcouronnes, France. The GE-Safran joint venture is known as CFM International. CFM also designs, tests, certifies, manufactures, and supplies aircraft engines, including the CFM56 and LEAP aircraft engines used on airplanes supplied by Boeing, Airbus, and others.

4. There are three principal original equipment manufacturers of aircraft engines for the worldwide commercial aviation market. They are: (1) GE; (2) Pratt & Whitney Corporation (a business unit of appellee United Technologies Corporation (“UTC”)), based in East Hartford, Connecticut; and (3) Rolls-Royce, headquartered in London, England. GE is UTC’s biggest competitor in the aircraft engine industry. The competition in the aircraft engine market is fierce, for the reasons I explain below.

5. The commercial aircraft engine business operates in a long life-cycle and highly regulated market. Aircraft engines must be specifically designed and certified for specific aircraft. For example, through its joint venture CFM International, GE supplies the LEAP-1A turbofan engine specifically for the Airbus A320 aircraft, which recently entered service in the so-called “narrow-body” market (single-aisle aircraft, capacity of approximately 140-220 passengers, and a range of approximately 2,500-3,500 nautical miles).

6. Turbofan engines and their corresponding aircraft must be certified as airworthy by regulatory authorities such as the Federal Aviation Administration (FAA) or the European Aviation Safety Agency (EASA). The process of designing, developing, testing, and certifying a new aircraft engine can take eight to ten years or longer. Accordingly, once a new engine has been certified with a specific aircraft and goes into service, that engine will typically continue to fly on that aircraft for its full lifespan, subject to normal maintenance, repair and overhaul (MRO) services. In other words, once an engine goes on an aircraft, it will not come off until the airplane is ready to be retired, which can take 25-30 years or more. For example, the GE90 turbofan engine for the Boeing 777 airliner, which entered service over 20 years ago in 1995, continues to fly on that aircraft today.

7. There is an enormous up-front investment required to design, develop, test, certify, and manufacture new aircraft engines. Hundreds of millions (if not billions) of dollars may be spent for a specific engine. Once an engine is selected and certified for a particular aircraft, however, the engine maker may typically expect to receive orders for the engine and corresponding MRO services for years to come, representing billions of dollars in potential revenues.

8. Because of the enormous upfront investment and amount of time required to develop new aircraft engines, new aircraft engine design work necessarily begins years before there is any commercial sale or offer for sale of the final engine. Airframers begin sharing potential specifications (*e.g.*, on thrustclass, performance, weight, etc.) for their next-generation

aircraft many years in advance of any anticipated aircraft/engine sale. Preliminary design work for new aircraft engine designs based on those early specifications must correspondingly begin many years in advance just to meet a prospective date for entry-into-service a decade later.

9. The threat of overly broad, invalid turbofan architecture patents in the aircraft engine space harms GE by impeding its ability to design engines for aircraft makers by creating artificial barriers to the development of innovative new designs. In the aircraft engine industry, overbroad and invalid patents represent competitive threats that need to be reasonably considered during the design process. Such patents necessarily limit design options and innovative solutions for engine designs that build upon old technical concepts well known in the prior art. This puts GE at an unfair competitive and financial disadvantage.

10. UTC has filed for thousands of patents in the aircraft engine space in the past decade. It is GE's policy to challenge what it believes to be overly broad and clearly invalid patents that increase its design costs and stifle its ability to innovate and compete in the aircraft engine market. Since the beginning of 2016, GE has used the U.S. Patent and Trademark Office's *Inter Partes* Review (IPR) process to contest the validity of some of UTC's overly broad patents.

11. To date, GE has filed 25 IPR petitions against UTC's patents. The Patent and Trial Appeal Board ("Board") instituted 17 IPR proceedings, and denied eight. Of those that were denied, three were denied because, in response to the IPR petition, UTC disclaimed all challenged claims, such that there were no longer any challenged claims remaining for

consideration by the Board. In the instituted IPRs, the Board has so far issued Final Written Decisions in 12 of them. In one Final Written Decision, the Board entered an adverse judgment against UTC after UTC disclaimed the only claim at issue following the institution decision. In the other 11 Final Written Decisions, the Board found that some or all of the challenged claims were invalid. UTC has also abandoned 12 related pending patent applications following the filing of GE's IPR petitions.

12. GE believes that the current UTC patent (U.S. Patent No. 8,511,605) that is the subject of this appeal is emblematic of UTC's systematic plan to obtain overly broad and invalid patents covering basic turbofan engine architectures and unfairly stifle competition. The earliest application filing date of the '605 patent is June 2, 2008. The '605 patent will not expire until 2028 at the earliest. The patent describes a turbofan engine having a gear train between the turbine and the fan (colloquially called a "geared turbofan" or "GTF").

13. There are 16 claims in the 605 patent. In claim 1, the sole independent claim, a turbine drives a fan through a gear train. Claims 7-11 depend from claim 1 and add a fan nozzle that is capable of being adjusted to vary the exit area of the nozzle (referred to as a "VAFN"). GE filed two IPR petitions against the claims of the '605 patent. In IPR2016-00531, GE challenged claims 1, 2, and 7-11. In this IPR, GE asserted that its own prior art work, called "QCSEE" and described in a 1979 NASA paper (discussed more below) was anticipatory prior art against claim 1. In IPR2016-00533, GE challenged claims 1-6 and 12-16. Prior to the Board's institution decisions, UTC filed a Disclaimer in Patent Under 37 CFR 1.321(a), a true

and correct copy of which is attached as Exhibit A hereto, in which UTC disclaimed claims 1-6 and 12-14. The Board instituted IPRs of remaining claims 7-11 (in IPR2016-00531) and claims 15-16 (in IPR2016-00533). After the Board's Final Written Decisions in the two IPRs, GE appealed the Board's decision finding claims 7-11 not invalid (the present appeal), and UTC appealed the Board's decision finding claims 15 and 16 invalid (companion appeal 2017-2502).

14. As stated above, claims 7-11 of the '605 patent are directed to a conventional geared turbofan engine with a VAFN. In the mid-1970s, GE designed a geared turbofan engine with a VAFN for NASA, as part of GE's Quiet Clean Short-Haul Experimental Engine (QCSEE) program. NASA published GE's Final Report disclosing the QCSEE geared turbofan VAFN engine in 1979. Exhibit B hereto is a true and correct copy of relevant excerpts of the QCSEE 1979 Report. GE still has some of the QCSEE engines it built at its Cincinnati headquarters. Reproduced below is a picture of one of the QCSEE engines:

[photograph omitted]

15. With respect to the challenged claims in this appeal (as well as those in the companion appeal of claims 15 and 16), GE reserves design options for new engines based on its own previously developed technologies and engine programs. This includes GE's QCSEE geared turbofan VAFN engine. As a matter of technological prudence and good business, GE does not, and cannot, rule out any long-known turbofan architecture that it might have in its "toolkit" of engine options to meet a prospective customer's needs until a final engine is ultimately delivered. The threat of claims 7-11 of the '605

patent, however, impedes GE's ability to consider a geared turbofan VAFN engine for such a new engine design – even though GE already built such an engine approximately 40 years ago. This results in economic harm to GE, by increasing its research, development, and design costs, and competitive harm by limiting GE's ability to compete in the supply of engines to aircraft makers.

16. GE is currently discussing with airframers possible future engine designs for next-generation aircraft applications. The existence of UTC's overly broad and invalid patents, including the '605 patent, restricts GE's design choices for these new engines. It forces GE to expend additional research and development money on designs that do not implicate the '605 patent, even though GE's own history of engine development includes geared turbofan engines with a VAFN, such as the QCSEE.

17. UTC and Pratt & Whitney have a history of threatening the aviation industry with their patent portfolio. UTC sued Rolls-Royce for patent infringement in 2010, filing complaints in both the International Trade Commission and federal district court. Exhibit C is a true and correct copy of an article published by Law360 on November 8, 2010 reporting on UTC's lawsuit.

18. In a June 18, 2017 article published in *Aviation Week*, a true and correct copy of which is attached as Exhibit D, Pratt & Whitney's President Bob Ludec is described as vowing to use any means necessary to protect Pratt & Whitney's investment in geared turbofan engines. Referring to GE Aviation specifically, Mr. Ludec stated that GE Aviation has "3,500 patents they got to get through, so we will see. But we think we are pretty well protected and we plan

to defend our position.” Mr. Leduc also threatened to sue GE’s competitor Rolls-Royce for patent infringement in the same article.

19. A follow-up article from *Aviation Week*, dated June 20, 2017, a true and correct copy of which is attached as Exhibit E, reiterates Mr. Leduc’s vow that Pratt & Whitney “will go all out to use legal means to protect the patents covering the GTF family.”

20. I have reviewed the articles submitted with UTC’s Motion to Dismiss (exhibits 4-6 attached to the Declaration of Patrick Coyne). Those articles concern only one specific engine design in the late 2000s for the then-next generation, now current generation narrow-body Boeing 737 Max and Airbus A320neo aircraft. As explained in those articles, GE chose not to pursue an engine design based on a conventional geared architecture as UTC did, principally for concerns over a lack of reliability of a conventional geared design given the maturity of then-available enabling components.

21. GE’s concerns at the time over reliability have proven valid, as there have been numerous issues with Pratt & Whitney’s PW1100G, its commercial engine using a specific gear train mechanism. Exhibit F hereto is a true and correct copy of a July 27, 2017 article from the *Hartford Courant*, reporting on the serious issues Airbus has experienced with the engine. Discussing the engine, Airbus’s CEO is quoted as saying: “There are just too many maturity issues on this engine.... That is frustrating for us, that’s frustrating for the customers. We have too many removals of engines on aircraft that are in service. The situation for us all is very unsatisfactory.” Similarly, Exhibit G is a true and correct copy of an article from AINOnline dated April

27, 2017, titled *Pratt PW1100G Performance Not Satisfactory, Says Airbus CFO*. This article also reports on the problems plaguing Airbus's adoption of the PW1100G engine.

22. While GE chose for business risk reasons in the late 2000s not to pursue an engine with a gear train for the narrow-body line of aircraft, it does not mean that GE Aviation has chosen to permanently forego any and all future engine designs that may use a speed reduction mechanism, including those that might be suitably paired with a VAFN. Instead, GE considers its prior art engine designs, including its QCSEE design, as valid options on which to base future engine designs, including those which GE is currently discussing with airframers for next-generation aircraft applications.

23. I understand that as a result of the Board's Final Written Decision regarding claims 7-11 of the '605 patent, GE is estopped from challenging the validity of those claims on any ground that GE raised or reasonably could have raised during the IPR. Absent the estoppel, GE would otherwise continue to challenge the validity of claims 7-11 of the '605 patent on the same grounds as those asserted in the IPR, or on similar grounds.

24. Pursuant to 28 U.S.C. § 1746, I declare under penalty of perjury that the foregoing is true and correct.

Executed on: January 16, 2018

By: /s/ Alexander E. Long
Alexander E. Long

Appeal No. 2017-2497

**IN THE
UNITED STATES COURT OF APPEALS
FOR THE FEDERAL CIRCUIT**

General Electric Company,
Appellant

v.

United Technologies Corporation,
Appellee.

**SUPPLEMENTAL DECLARATION OF
ALEXANDER E. LONG IN SUPPORT OF
GENERAL ELECTRIC COMPANY'S
STANDING**

I, Alexander E. Long, pursuant to 28 U.S.C. § 1746, make the following declaration based on my own personal knowledge or belief following a reasonable investigation:

1. I am the Chief IP Counsel and General Counsel – Engineering for GE Aviation. GE Aviation is a business unit of General Electric Company, the appellant in the present appeal. I previously submitted a declaration in this appeal in response to Appellee United Technologies Corporation's ("UTC") motion to dismiss the appeal for lack of standing. *See* Dkt. No. 36 at 29-164. I am submitting this supplemental declaration in response to the Court's November 8, 2018 *Sua Sponte* Order (Dkt. No. 61).

2. As Chief IP Counsel and General Counsel for Engineering for GE Aviation ("GE"), I work closely with the company's engineering and business leaders

who are the responsible decision-makers for the research, design, development, and manufacturing of GE's turbofan engines. This includes the turbofan engines that GE and Safran S.A. design and manufacture together as part of their joint venture CFM International ("CFM"). I provided additional details concerning CFM in my previous declaration at paragraph 3.

3. The GE engineering and business leaders with whom I work regularly interface with airplane makers ("airframers"), who are the principal customers for GE's (and CFM's) engines. The airframers explain to GE their needs and requirements for turbofan engines, to enable GE to provide competitive offerings that will satisfy the airframers' requirements. In my capacity as Chief IP Counsel and General Counsel for Engineering, I frequently advise GE's engineering and business leaders on the legal risks and requirements associated with GE's decisions concerning the research, design, development, and manufacturing of engines for such airframers.

4. As I stated in my previous declaration (*see* paragraphs 16 and 22), GE has in the past and is currently discussing with airframers possible future engine designs for next-generation aircraft applications. As one example, GE's engineering and business leaders have been in discussions with **[redacted]** since at least **[redacted]** regarding a next generation aircraft now referred to as **[redacted]**. As part of this multi-year process, **[redacted]** submitted several requests for information ("RFIs") to GE (as part of CFM), as well as to UTC and Rolls-Royce. **[redacted]** RFIs set forth **[redacted]** potential needs and requirements

for an engine suitable for [redacted] aircraft and requested GE to supply information regarding a suitable engine design.

5. As part of [redacted] RFI process for the [redacted], GE provided information to [redacted] regarding various engine architectures potentially meeting [redacted] requirements. One of the engine architectures that GE investigated and identified to [redacted] was an engine that [redacted]. GE also investigated and discussed with [redacted] the possible use of [redacted], which would potentially implicate UTC's 605 Patent (the subject of this appeal). GE and [redacted] also discussed [redacted] "direct drive" (referred to as "DD") architectures, which has been the conventional architecture employed by GE engines currently in service.

6. GE's research and investigation into the possible supply of an [redacted] or a [redacted] DD engine for the [redacted] application was memorialized by [redacted] in Exhibit I, attached to this Supplemental Declaration, which is a true and correct copy of excerpts of a Meeting Summary of a meeting between [redacted] and CFM that occurred [redacted]. [redacted] provided this Meeting Summary to GE. Portions of the excerpted Meeting Summary that are not relevant to the issues in this appeal have been redacted. At GE's request, [redacted] agreed that this excerpt of the Meeting Summary, as redacted, could be provided by GE as part of my declaration under the condition that it will be filed as a confidential document and not made publicly available. [redacted] has indicated to me that Exhibit I, as well as the information I have provided in this declaration concerning GE's

discussions with [redacted], are considered by [redacted] to be proprietary and confidential to [redacted], and any disclosure of which to the public would cause [redacted] competitive harm.

7. The unredacted text on the second page of Exhibit I memorializes [redacted] request that GE “[r]efine installations of . . . [redacted] engines,” “[p]rovide definition for . . . [redacted],” and “[i]nvestigate benefits, refine technology plans [redacted],” as part of the RFI process for [redacted]. In response to [redacted] request, GE expended time and money researching and further developing [redacted] proposal for [redacted], including [redacted]—again, which would potentially implicate the 605 Patent.

8. On January 29, 2016, GE submitted two petitions for *Inter Partes* Review (“IPR”) of the 605 Patent. On June 26, 2017, the Patent Trial and Appeal Board entered its Final Written Decisions in the 605 Patent IPRs. In the IPR that is the basis for GE’s appeal, the Board held that GE had not shown that claims 7-11 of the 605 Patent were invalid. During this period, the RFI process for the [redacted] was still in process.

9. In mid-2018, GE (through CFM), UTC, and Rolls-Royce each submitted a final formal engine proposal to [redacted]. GE ultimately [redacted] submitted an engine proposal based on a direct-drive (DD) architecture. However, the [redacted] RFI process demonstrates that, in order to maintain its competitive position in the market and respond to its customers’ needs, GE must consider engine designs which—as discussed with [redacted] RFI process—include designs which may implicate the 605 Patent.

73a

Pursuant to 28 U.S.C. § 1746, I declare under penalty of perjury that the foregoing is true and correct.

Executed on: November 27, 2018

By: /s/ Alexander E. Long
Alexander E. Long