

App. 1

NOTE: This order is nonprecedential.

**United States Court of Appeals
for the Federal Circuit**

VOLTSTAR TECHNOLOGIES, INC.,
Appellant

v.

SUPERIOR COMMUNICATIONS, INC.,
Appellee

2018-2093

Appeal from the United States Patent and Trade-
mark Office, Patent Trial and Appeal Board in No.
IPR2017-00067.

ON MOTION

Before DYK, REYNA, and TARANTO, *Circuit Judges*.
TARANTO, *Circuit Judge*.

ORDER

(Filed Nov. 6, 2018)

Voltstar Technologies, Inc. moves to vacate the fi-
nal decision of the Patent Trial and Appeal Board and
remand to the Board for it to dismiss the underlying

App. 2

inter partes review (IPR) for lack of jurisdiction. Superior Communications, Inc. opposes the motion.

In February 2013, Superior appears to have been served with a complaint asserting that it infringed Voltstar’s U.S. Patent No. 7,910,833. The district court dismissed the complaint without prejudice, following the parties’ joint stipulation requesting such relief. In 2016, Superior filed a petition for IPR of the patent. The Board instituted review over Voltstar’s objection that the petition was untimely under 35 U.S.C. § 315(b) because the IPR was filed more than one year after [Superior] was served with a complaint alleging infringement of the challenged patent.

In April 2018, the Board issued its final written decision in the case. *Superior Commc’ns, Inc. v. Voltstar Techs., Inc.*, IPR2017-00067, 2018 WL 1902040 (PTAB Apr. 20, 2018). It concluded that Superior had shown by a preponderance of the evidence that the challenged claims were unpatentable on obviousness grounds. And it again rejected Voltstar’s contention that the petition was untimely, explaining that “the effect of a voluntary dismissal without prejudice is to render the prior action a nullity,” and hence not subject to the § 315(b) time bar. *Id.* at *6.

We agree with Voltstar that, contrary to the Board’s conclusion, these facts make § 315(b)’s time bar applicable, and hence “[a]n [IPR] may not be instituted.” § 315(b). As we recently explained in in [sic] *Click-to-Call Technologies, LC v. Ingenio, Inc.*, 899 F.3d 1321 (Fed. Cir. 2018) (en Banc in part), nothing in § 315(b) makes relevant whether the February 2013

App. 3

complaint was eventually dismissed voluntarily and without prejudice. All that matters, under its plain terms, is that the IPR is “filed more than 1 year after the date on which the petitioner, real party in interest, or privy of the petitioner is served with a complaint alleging infringement of the patent.”

Superior asserts now there is no proof that it was served. However, the Board noted in its final written decision that “Petitioner d[id] not dispute that it was served with a complaint alleging infringement of the ‘833 patent more than one year prior to filing the Petition in the instant proceeding.” *Superior*, 2018 WL 1902040 at *6. The court therefore deems it appropriate to terminate the appeal and remand to the Board with instructions to vacate the underlying *inter partes* review due to application of § 315(b).

Accordingly,

IT IS ORDERED THAT:

(1) The motion is granted. The appeal is terminated, and the IPR is remanded to the Board to vacate the underlying *inter partes* review.

(2) Each side shall bear its own costs.

Nov. 6, 2018
Date

FOR THE COURT
/s/ Peter R. Marksteiner
Peter R. Marksteiner
Clerk of Court

ISSUED AS A MANDATE: November 6, 2018

App. 4

Trials@uspto.gov
Tel: 571-272-7822

Paper No. 34
Entered: April 20, 2018

UNITED STATES PATENT
AND TRADEMARK OFFICE

BEFORE THE PATENT TRIAL AND APPEAL BOARD

SUPERIOR COMMUNICATIONS, INC.,
Petitioner,

v.

VOLTSTAR TECHNOLOGIES, INC.,
Patent Owner.

Case IPR2017-00067
Patent 7,910,833 B2

Before MATTHEW R. CLEMENTS, CHRISTA P. ZADO,
and MONICA S. ULLAGADDI, *Administrative Patent
Judges.*

ZADO, *Administrative Patent Judge.*

FINAL WRITTEN DECISION

35 U.S.C. § 318(a)

37 C.F.R. § 42.73

I. INTRODUCTION

We have authority to hear this *inter partes* review under 35 U.S.C. § 6. This Final Written Decision (“Final Written Decision”) is issued pursuant to 35 U.S.C. § 318(a) and 37 C.F.R. § 42.73. For the reasons

App. 5

discussed herein, we determine that Superior Communications, Inc. (“Petitioner”)¹ has shown, by a preponderance of the evidence, that claims 4, 11, 12, 16–18, and 20–22 of U.S. Patent No. 7,910,833 B2 (Ex. 1001, “the ’833 patent”) are unpatentable. *See* 35 U.S.C. § 316(e); 37 C.F.R. § 42.1(d).

A. Procedural History

Petitioner filed a Petition for *inter partes* review of claims 1–4, 6–12, 16–18, 20–22, and 56–58 of the ’833 patent (Paper 1, “Petition” or “Pet.”) and Voltstar Technologies, Inc. (“Patent Owner”)² subsequently filed a Re-Filed Preliminary Response (Paper 10, “Preliminary Response” or “Prelim. Resp.”).³ Petitioner thereafter filed an authorized Reply to Patent Owner’s [Preliminary] Response. Paper 11. On April 25, 2017, we instituted an *inter partes* review to determine whether claims 4, 11, 12, 16–18, and 20–22 of the ’833 patent (“the Challenged Claims”) are unpatentable under 35 U.S.C. § 103(a) as obvious over the following combinations: claim 4 over Sakamoto⁴

¹ Petitioner identifies as the real party in interest, pursuant to 37 C.F.R. § 42.8, Superior Communications, Inc. Pet. 1.

² Patent Owner identifies as real party in interest, pursuant to 37 C.F.R. § 42.8, Voltstar Technologies, Inc. Paper 5, 1.

³ Patent Owner previously filed a preliminary response on January 12, 2017 (Paper 7), which is superseded by the filing of an authorized re-filed preliminary response (Paper 10).

⁴ Patent Application Disclosure JP 2003-284342 (Ex. 1009) (“Sakamoto”). Exhibit 1009 includes an English translation at pages 8–21.

App. 6

and Odaohhara;⁵ claims 11, 12, 17, 18, 20, and 21 over Noguchi⁶ and Huang,⁷ and over Noguchi, Huang, and Suzuki;⁸ claim 16 over Noguchi, Huang, and Byun,⁹ and over Noguchi, Huang, Suzuki, and Byun; and claim 22 over Noguchi, Sakamoto, and Odaohhara, and over Noguchi, Suzuki, Sakamoto, and Odaohhara. Paper 14, 33–34 (“Institution Decision” or “Inst. Dec.”).

After institution, Patent Owner filed a Response. Paper 18 (“Response” or “PO Resp.”). Petitioner thereafter filed a Reply to Patent Owner’s Response. Paper 26 (“Reply”).

No oral hearing took place in this proceeding. The parties stipulated that there would be no oral hearing in this proceeding, unless requested by the Board. Paper 31. The Board did not request oral hearing.

B. Additional Proceedings

Pursuant to 37 C.F.R § 42.8(b)(2), the parties have indicated the following. Petitioner indicates Patent Owner previously filed a district court action against

⁵ U.S. Patent No. 6,986,067 B2 (Ex. 1010) (“Odaohhara”).

⁶ Patent Application Disclosure JP 2002-199612 (Ex. 1011) (“Noguchi”). Exhibit 1011 includes an English translation at pages 15–36.

⁷ U.S. Patent Publication No. 2002/0115480 A1 (Ex. 1013) (“Huang”).

⁸ U.S. Patent No. 6,489,725 B1 (Ex. 1012) (“Suzuki”).

⁹ Public Patent Application KR 10-2006-0008699 (Ex. 1014) (“Byun”). Exhibit 1014 includes an English translation at pages 5–8.

App. 7

non-parties to this proceeding asserting the '833 patent on February 29, 2012: *VoltStar Technologies, Inc. v. AT&T Inc. et al.*, Case No. 2:12-cv-00082-JRG (E.D. Tex.). Pet. 3. Petitioner also indicates Patent Owner subsequently filed a district court action against Petitioner on February 1, 2013, asserting the '833 patent: *VoltStar Technologies, Inc. v. Superior Communications*, Case No. 2:13-cv-00097-JRG (E.D. Tex.). Pet. 3. On October 3, 2013, both district court actions were dismissed without prejudice at the parties' request, pursuant to Federal Rule of Civil Procedure 41(a). *Id.* at 3–4; *see also* Ex. 1008 (dismissal order).

Also, on September 14, 2012, Petitioner filed a petition requesting *inter partes* reexamination of the '833 patent, Reexamination Control No. 95/002,365. Pet. 1; *see also* Ex. 1020 (request for reexamination). On August 2, 2013, in the reexamination proceeding, the Examiner issued a Right of Notice of Appeal rejecting claims 1–23 and 56–58 of the '833 patent, and finding claims 24–27 and 33–37 patentable. *Id.* at 1–2 (citing Ex. 1003, 3). Petitioner appealed the Examiner's validity findings in the reexamination, and Patent Owner cross-appealed the Examiner's invalidity findings, to the Board. Pet. 2. On December 10, 2014, the Board issued a Corrected Decision on Appeal in which the Board, in pertinent part, affirmed the rejection of claims 1–3, and rejected claims 6–10 and 56–58 on new grounds. *Id.* (citing Ex. 1004, 71–72, "Decision on Appeal"). Petitioner appealed the Board's decision to the United States Court of Appeals for the Federal Circuit ("Federal Circuit"), Case No. 2016-1204 (*id.*), and

App. 8

Patent Owner filed a cross-appeal, Case No. 2016-1205, which Patent Owner later dismissed voluntarily (Paper 13, 1). The Federal Circuit issued its decision in the appeal on February 13, 2017, after the filing of the Petition in the instant proceeding, affirming the Board's decision pursuant to Federal Circuit Rule 36. Paper 13, 1; *see also* Ex. 3001 (Federal Circuit decision). On November 3, 2017, the U.S. Patent and Trademark Office ("the Office") issued a reexamination certificate for the '833 patent. Paper 28, 1; *see also* Ex. 3002 (reexamination certificate). The reexamination certificate states the patentability of the claims challenged in this proceeding, claims 4, 11, 12, 16–18, and 20–22, is confirmed. Paper 28, 1; Ex. 3002.

Petitioner also indicates Patent Owner filed a district court action against Petitioner asserting the '833 patent on October 19, 2016 (after the Petition was filed in the instant proceeding), *VoltStar Technologies, Inc. v. AT&T Mobility, LLC et al.*, Case No. 2:16-cv-01181-JRG (E.D. Tex.), and further indicates the district court stayed the action until August 1, 2017. Paper 13, 1–2. Patent Owner indicates the court further stayed the action until February 1, 2018. PO Resp. 1.

Petitioner also indicates *inter partes* reexamination proceedings regarding patents related to the '833 patent have concluded, namely reexamination of U.S. Patent No. 8,242,359, Reexamination Control No. 95/002,374, and of U.S. Patent No. 7,960,648, Reexamination Control No. 95/002,378. Pet. 2–3.

App. 9

C. The '833 Patent

The '833 patent was filed on May 27, 2008. Ex. 1001, [22]. The '833 patent does not claim priority to any earlier filed applications. *See generally* Ex. 1001. Therefore, we determine the earliest possible priority date of the '833 patent is May 27, 2008.

The '833 patent generally relates to a power device, such as an alternating current (“AC”) adapter, for charging portable electronic devices. Ex. 1001, Abstract. More specifically, the power device includes a power shut off feature to prevent the power device from continuing to draw power (i.e., phantom load) from an AC outlet when the electronic device becomes fully charged or is removed from the power device. *Id.* at 1:6–11, 1:63–2:3.

The '833 patent describes, for example, power device 10, depicted in Figures 1–2. Figures 1 and 2 are reproduced below:

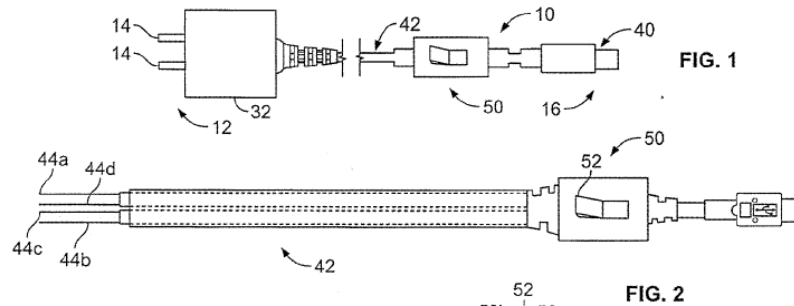

Ex. 1001, Figs. 1, 2. Figure 1 depicts power device 10 having first end 12 comprising prongs 14 that are inserted into a power outlet that provides electrical power to power device 10. *Id.* at 6:57–61. Second end

App. 10

16 is depicted as comprising connector 40 for connecting with electronic device 20, such as a cell phone, in order to recharge device 20. *Id.* at 6:61–7:3. Depicted in Figure 2, switch assembly 50 comprises rocker or toggle throw 52 for switching power device 10 between an “on” state in which power may be delivered to device 20, and an “off” state in which power draw is zero or negligible, e.g., when device 20 is fully charged or disconnected from power device 10. *Id.* at 6:42–47, 7:37–46. Power device 10 also includes circuitry 30, not shown in Figures 1 and 2, for converting input power received at prongs 14 into output power delivered to electronic device 20. *Id.* at 7:4–12, Fig. 8. The ’833 patent discloses that “[i]n order to be a true ‘zero-energy’ device the power input (i.e., AC input) to the power device must be cut.” *Id.* at 2:53–54. Moreover, the point at which the circuit in the power device circuitry is opened is important because “[t]he portion of a charger/adaptor that is most directly responsible for power draw or phantom load are a switcher IC chip 210 (see FIG. 8), a transformer T (see FIG. 8), and components downstream therefrom.” *Id.* at 8:20–35. Accordingly, in a preferred embodiment, transformer T is downstream of switch terminals 50a and 50b, and therefore unable to draw power when switch terminals 50a and 50b are open, i.e., power device 10 is in an “off” state. *Id.* at 8:5–35.

D. Challenged Claims of the ’833 Patent

Of the challenged claims noted above, claim 11 is independent, and claims 12, 16–18, and 20–22 depend

App. 11

either directly or indirectly therefrom. Claim 4 depends from a claim not challenged in this proceeding, claim 1.

Claim 11 is reproduced below:

11. A power device for supplying power to a portable rechargeable electronic device, the power device comprising:

a first portion for receiving electrical input power from a source, the input having an input voltage;

a second portion for delivering electrical output power to the electronic device, the output power having an output voltage;

circuitry for converting the input power voltage to the output power voltage and for determining an “off” state of the circuitry;

a connector located on the second portion and removably connectable with the electronic device; and

a switch assembly having powered terminals, the switch assembly responsive to movement or at least a movable portion thereof to electrically connect the terminals and to provide an output signal to activate the circuitry to the “on” state,

wherein the circuitry automatically turns the circuitry to the “off” state, the circuitry drawing no power when in the “off” state.

Ex. 1001, 12:26–45.

II. DISCUSSION

A. *Level of Ordinary Skill in the Art*

In determining whether an invention would have been obvious under 35 U.S.C. § 103 at the time it was made, we must first resolve the level of ordinary skill in the pertinent art at the time of invention. *Graham v. John Deere Co.*, 383 U.S. 1, 17 (1966). Factors that may be considered in determining the level of ordinary skill in the art include, but are not limited to, the types of problems encountered in the art, the sophistication of the technology, and educational level of active workers in the field. *In re GPAC, Inc.*, 57 F.3d 1573, 1579 (Fed. Cir. 1995).

Petitioner asserts that a person of ordinary skill in the art (“PHOSITA”) in “technical areas relevant to” the ’833 patent would have had “a Bachelor of Science degree in Electrical Engineering or a closely-related field. Ex. 1019 ¶33. The PHOSITA would also have a minimum of one to two years of professional experience in the development of electronic power devices or other equivalent experience.” Pet. 13 (citing the Declaration of Dr. Mark Horenstein, Ex. 1019 ¶ 33). Neither Patent Owner nor Dr. John M. Tobias proffers what they regard as the level of ordinary skill in the pertinent art.

For purposes of our determination below, we determine the level of ordinary skill in the art with respect to the ’833 patent is consistent with the assessment provided by Dr. Horenstein, which Patent Owner does not dispute. Accordingly, we adopt the level of ordinary

skill in the art asserted by Petitioner. Also, we are guided by the level of ordinary skill in the art reflected by the prior art of record. *Okajima v. Bourdeau*, 261 F.3d 1350, 1355 (Fed. Cir. 2001).

B. Claim Construction

In an *inter partes* review, claim terms in an unexpired patent are interpreted according to their “broadest reasonable construction in light of the specification of the patent” in which they appear. 37 C.F.R. § 42.100(b); *see also* *Cuozzo Speed Techs., LLC v. Lee*, 136 S. Ct. 2131, 2141–46 (2016). We interpret claim terms using “the broadest reasonable meaning of the words in their ordinary usage as they would be understood by one of ordinary skill in the art, taking into account whatever enlightenment by way of definitions or otherwise that may be afforded by the written description contained in the applicant’s specification.” *In re Morris*, 127 F.3d 1048, 1054 (Fed. Cir. 1997). “Under a broadest reasonable interpretation, words of the claim must be given their plain meaning, unless such meaning is inconsistent with the specification and prosecution history.” *Trivascular, Inc. v. Samuels*, 812 F.3d 1056, 1062 (Fed. Cir. 2016).

Petitioner proposes a construction for the term “output signal.” Pet. 14–15. Patent Owner does not dispute Petitioner’s proposed construction, nor does Patent Owner propose any other terms for construction, except to argue that we are bound by the Federal Circuit’s *per curiam* affirmance of the Board’s Decision on

App. 14

Appeal with regard to the reexamination of the '833 patent. PO Resp. 1–2. We determine no claim terms need to be construed expressly, except for as provided below, because the parties' arguments do not otherwise raise any controversy necessitating construction. *See Vivid Techs., Inc. v. Am. Sci. & Eng'g, Inc.*, 200 F.3d 795, 803 (Fed. Cir. 1999) (holding that claim terms need only be interpreted to the extent necessary to resolve the controversy).

Patent Owner argues “[t]his Board has already construed certain terms and this Board’s decision has been affirmed (*per curiam*) by the United States Court of Appeals for the Federal Circuit.” PO Resp. 1. Patent Owner does not identify specific claim terms in the Challenged Claims. *Id.* at 1–2. Patent Owner states only that, in the Decision on Appeal, the Board construed “converting [voltage] as being narrower than altering a signal and a capacitive filter is not a converter,” and the Board determined “the phrase ‘draws no power in the off state’ refers to power on the order of microwatts or less.” *Id.*

1. “converting [voltage]”

With regard to converting a voltage, claim 11 of the '833 patent recites “circuitry for *converting* the input power voltage to the output power voltage for determining an ‘off’ state of the circuitry.” Ex. 1001, 12:33–35 (emphasis added). The issue in the Decision on Appeal was whether smoothing or filtering out noise from incoming voltage, performed by a capacitor in the

applicable prior art reference, was reasonably interpreted as *converting* a voltage. Decision on Appeal at 16, 20. The Decision on Appeal states the determination is limited to “addressing the question of whether Yang’s capacitive filter may be reasonably interpreted as ‘converting electrical power voltage,’ as recited by independent claim 11.” *Id.* at 20. In this proceeding, Petitioner neither relies on a capacitive filter nor argues smoothing or filtering satisfies the “converting” limitation. Petitioner relies on “a common AC/DC converter” that converts AC power to direct current (“DC”) power. Pet. 40–41.

The parties do not raise any controversy in this proceeding as to whether an AC/DC converter satisfies the limitation “circuitry for converting the input power voltage to the output power voltage,” as recited in claim 11. The Decision on Appeal acknowledges AC to DC power conversion is within the scope of the claim term “converting,” stating “we need not [determine] whether the claim term ‘converting’ is exclusively limited to converting AC to DC power.” Ex. 1004, 20; *see also id.* at 9–10 (“[Patent] Owner discloses a charger that plugs into an AC outlet and converts AC voltage to DC voltage in order to power a DC electronic device, such as a cellular phone (e.g., ’833 Patent, Background and Summary sections”). The ’833 patent specification supports a determination that “converting” includes converting AC power to DC power. *See, e.g.,* Ex. 1001, 1:25–26 (“alternating current with an input voltage is received and converted to direct current”).

In view of the foregoing, the construction of “converting [voltage]” in the Decision on Appeal does not impact this Final Written Decision. We determine that converting AC power to DC power, both of which inherently have associated voltage, is within the scope of this claim term. This claim term need not be construed further for purposes of this Final Written Decision.

2. “[draws/drawing] no [input] power
[when] in the ‘off’ state”

Independent claim 1 (from which challenged claim 4 depends) recites “draws no input power in the ‘off’ state,” and independent claim 11 recites “drawing no power when in the ‘off’ state.” Ex. 1001, 11:52–53, 12:44–45. Patent Owner argues these phrases were construed in the Decision on Appeal to mean power is “on the order of microwatts or less.” PO Resp. 2 (citing Ex. 1004, 26, 29). The Decision on Appeal relies on the ’833 patent specification, and states the specification “provides an objective standard for what constitutes ‘no input power.’ The Specification explains that when the power is cut, ‘the power draw is zero or negligible (i.e., measured in microwatts).’” Ex. 1004, 26 (citing Ex. 1001, 6:49–50[]). The parties do not dispute that the phrase “draws no power in the off state” refers to power that is on the order of microwatts or less. *See, e.g.*, Reply 1. The parties do not otherwise raise any controversy concerning the construction of this claim term. *See, e.g.*, Reply 1, 19–21, 24–25. We, therefore, determine this claim term need not be construed further for purposes of this Final Written Decision.

C. Principles of Law

To prevail in its challenges to the patentability of the claims, Petitioner must prove its propositions of unpatentability by a preponderance of the evidence. 35 U.S.C. § 316(e); 37 C.F.R. § 42.1(d). Also,

Section 103(a) forbids issuance of a patent when “the differences between the subject matter sought to be patented and the prior art are such that the subject matter as a whole would have been obvious at the time the invention was made to a person having ordinary skill in the art to which said subject matter pertains.”

KSR Int’l Co. v. Teleflex Inc., 550 U.S. 398, 406 (2007) (quoting 35 U.S.C. § 103).

D. 35 U.S.C. § 315(e)

Patent Owner contends Petitioner is estopped from bringing this *inter partes* review under 35 U.S.C. § 315(e) on grounds that Petitioner has failed to “explain why the ‘new’ prior art [asserted in the Petition] could not have reasonably been located earlier and used in the prior reexamination” of the ’833 patent filed by Petitioner. PO Resp. 3–8. Section 315(e)(1) of title 35 of the United States Code states:

The petitioner in an *inter partes* review of a claim in a patent under this chapter *that results in a final written decision under section 318(a)*, or the real party in interest or privy of the petitioner, may not request or maintain a

proceeding before the Office with respect to that claim on any ground that the petitioner raised or reasonably could have raised during that *inter partes* review.

(Emphasis added). The language of the statute makes clear § 315(e) applies to grounds the petitioner raised or reasonably could have raised during an “*inter partes* review . . . that results in a final written decision under 35 U.S.C. § 318(a).” The statute does not refer to grounds that were raised or reasonably could have been raised during *reexamination*. Because the prior proceeding was a reexamination proceeding under pre-AIA 35 U.S.C. § 311, not an *inter partes* review under post-AIA 35 U.S.C. § 311, and did not result in a final written decision under § 318(a), Petitioner is not estopped under § 315(e) from bringing this *inter partes* review.

Also, in the Response, Patent Owner requests disqualification of Petitioner’s counsel of record in this proceeding, Andrew S. Flior, and his law firm, Snell & Wilmer L.L.P., on grounds that Mr. Flior has provided substantive testimony regarding a disputed issue in this proceeding, namely, the reasonableness of Petitioner’s prior art searches with regard to reexamination of the ’833 patent. PO Resp. 13–14. As an initial matter, the relief Patent Owner requests should have been made in the form of an authorized motion. *See* 37 C.F.R. § 42.20(a) (“Relief, other than a petition requesting the institution of a trial, must be requested in the form of a motion.”). Patent Owner did not request, nor did we authorize, a motion to disqualify Petitioner’s

counsel. Section 42.20(b) of title 37 of the Code of Federal Regulations provides “[a] motion will not be entered without Board authorization.” *See also* 37 C.F.R. § 42.120(a) (“A patent owner may file a response to the petition addressing any ground for unpatentability not already denied.”). Therefore, Patent Owner’s request to disqualify Petitioner’s counsel of record is denied.

In any event, even if we did not deny the motion on procedural grounds, as Petitioner points out, Patent Owner’s request is moot. Reply 10. Mr. Flior’s testimony relates to arguments we need not, and do not, address regarding whether Petitioner is estopped under 35 U.S.C. § 315(e) from bringing this *inter partes* review. Petitioner is not estopped under 35 U.S.C. § 315(e) for the reasons explained above. Because we do not rely on or reference Mr. Flior’s testimony in our Final Written Decision, Patent Owner’s unauthorized request to disqualify Petitioner’s counsel would have been denied as moot.

E. 35 U.S.C. § 315(b)

In the Preliminary Response, Patent Owner asserted we should deny institution of *inter partes* review pursuant to 35 U.S.C. § 315(b) because Petitioner filed the Petition in the instant proceeding more than one year after it was served with a complaint (in 2013) alleging infringement of the ’833 patent. Prelim. Resp. 8–13. We addressed this issue in our Institution Decision, and determined the complaint filed in 2013 does not give rise to a statutory bar under § 315(b) because

it was subsequently voluntarily dismissed without prejudice. Inst. Dec. 8–11. Patent Owner “seeks reconsideration during the ‘merits’ portion of these proceedings based on additional facts and authority.” PO Resp. 8. Petitioner asserts Patent Owner does not raise additional authority or additional facts. Reply 9–10.

Section 315(b) provides that:

An inter partes review may not be instituted if the petition requesting the proceeding is filed more than 1 year after the date on which the petitioner, real party in interest, or privy of the petitioner is served with a complaint alleging infringement of the patent.

35 U.S.C. § 315(b). Patent Owner alleges a privy of Petitioner, AT&T,¹⁰ was served with a complaint on or about February 29, 2012 and Petitioner was served with a complaint on or about February 1, 2013. PO Resp., 9; *see also* Prelim. Resp. 8. Petitioner does not dispute that it was served with a complaint alleging infringement of the ’833 patent more than one year prior to filing the Petition in the instant proceeding. Pet. 3–5. Petitioner argues, however, that the instant proceeding is not barred under § 315(b) because the district court action resulting from the earlier-filed complaint was dismissed without prejudice pursuant to Federal Rule of Civil Procedure 41(a), leaving the

¹⁰ Patent Owner adduces insufficient evidence that AT&T is a privy of Petitioner. In any event, the action against AT&T was consolidated with the action against Petitioner (PO Resp.), and both actions were dismissed, in a single consolidated order, without prejudice (Ex. 1008).

parties “as though the action had never been brought.” Pet. 5 (citing *Ariosa Diagnostics v. Isis Innovation Ltd.*, Case IPR2012-00022, slip op. at 17 (PTAB Sept. 2, 2014) (Paper 166)); *see also* Ex. 1008 (dismissal order). As we have noted in previous Board decisions, the “Federal Circuit has consistently interpreted the effect of such dismissals as leaving the parties as though the action had never been brought.” *Oracle v. Click-to-call*, Case IPR2013-00312, slip op. at 17 (PTAB Oct. 30, 2013) (Paper 26) (precedential); *Macauto U.S.A. v. Bos GmbH & KG*, Case IPR2012-00004, slip op. at 15 (PTAB Jan. 24, 2013) (Paper 18) (citing *Graves v. Principi*, 294 F.3d 1350, 1356 (Fed. Cir. 2002); *Bonneville Assocs., Ltd. P’ship v. Baram*, 165 F.3d 1360, 1364 (Fed. Cir. 1999)). Because the effect of a voluntary dismissal without prejudice is to render the prior action a nullity, such action does not give rise to a statutory bar under 35 U.S.C. § 315(b).

Patent Owner attempts to distinguish the present case on grounds that the parties entered into an agreement (Tolling Agreement, Ex. 2010), as a result of the district court action, in which Patent Owner gave away certain rights. Prelim. Resp. 8–13; PO Resp. 10–13. Patent Owner argues that it is obligated under the Tolling Agreement to terms that never would have been imposed on it had the district court action never been brought. Prelim. Resp. 12–13; PO Resp. 10–13. Patent Owner also argues that the dismissal, when taken together with the Tolling Agreement, amounts to dismissal with prejudice as to the rights of Petitioner because the Tolling Agreement prevents Petitioner

from seeking damages in district court that it would have otherwise been entitled to seek. PO Resp. 10–11. Even assuming *arguendo* that the parties never would have agreed to the terms of the Tolling Agreement absent the district court action, the Tolling Agreement does not change the *de jure* legal effect of the dismissal, which dismisses “all claims, counterclaims, and affirmative defenses asserted in th[e] litigation [] without prejudice.” Ex. 1008. Patent Owner directs us to no authority holding that a contractual agreement between private parties can alter the legal effect of a voluntary dismissal without prejudice. Nor do we consider the Board’s decisions cited by Patent Owner to mandate a different outcome. In *LG Electronics, Inc. v. Mondis Technology Ltd.*, the complaint was not dismissed without prejudice as to all claims. In particular, the claims with respect to computer monitors were dismissed *with* prejudice. *LG Elecs., Inc. v. Mondis Tech. Ltd.*, Case IPR2015-00937, slip op. at 6 (PTAB Sept. 17, 2015) (Paper 8). In the present proceeding, by contrast, all claims in the district court action were dismissed *without* prejudice. Ex. 1008. In *Histologics, LLC v. CDx Diagnostics, Inc.*, the patent infringement claims of the dismissed action were consolidated into another district court action where the parties continued to litigate those claims. *Histologics, LLC v. CDx Diagnostics, Inc.*, Case IPR2014-00779, slip op. at 5 (PTAB Sept. 12, 2014) (Paper 6). Again, that is not the case here.

In sum, notwithstanding the Tolling Agreement, we determine that the complaint filed in 2013 and

subsequently voluntarily dismissed without prejudice does not give rise to a statutory bar under § 315(b).

*F. Asserted Obviousness of Claim 4
over Sakamoto and Odaohhara*

Petitioner contends claim 4 of the '833 patent is unpatentable as obvious over the combination of Sakamoto and Odaohhara. Pet. 7, 36–39; *see also* Reply 11–21. Patent Owner disputes Petitioner's contentions. PO Resp. 16–27. We have reviewed the full record from trial, and we determine that Petitioner has shown by a preponderance of the evidence that claim 4 of the '833 patent is unpatentable as obvious over Sakamoto and Odaohhara.

1. Overview of Sakamoto (Ex. 1009)

Sakamoto is a Japanese Patent Application Disclosure, published on October 3, 2003. Ex. 1009, [43]. Based on the earliest possible priority date of the '833 patent (*see supra* Section I.C), we conclude that Sakamoto is prior art to the '833 patent under 35 U.S.C. § 102(b).

Sakamoto, like the '833 patent, relates to an adapter for converting power from a commercial power source to power for an electronic device such as a computer or cell phone, wherein the adapter can be switched to an “off” state in which the adapter does not consume power from the commercial power source. Ex. 1009, Abstract, ¶ 1. Sakamoto discloses an adapter for converting AC power to DC power, the conversion

App. 24

circuitry including transformer 21, rectifier circuit 22, and smoothing circuit 23. *Id.* at Abstract. According to Sakamoto, conventional AC adapters have the problem that even when the AC adapter is not being used to charge an electronic device, the adapter continues to draw power from the commercial power source because the primary winding of the transformer is still connected to the power source. *Id.* ¶ 3. In order to address the stated problem, Sakamoto discloses providing a switch connected to a circuit of the primary winding of the transformer and a switch on the electronic device side, so that when open, the transformer cannot draw power. *Id.* ¶¶ 4–7. Figures 1 and 2 of Sakamoto are reproduced below.

[FIG. 1]

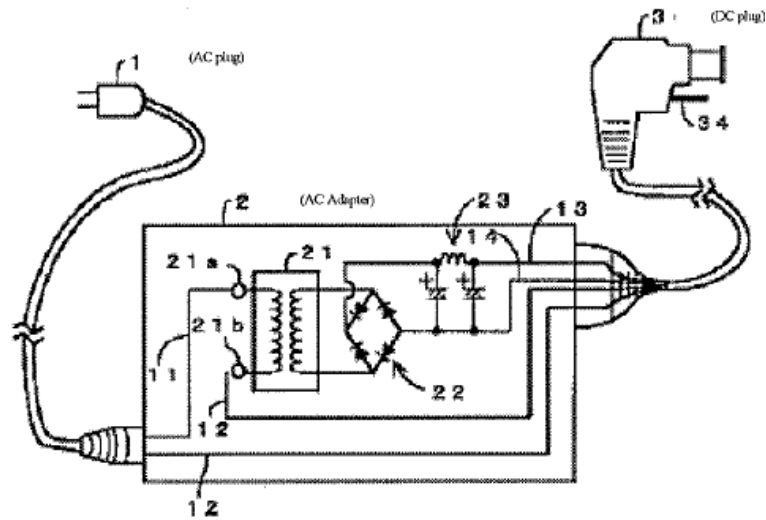

[FIG. 2]

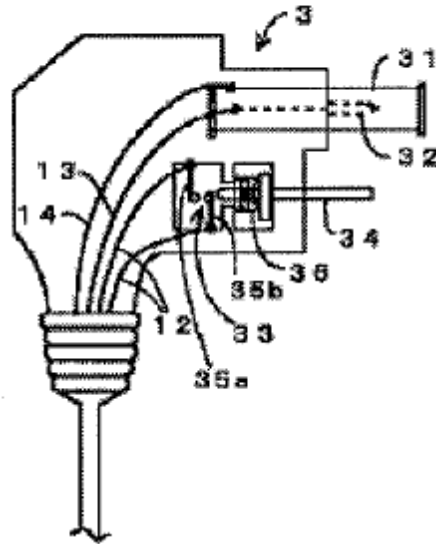

Ex. 1009, Figs. 1-2. Figure 1 depicts AC plug 1, AC adapter 2, and DC plug 3, wherein AC adapter 2 converts AC power from AC plug 1 (which receives power from a commercial power source) to DC power for supplying power to DC plug 3. *Id.* ¶ 9. Figure 1 further depicts circuitry in AC adapter 2, including transformer 21, rectifier 22, and smoothing circuit 23. *Id.* ¶ 10. Figure 2 depicts the interior of DC plug 3. *Id.* ¶ 12. Depicted in the figures, terminals 21a and 21b of the primary winding of transformer 21 are connected to the two terminals of AC plug 1 via wires 11 and 12, wherein wire 12 includes switch 33. *Id.* ¶ 11. When an electronic device is plugged into DC plug 3, pin 34 is depressed and causes electrically conductive tangent points 35a and 35b to contact each other, thereby closing the circuit so that current can be supplied to the

App. 26

primary winding of transformer 21 via wire 12. *Id.* ¶ 14. When no electronic device is plugged into DC plug 3, spring 36 pushes pin 34 outward so that tangent points 35a and 35b do not contact each other, thus opening the circuit so that no power from the commercial power source is supplied to the primary winding of transformer 21. *Id.* ¶ 15. Sakamoto discloses that, in this manner, “the consumption of energy from the commercial power source is completely eliminated and the wasteful consumption of power can be prevented.” *Id.*

2. Overview of Odaohhara (*Ex. 1010*)

Odaohhara is a U.S. Patent, issued on January 10, 2006. *Ex. 1010*, [45]. The application leading to the Odaohhara patent was published on December 19, 2002. *Id.* at [65]. Based on the earliest possible priority date of the '833 patent (*see supra* Section I.C), we conclude that Odaohhara is prior art to the '833 patent under 35 U.S.C. § 102(b).

Odaohhara relates to an AC adapter that converts AC power from a commercial power source to DC power, wherein the AC adapter is configured to reduce power loss. *Ex. 1010*, 4:16–26, 1:8–11. Odaohhara discloses that power loss is reduced by operating the AC adapter at a first switching frequency when the AC adapter is connected to the jack of the device being charged, and operates at a second switching frequency when the AC adapter is disconnected from the jack. *Id.* at 2:42–49. Figure 1 of Odaohhara is reproduced below.

FIG. 1

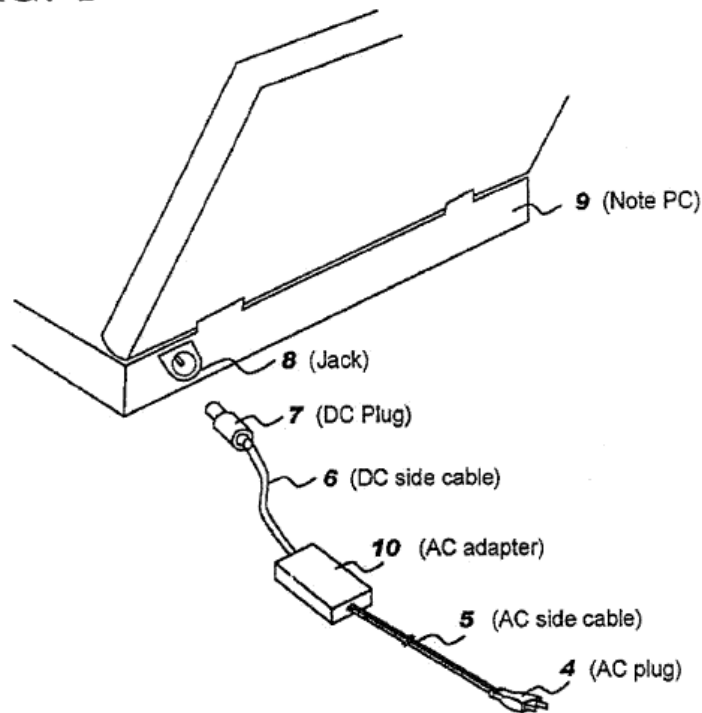

Ex. 1010, Fig. 1. Figure 1 depicts AC plug 4 for receiving commercial AC power, which is supplied through AC cable 5 to AC adaptor 10. *Id.* at 4:19–22. AC adaptor 10 converts the AC power to DC power, and the DC power is transmitted through DC side cable 6 to DC plug 7, where the power may be transmitted through jack 8 to note PC 9. *Id.* at 4:22–28. Odaohhara discloses including a mechanical switch in DC plug 7 such that when the switch is open, the AC adapter shifts to a low-power-loss mode, i.e., second switching frequency. *Id.* at 5:49–50, 6:10–16, 6:25–31.

3. *Discussion*

Claim 4 depends directly from independent claim 1. Petitioner identifies where each element of claim 1 is disclosed in Sakamoto in its analysis with respect to claim 1. Pet. 16–22, 36.

With respect to the preamble of claim 1, Petitioner relies on Sakamoto’s AC adapter 2 and DC barrel connector 3 for disclosure of a “power device for supplying power to a portable rechargeable electronic device.” Pet. 16. Patent Owner does not make any arguments regarding the preamble of claim 1. We are persuaded that Sakamoto’s AC adapter 2 and DC barrel connector 3 comprise a power device for supplying power as recited in the preamble because Sakamoto discloses these components provide power to an “electronic device such as a computer or a cellular telephone.” *See, e.g.*, Ex. 1009, 4 [Conventional Art]; Ex. 1009, 2; *see also id.* ¶ 9.

Petitioner argues AC adapter 2 integrated into one body with AC plug 1 satisfies the “first portion for receiving electrical input power” limitation of claim 1 because AC plug 1 connects to a power outlet. Pet. 16–17 (citing Ex. 1009 ¶¶ 9, 22). Petitioner argues further that the input power received by AC plug 1 has an input voltage, as required by claim 1, because Sakamoto discloses the input is an “alternating current,” which inherently has input voltage. *Id.* at 17 (citing Ex. 1009 ¶ 9; Ex. 1019 ¶¶ 58–59). Patent Owner does not make any arguments regarding this claim limitation. We are persuaded that Sakamoto’s AC plug 1 integrated with

AC adapter 2 receives electrical input power because it receives an input alternating electrical current from a power outlet. Ex. 1009 ¶¶ 9, 22.

Petitioner argues Sakamoto's DC plug 3 satisfies the "second portion for delivering electrical output power" limitation of claim 1 because Sakamoto discloses that DC plug 3 supplies DC power to an electronic device. Pet. 17 (citing Ex. 1009, Fig. 1, ¶ 9; Ex. 1019 ¶ 60). Patent Owner does not make any arguments regarding this claim limitation. We are persuaded by Petitioner's arguments because Sakamoto discloses direct electrical current supplied by DC plug 3 provides electrical power to an electronic device. *See* Ex. 1019 ¶ 60 (citing Ex. 1009 ¶ 9 ("[I]n the DC plug 3, an OA device such as a computer is connected and a direct current power is supplied to the OA device.")).

With respect to the limitation of claim 1 requiring "a connector located on the second portion and removably connectable with the electronic device," Petitioner relies on cylindrical terminal 31 included in DC plug 3, wherein "terminal (31) inserts into a terminal of a computer to removably connect with the computer." Pet. 18 (citing Ex. 1009 ¶¶ 14, 9; Ex. 1019 ¶ 61). Patent Owner does not make any arguments regarding this claim limitation. We are persuaded by Petitioner's arguments because Sakamoto discloses, for example, that terminal (31) connects with (e.g., is plugged into) and disconnects (e.g., is removed from) from [sic] a power source terminal of an electronic device such as a computer. Ex. 1009 ¶ 14.

As to the limitation “a switch assembly having a member movable to and between first and second positions corresponding to respective ‘on’ and ‘off’ states of the power device, wherein the power device receives the input power in the ‘on’ state, and the power device draws no input power in the ‘off’ state,” as recited in claim 1, Petitioner relies on the combination of Sakamoto’s operation pin 34, spring 36, and tangent points 35a and 35b. Pet. 18–22 (citing Ex. 1009 ¶ 13). Petitioner argues operation pin 34 is a “member movable to and between first and second positions.” *Id.* at 19 (citing Ex. 1009 ¶¶ 13, 14; Ex. 1019 ¶ 64). When pin 34 is in a first position, i.e., depressed, contact points 35a and 35b contact each other, thus closing the circuit so that power is delivered (i.e., the power device is in an “on” state). *Id.* (citing Ex. 1009 ¶ 14). When pin 34 is in a second position, i.e., not depressed, contact points 35a and 35b do not contact each other, thus forming an open circuit in which power is not drawn (i.e., the power device is in an “off” state). *Id.* (citing Ex. 1009 ¶ 15). Patent Owner does not make any arguments regarding this claim limitation. We are persuaded that the combination of Sakamoto’s operation pin 34, spring 36, and tangent points 35a and 35b satisfies the “switch assembly” limitation because Sakamoto discloses, for example, moving pin 34 from a first position in which the circuit is closed (contact points 35a and 35b contact each other) and power is delivered, and second position in which the circuit is open (contact points 35a and 35b do not contact each other) and power is not delivered. Ex. 1009 ¶¶ 14–15.

App. 31

Claim 4 further recites “[t]he power device of claim 1 wherein the switch assembly member is a sheath longitudinally movable to and between the first and second positions.” Petitioner acknowledges Sakamoto does not disclose a sheath, but argues it would have been obvious, in view of Odaohhara, to modify the moveable member in Sakamoto to be a sheath. Pet. 36–39. Petitioner argues, in particular, that Sakamoto teaches operational pin 34 can touch another body and become deformed. *Id.* at 38 (citing Ex. 1009 ¶ 20). To address this, Sakamoto discloses an embodiment in which cylindrical housing 92 is included over pin 34, depicted in Figures 10a and 10b, reproduced below.

[FIG. 10]

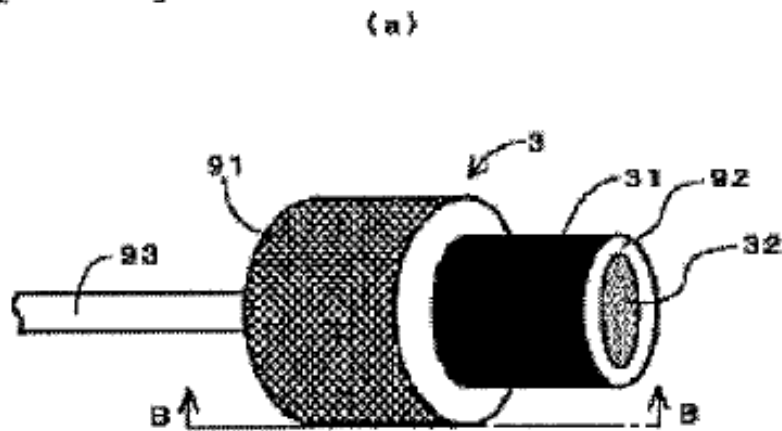

App. 32

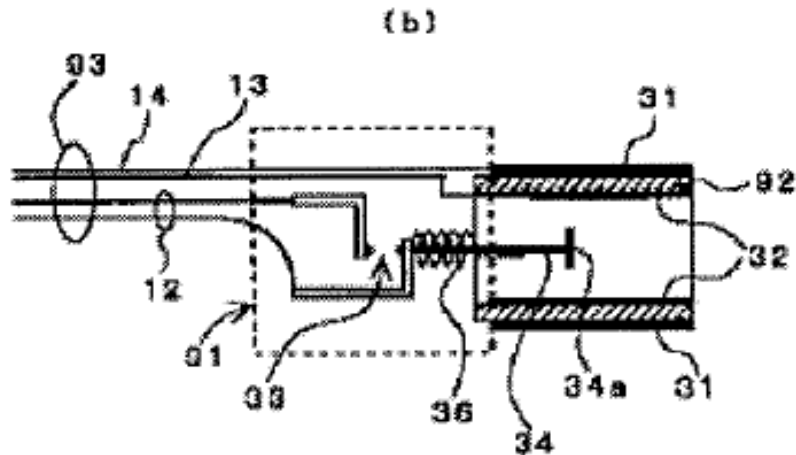

Ex. 1009, Figs. 10a, 10b. Depicted in Figures 10a and 10b, pin 34 still operates as a switch within housing 92, but housing 92 is not moveable. *Id.* ¶ 20. Sakamoto discloses that “since the operation pin 34 exists inside the second cylindrical housing 92, there is no risk of touching another body and deforming,” and that as a result, “the risk of malfunction is small, and a compact DC plug can be provided.” *Id.*

Odaohhara provides a switch assembly in which a longitudinally moveable sheath, i.e., moveable section 52, acts as a switch to switch a power device between being an open and a closed circuit. Ex. 1010, 5:56–59, 6:3–16, Figs. 3A, 3B. Odaohhara’s switch assembly is depicted in Figures 3a and 3b, reproduced below.

3A

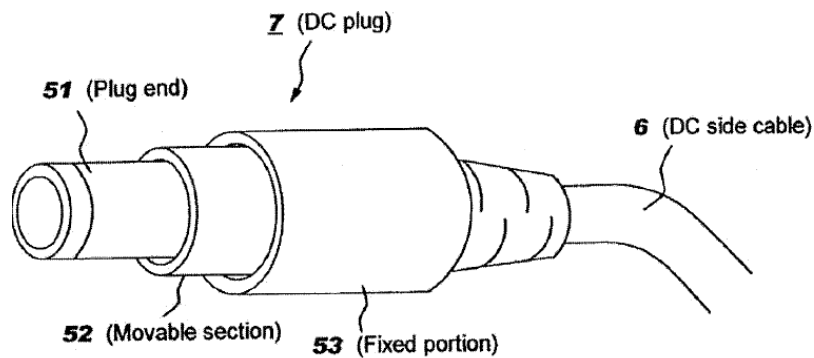

3B

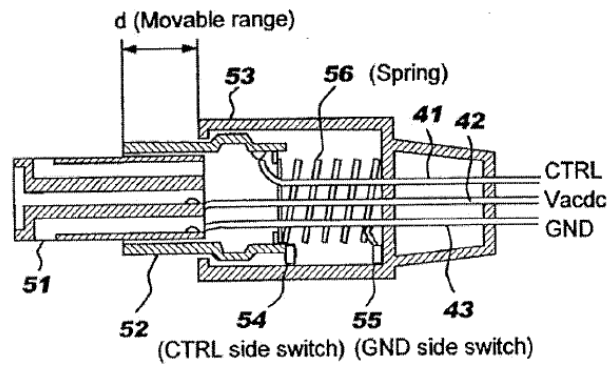

Ex. 1010, Figs. 3a, 3b. Moveable section 52 in Odaohhara operates on the same principle as pin 34 in Sakamoto. A spring is used in Odaohhara to bias moveable section 52 to an extended position (*id.* at 6:3-16), just as a spring is used in Sakamoto to bias pin 34 to an extended position (Ex. 1009 ¶¶ 14-15). In Odaohhara, when an electronic device is connected to jack 8, moveable section 52 contracts [sic] a spring, and CTRL slide switch 54 contacts GND side switch 55 to close

App. 34

the circuit. Ex. 1010, 6:3–16. Similarly, when an electronic device is connected to terminal 31 in Sakamoto, pin 34 contracts the spring and brings tangent points 35a and 35b into contact with each other to close the circuit. Ex. 1009 ¶¶ 14–15. Petitioner argues Odaohhara’s moveable housing 52 provides a more sturdy structure than Sakamoto’s pin 34, and it would therefore have been obvious to a skilled artisan to modify Sakamoto’s pin 34 to include a sheath. Pet. 38.

Petitioner also argues that a person of ordinary skill in the art would have recognized that pin 34 in Sakamoto is not symmetrical around the point at which an electronic device is connected to DC plug 3, namely terminal 31. *Id.* According to Petitioner, a skilled artisan would have recognized the benefit of providing the moveable sheath taught in Odaohhara to allow pressing at any position about terminal 31 to close Sakamoto’s switch assembly. *Id.* Such a modification, Petitioner argues, would have been a combination of known elements in a predictable way to produce predictable results. *Id.* at 39 (citing *KSR*, 550 U.S. at 417); *see also* Ex. 1019 ¶¶ 139–140 (testimony of Dr. Horenstein).

Petitioner has provided sufficient articulated reasoning with rational underpinning to support the legal conclusion of obviousness as to claim 4. *See KSR*, 550 U.S. at 418.

With respect to claim 4, Patent Owner asserts Petitioner is “re-hashing” an unsuccessful argument Petitioner made during reexamination of the ’833 patent.

PO Resp. 16–21. Even if it were a “re-hash,” and we do not agree that it is, Petitioner is not estopped under 35 U.S.C. § 315(e) from arguing the combination of Sakamoto and Odaohhara. *See supra* Section II.D. In any event, we disagree that Petitioner is “re-hashing” an argument made in the ’833 reexamination. In the reexamination, Bhogal was asserted as the primary reference, rather than Sakamoto, but like here, Odaohhara was relied on for disclosure of a “sheath longitudinally movable to and between the first and second positions.” *See Ex. 1004, 24.*

Patent Owner argues that during reexamination, Petitioner made the “same” argument regarding obviousness of using a sheath, as disclosed in Odaohhara, instead of a pin. PO Resp. 16–21. Specifically, Patent Owner argues Bhogal’s control contact (28) is substantially similar to Sakamoto’s pin (34), and therefore, Petitioner’s argument in this proceeding is the “same” as that made during reexamination. *Id.* at 19. We disagree with Patent Owner’s assessment. Contrary to Patent Owner’s assertion, Petitioner successfully argued claim 4 is unpatentable as obvious over Bhogal and Odaohhara. Ex. 1003, 10. The Decision on Appeal left untouched the Examiner’s determination it would have been obvious to modify Bhogal to include Odaohhara’s moveable housing. Reply 4; *see generally* Ex. 1004. The issue in the Decision on Appeal was not whether it would have been obvious to use a moveable sheath instead of a pin. Rather, the issue was whether the combination would have resulted in a power device that draws no input power when in the “off” state. Ex.

1004, 25–26. The Decision on Appeal states “[t]he dispositive issue” with regard to the “switch assembly” limitation is “whether the Examiner has established that Bhogal’s power supply draws no input power when in the ‘off’ state,” wherein the phrase “draws no input power” was construed to mean power on the order of microwatts. *Id.* at 25.

In the reexamination proceeding, the parties agreed Bhogal depicts achieving the “off” state by opening the circuit on the secondary side of a transformer. Ex. 1004, 26. Patent Owner argued that in this configuration, because the transformer is still connected to, and forms a circuit with, a power source, the transformer necessarily draws phantom input power greater than microwatts. *Id.* The Board found the evidence of record indicated a circuit opened on the secondary side of a transformer winding will continue to draw phantom power that is greater than microwatts. *Id.* at 29. In contrast, Sakamoto discloses power being cut on the primary side of the transformer, such that the transformer is not connected to the power source. Reply 5 (citing Ex. 1009, Fig. 1). Sakamoto further discloses power consumption is “completely eliminated.” *Id.* (citing Ex. 1009 ¶ 15). Accordingly, we disagree with Patent Owner’s argument that Petitioner is re-hashing a previously made argument.

Patent Owner also argues Sakamoto teaches away from using Odaohhara’s sheath structure. PO Resp. 21–24. Patent Owner bases its argument on Sakamoto’s teaching of a cylindrical housing to prevent deformation of pin (34). *Id.* at 21. According to Patent

Owner, because Sakamoto, “by itself, solves the problem [Petitioner] asserts the combination with Odaohara would solve,” the combination is unnecessary and Sakamoto “itself teaches away from the combination and thus excludes any motivation to combine.” *Id.* at 23–24. We disagree that Sakamoto’s teaching a solution to a problem teaches away from using other solutions to solve the same problem. “A reference may be said to teach away when a person of ordinary skill, upon reading the reference, would be discouraged from following the path set out in the reference, or would be led in a direction divergent from the path that was taken by the applicant.” *In re Gurley*, 27 F.3d 551, 553 (Fed. Cir. 1994). “A reference does not teach away . . . if it merely expresses a general preference for an alternative invention[.]” *See DePuy Spine, Inc. v. Medtronic Sofamor Danek, Inc.*, 567 F.3d 1314, 1327 (Fed. Cir. 2009). Sakamoto does not expressly discourage using a moveable sheath to address the risk of a deformed pin. Ex. 1009 ¶ 20. In fact, Sakamoto does not discourage any particular method for avoiding pin deformation. *Id.* Rather, Sakamoto describes a non-limiting embodiment in which a cylindrical housing is used, a benefit of which is eliminating “risk of [pin (34)] touching another body and deforming. Because of this, the risk of malfunction is small, and a compact DC plug can be provided.” *Id.* Accordingly, Sakamoto teaches that it is desirable to avoid pin deformation, but Sakamoto does not discourage any particular method of accomplishing this goal. Sakamoto’s disclosure of one way to achieve this goal does not amount to teaching away from using other methods.

Patent Owner also argues Sakamoto’s disclosure is non-enabling. PO Resp. 24–25. Prior art patents and publications are presumed to be enabled. *In re Antor Media Corp.*, 689 F.3d 1282, 1287–89 (Fed. Cir. 2012); *see also Microsoft Corp. v. Parallel Networks Licensing LLC*, 715 F. Appx. 1013, 1021 (Fed. Cir. 2017) (“And, if necessary, the Board should address Parallel’s contention that this disclosure in SWEB is not enabled—applying our law that generally accords presumption of enablement to printed-publication and patent prior art. *In re Antor Media Corp.*, 689 F.3d 1282, 1289, 1292 (Fed. Cir. 2012) (printed publications); *Amgen Inc. v. Hoechst Marion Roussel, Inc.*, 314 F.3d 1313, 1355 (Fed. Cir. 2003) (patents).”). Accordingly, we presume Sakamoto is enabled—a presumption that Patent Owner may overcome. *See id.*

The presumption of enablement has not been overcome. According to Patent Owner, the circuit disclosed by Sakamoto, in which wires (12) are routed from a power source directly to a switch assembly on a DC connector, and then to equipment to which power is supplied, “could not be implemented because it violated electromagnetic interference and safety standards.” PO Resp. 24–25 (citing Ex. 2021 ¶ 23). The only support Patent Owner provides for its assertion is the unsupported, conclusory testimony of Dr. Tobias, who states “[a]ny PHOSITA would immediately recognize that this circuit violates a number of product electromagnetic interference and safety standards as will be described.” Ex. 2021 ¶ 23. Dr. Tobias neither identifies the purported safety standards nor cites to any

documents that set forth the alleged standards, much less explains why Sakamoto's circuitry violates any standards. *Id.*; *see also* Reply 13–14. “Expert testimony that does not disclose the underlying facts or data on which the opinion is based is entitled to little or no weight.” 37 C.F.R. § 42.65. Therefore, we accord little weight to Dr. Tobias's unsupported testimony. Also, Petitioner points out that even if a regulatory standard was violated, and it has not been shown there is such a violation, compliance with a regulatory standard is not a requirement of enablement. Reply 14 (citing *Scott v. Finney*, 34 F.3d 1058, 1063 (Fed. Cir. 1994)).

Dr. Tobias also testifies, without providing underlying support, that significant changes would need to be made to isolate DC components from AC components, and that to use Sakamoto's DC circuitry to control the AC circuit would require additional circuits that would require “a completely different design.” Ex. 2021 ¶ 23. These assertions also lack support, and we accord them little weight.

We are persuaded Sakamoto is enabled with regard to the features at issue. Sakamoto discloses circuit and structural diagrams in Figures 1 and 2, with accompanying written disclosure. Ex. 1009, Figs. 1–2, ¶¶ 8–15. Dr. Horenstein opines that a person of ordinary skill in the art would have been able to make and use the device taught in Sakamoto without undue experimentation based on the teachings provided in Sakamoto and Odaohhara. Reply 17 (citing Ex. 1033 ¶¶ 27–42). We credit Dr. Horenstein's testimony based on the circuit and structural diagrams and

accompanying disclosure in the prior art which reflect the level of ordinary skill in the art, and which provide detail on the components and operation of the device at issue. *Okajima*, 261 F.3d at 1355.

For the foregoing reasons, we disagree with Patent Owner that Sakamoto is not enabled.

Even if the features in Sakamoto identified by Patent Owner were not enabled, “[u]nder § 103 . . . a reference need not be enabled; it qualifies as a prior art [reference], regardless, for whatever is disclosed therein . . . enablement of the prior art is not a requirement to prove invalidity under § 103.” *Amgen*, 314 F.3d at 1357; *see also Beckman Instruments, Inc. v. LKB Produkter AB*, 892 F.2d 1547, 1551 (Fed. Cir. 1989) (“Even if a reference discloses an inoperative device, it is prior art for all that it teaches.”). As we discussed above, Petitioner has shown the combination of Sakamoto and Odaohhara teaches the limitations recited in claim 4, and claim 1 from which claim 4 depends. Safety features, as alleged by Patent Owner, are not a requirement of claim 4. Reply 17. Accordingly, failure to comply with such standards does not constitute lack of enablement with regard to the features recited in claim 4.

Patent Owner also argues the “real world implementation” of Sakamoto would fail to “draw[] no input power in the ‘off’ state,” as recited in claim 1, from which claim 4 depends. PO Resp. 25 (emphasis omitted). Patent Owner’s assertion contradicts the express disclosure of Sakamoto, which states that in the

asserted “off” state “the consumption of energy from the commercial power source is *completely eliminated*.” Reply 19 (quoting Ex. 1009 ¶ 15) (emphasis added). In particular, Sakamoto discloses disconnecting wire 12 (in order to open the circuit) at the primary winding of transformer 21 in order to completely eliminate power consumption. PO Resp. 25–26 (citing Ex. 1009 ¶ 15). Patent Owner acknowledges that the goal of this arrangement in Sakamoto is to completely eliminate power consumption. *Id.* However, Patent Owner nonetheless argues that Sakamoto’s goal is an “impractical theoretical embodiment,” and that “breaking the AC supply to the primary transformer does not remove the AC power from other essential elements of real power supplies.” *Id.* In support of its argument, Patent Owner asserts in a real world embodiment “there are other elements” upstream of the primary transformer winding necessary for preventing interference and for surge protection that draw power from the power supply. *Id.* at 26. Patent Owner relies on the unsupported testimony of Dr. Tobias. *Id.* (citing Ex. 2021 ¶¶ 24–26). Dr. Tobias does not cite any underlying evidence to show the alleged “other elements” would have been necessary in Sakamoto. Ex. 2021 ¶¶ 24–26. Therefore, his testimony is accorded little weight. Also, as we discussed above, Sakamoto is presumed enabled, and is considered for everything it teaches. In addition, there is no disclosure in Sakamoto of the “other elements” described by Dr. Tobias, and no express disclosure that such would be necessary. Petitioner argues that the “other elements” described by Dr. Tobias, if they were desirable to include, could be added downstream,

rather than upstream, of the primary winding of transformer 21, so that they would draw no power in an “off” state, and that it would be desirable to do so in light of Sakamoto’s goal of eliminating power consumption in an “off” state. Reply 20. Sakamoto’s goal of drawing no power in an “off” state is expressly stated: “an AC adaptor that resolves the problem of the above stated conventional art [referring to AC flowing in the primary transformer], and is configured so that AC power is not consumed from the commercial power source.” Reply 21 (quoting Ex. 1009 ¶ 4).

Upon review of the record in this proceeding, we determine that Petitioner has demonstrated by a preponderance of the evidence that claim 4 of the ’833 patent is unpatentable under § 103 as obvious over the combination of Sakamoto and Odaohhara.

*G. Asserted Obviousness of claims
11, 12, 17, 18, 20, and 21 over Noguchi and
Huang, and over Noguchi, Huang, and Suzuki*

Petitioner contends claims 11, 12, 17, 18, 20, and 21 of the ’833 patent are unpatentable as obvious over the combination of Noguchi, Huang, and Suzuki. Pet. 7, 39–60. Patent Owner disputes Petitioner’s contention. PO Resp. 27–31. In our Institution Decision, we instituted based on the combination of Noguchi and Huang, with or without Suzuki. Inst. Dec. 21–29, 33. We have reviewed the full record from trial, and we determine that Petitioner has shown by a preponderance of the evidence that claims 11, 12, 17, 20, and 21 of the

'833 patent are unpatentable as obvious over the combination of Noguchi and Huang, and claim 18 is unpatentable as obvious over the combination of Noguchi, Huang, and Suzuki.

1. Overview of Noguchi (Ex. 1011)

Noguchi is a Japanese Patent Application Disclosure, published on July 12, 2002. Ex. 1011, [43]. Based on the earliest possible priority date of the '833 patent (*see supra* Section I.C), we conclude that Noguchi is prior art to the '833 patent under 35 U.S.C. § 102(b).

Noguchi relates to a battery charger including converter 20 for converting AC current supplied by an AC power source to DC power for charging a battery, wherein the battery charger “automatically prevents unnecessary standby power consumption caused by a converter built in to the charger.” Ex. 1011, Abstract. Noguchi discloses preventing such power consumption by providing switch 10 on the input side of converter 20 that turns the converter off when the battery is removed from the battery charger. *Id.* Figure 1 of Noguchi, reproduced below, depicts the circuitry of the battery charger.

Fig. 1

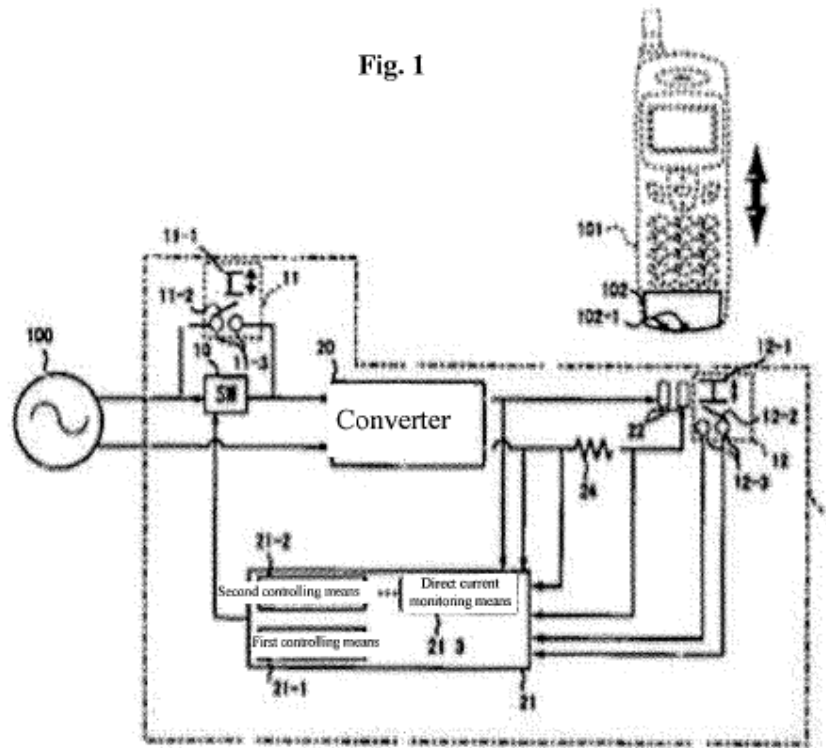

Ex. 1011, Fig. 1. Depicted in Figure 1, AC power supply 100 supplies AC power to converter 20, which converts the AC power into DC power. *Id.* ¶ 13. The DC power is supplied to rechargeable battery 102. *Id.* Switch 10 is interposed between AC power supply 100 and the input side of converter 20, and when open (i.e., off), cuts off the alternating current from AC power supply 100. *Id.* ¶ 16. Control unit 21, depicted in Figure 1, opens switch 10 when either rechargeable battery 102 is detached from the charger or when battery 102 is fully charged. *Id.* ¶ 26. Noguchi further discloses bypass switch 11, which is closed, i.e., turned on, when bypass switch button 11-1 is pressed. *Id.* ¶ 34. Bypass switch

11, when closed, bypasses switch 10 and causes AC power to be delivered to converter 20, and therefore rechargeable battery 102, as well as control unit 21, when switch 10 is open. *Id.* ¶¶ 34–35.

2. *Overview of Huang (Ex. 1013)*

Huang is a U.S. Patent Publication, published on August 22, 2002. Ex. 1013, [43]. Based on the earliest possible priority date of the '833 patent (*see supra* Section I.C), we conclude that Huang is prior art to the '833 patent under 35 U.S.C. § 102(b).

Huang generally discloses a battery charging base for a cellular telephone. Ex. 1013 ¶ 3. In pertinent part, Huang's battery charger comprises base 11, AC adapter 21 connected to base 11, top receptacle 15, and cellular telephone connector 13 disposed in receptacle 15. *Id.* Connector 13 is adapted to receive a particular model of cellular telephone. AC adapter 21 converts AC power supplied from an outlet to DC power for charging the battery of the cellular telephone. *Id.*

3. *Overview of Suzuki (Ex. 1012)*

Suzuki is a U.S. Patent, issued on December 3, 2002. Ex. 1012, [45]. The PCT application leading to Suzuki was published on March 16, 2000. *Id.* at [87]. Based on the earliest possible priority date of the '833 patent (*see supra* Section I.C), we conclude that Suzuki is prior art to the '833 patent under 35 U.S.C. § 102(b).

Suzuki generally relates to a power saving circuit to save standby power of electronic devices. Ex. 1012, Abstract [57]. Figure 1 of Suzuki is reproduced below:

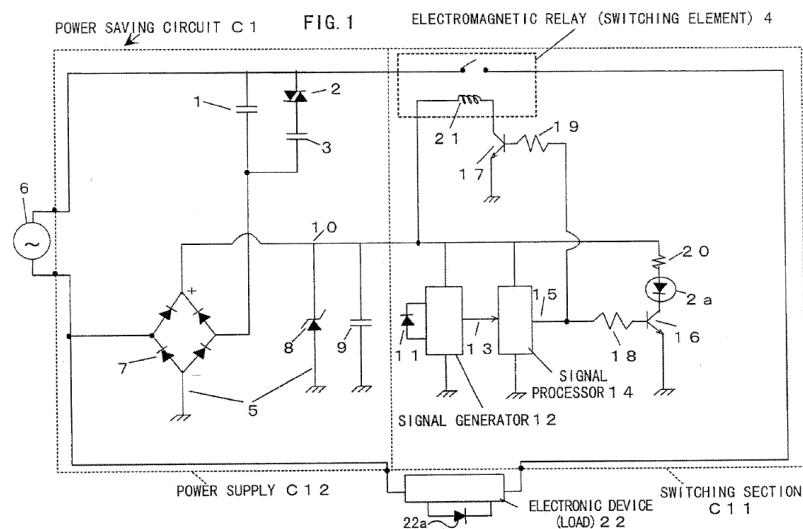

Ex. 1012, Figure 1. Figure 1 depicts power saving circuit C1, which Suzuki discloses “is an adapter unit connected between an AC power supply 6 and an electronic device 22 as a load that receives the supply during operation.” *Id.* at 2:61–63. Circuit C1 comprises switching section C11 that performs switching for selection between standby mode and operate mode, and power supply section C12 that supplies power to switching section C11. *Id.* at 2:64–67, Fig. 1. Power supply section C12 includes, in pertinent part, phototriac 2, which when turned on, allows alternating current to flow from AC power supply 6, which increases current output capability of DC power supply 10. *Id.* at 3:14, 3:61–67. The increased current output supplies the current necessary to cause relay 4 in switching

App. 47

section C11 to turn on, which in turn causes AC voltage from AC power supply 6 to be supplied to electronic device 22, placing electronic device 22 in a standby state. *Id.* at 4:2–7. When electronic device 22 receives an ON command by infrared signal, it shifts from standby state to operating state. *Id.* at 4:9–10. Suzuki discloses that when power saving circuit C1 receives an OFF command, relay 4 turns off, phototriac 2 turns off, and circuit C1 enters standby mode. *Id.* at 4:11–16. Claim 1 of Suzuki recites “a first switching element (4),” wherein the number “(4)” refers to relay 4, and “a second switching element (2),” wherein the number “(2)” refers to phototriac 2. *Id.* at 19:53–54, 57–58. Claim 2 of Suzuki, from which claim 1 depends, recites that “one of said first and second switching elements (2, 4) comprises a latching-type electromagnetic relay, a nonlatching-type electromagnetic relay, a triac, or a photo-coupler.” *Id.* at 20:15–19.

4. Discussion—Claim 11

Petitioner asserts Noguchi teaches the limitations of claim 11 except for the “connector located on the second portion and removably connectable with the electronic device” limitation, which Petitioner argues is taught by Huang. Pet. 39–51. Petitioner also argues that if we determine the claimed “switch assembly” must include a hard switch, it would have been obvious to modify the switch in Noguchi to be an electromagnetic switching element such as the latching relay taught in Suzuki. *Id.* at 51–54.

With respect to the preamble, Petitioner relies on Noguchi's charger 1 as teaching a power device. Pet. 39 (citing Ex. 1011 ¶¶ 2, 11, 12, 15; Ex. 1019 ¶ 159). Patent Owner does not make any arguments regarding the preamble of claim 11. We are persuaded that Noguchi's charger 1 teaches "[a] power device for supplying power to a portable rechargeable electronic device," as recited in the preamble of claim 11, because Noguchi discloses charger 1 charges mobile electronic devices such as cellular telephone 101, which includes rechargeable battery 102. Ex. 1011 ¶¶ 2, 11, 12, 15; Ex. 1019 ¶ 159.

With respect to the limitation directed to "a first portion for receiving electrical input power from a source, the input having an input voltage," Petitioner relies on plug 30 in Noguchi. Pet. 39–40 (citing Ex. 1011 ¶ 12, Figs. 2, 3; Ex. 1019 ¶ 160). Patent Owner does not make any arguments regarding this claim limitation. We are persuaded that Noguchi's plug 30 teaches this limitation because Noguchi discloses plug 30 receives alternating voltage from AC power supply 100. Ex. 1011 ¶ 12, Figs. 2, 3; Ex. 1019 ¶ 160.

With respect to the limitation directed to "a second portion for delivering electrical output power to the electronic device, the output power having an output voltage," Petitioner relies on main body case 1-1 in Noguchi. Pet. 40 (citing Ex. 1011 ¶¶ 12, 13; Ex. 1019 ¶ 161). Patent Owner does not make any arguments regarding this claim limitation. We are persuaded that Noguchi's main body case 1-1 teaches this limitation because Noguchi discloses case 1-1 delivers electrical

output power having an output voltage to an electronic device, i.e., case 1-1 delivers direct voltage to rechargeable battery 102 in cellular phone 101. Ex. 1011 ¶¶ 12, 13; Ex. 1019 ¶ 161.

With respect to claim 11's requirement that the power device include "circuitry for converting the input power voltage to the output power voltage," Petitioner argues Noguchi's converter 20 satisfies this requirement because it is "a common AC/DC converter." Pet. 40 (quoting Ex. 1011 ¶ 14). As to claim 11's further requirement of "circuitry . . . for determining an 'off' state of the circuitry," Petitioner argues control unit 21 of Noguchi determines when the state of switch 10 should be turned to "off." *Id.* at 40–41. In particular, Petitioner relies on Noguchi's disclosure that control unit 21 determines whether a condition for turning off switch 10 is present, namely whether "rechargeable battery 102 (cellular telephone 101) is detached from the charger 1 (first condition)" and whether "rechargeable battery 102 has reached a fully charged state (second condition)." *Id.* (citing Ex. 1011 ¶ 26; Ex. 1019 ¶¶ 162–163). Patent Owner does not dispute that Noguchi teaches the claimed circuitry. With respect to claim construction, Patent Owner argues we are bound by a Federal Circuit decision to construe the term "converting" a voltage "as being narrower than altering a signal and a capacitive filter is not a converter," (PO Resp. 1–2) but Patent Owner neither makes any specific arguments regarding claim 11, nor argues that Noguchi's converter 20 is a capacitive filter or otherwise fails to fall within the scope of claim 11 (*see*

generally id. at 27–31). As we discussed above with regard to claim construction, an AC to DC converter falls within the scope of the term “converting the input power voltage to the output power voltage.” *See supra* Section II.B.1. Because Noguchi discloses converter 20 is an AC to DC converter, and discloses circuitry that determines whether a condition for turning off switch 10 is present, we are persuaded Noguchi teaches the “circuitry” limitation. Ex. 1011 ¶ 14.

With respect to “a switch assembly having powered terminals, the switch assembly responsive to movement or at least a movable portion thereof to electrically connect the terminals to provide an output signal to activate the circuitry to the ‘on’ state,” Petitioner argues Noguchi discloses two alternative switch assemblies that satisfy this claim limitation. Pet. 45–51. The two switch assemblies are referred to herein as Switch 11 and Switch 12.¹¹ *Id.* at 45. Patent Owner does not make any arguments regarding this claim limitation.

Switch 11 includes the combination of bypass switch button 11-1, by-pass switch segment 11-2, bypass switch terminal/contact point 11-3, and “return spring and the like.” *Id.* (citing Ex. 1011 ¶¶ 18, 20, Fig.

¹¹ Although Petitioner refers to the second assembly as “Switch Assembly 11B,” (*see id.*) we refer to it as Switch 12 because it comprises secondary battery detection switch button 12-1, secondary battery detection switch segment 12-2, and secondary battery detection switch terminal/contact point 12-3, which Noguchi refers to collectively as secondary battery detection switch 12. Ex. 1011 ¶ 20.

1; Ex. 1019 ¶ 175). Petitioner argues the leftmost and rightmost terminals of switch terminal contact point 11-3 are “powered terminals” because they are electrically connected with the first line of AC power supply 100 when the power supply is plugged in. *Id.* at 45–46 (citing Ex. 1011 ¶ 14). With respect to the rightmost terminal, Petitioner argues the electrical connection is inherent or implicit because converter 20 necessarily connects the rightmost terminal with AC power supply 100. *Id.* at 46. Petitioner further argues that to the extent we find the connection is not inherent or implicit, it would have been obvious for the rightmost terminal to be a “powered terminal” in order “to efficiently allow the AC power supply 100 circuit to close when bypass switch 11 closes.” *Id.* (citing Ex. 1019 ¶¶ 177–181). We are persuaded the rightmost terminal necessarily connects with AC power supply 100 when Switch 11 is closed, otherwise electrical power could not be transmitted through Switch 11. Ex. 1019 ¶ 178. Having reviewed the evidence of record, we are persuaded Switch 11 has powered terminals because Noguchi discloses terminals electrically connected with AC power supply 100 which provides power.

With regard to the limitation “responsive to movement or at least a movable portion thereof to electrically connect the terminals to provide an output signal to activate the circuitry to the ‘on’ state” (“the responsive to movement limitation”), Petitioner argues Switch 11 is responsive because when a user presses button 11-1, terminals 11-3 are connected, and Switch 11 is turned on. Pet. 47. According to Petitioner, when

Switch 11 is open, charger 1 of cellular phone 101 draws no power, but when Switch 11 is closed (i.e., turned on), an “output signal” in the form of electricity is transmitted from Switch 11 to converter 20 to initiate operation of converter 20 and control unit 21 that moves the switch to the “on state.” *Id.* at 47–48. Because Switch 11 is responsive to the movement of pressing a button, and an output signal in the form of electricity is transmitted to initiate moving the switch to an on state, we are persuaded Noguchi’s Switch 11 discloses the “responsive to movement” claim limitation.

Switch 12 includes the combination of secondary battery detection switch button 12-1, secondary battery detection switch segment 12-2, and secondary battery detection switch terminal/contact point 12-3. *Id.* at 45 (citing Ex. 1011 ¶ 20, Fig. 1; Ex. 1019 ¶ 176). With respect to Switch 12, Petitioner argues Noguchi discloses powered terminals, namely battery detection terminal/contact point 12-3. *Id.* at 48. We are persuaded battery detection terminal/contact point 12-3 are powered terminals because Noguchi discloses when AC power supply 100 is plugged in and secondary battery detection switch segment 12-2 contacts both terminals of switch terminal/contact point 12-3, electricity (i.e., power) is transmitted. *Id.* (citing Ex. 1011 ¶ 22; Ex. 1019 ¶¶ 185–186).

We are also persuaded Petitioner has shown Switch 12 teaches the “responsive to movement” limitation because, as pointed out by Petitioner, Noguchi discloses battery detection switch button 12-1 that is

pushed down (e.g., is moveable) by the weight of cellular telephone 101 to turn on Switch 12. *Id.* at 49 (citing Ex. 1011 ¶ 22).

With regard to the limitation “wherein the circuitry automatically turns the circuitry to the ‘off’ state, the circuitry drawing no power when in the ‘off’ state,” Petitioner argues Noguchi discloses the claimed circuitry, namely the combination of switch 10, converter 20, and control unit 21. Petitioner relies on Noguchi’s disclosure that when control unit 21 detects battery 102 is detached from charger 1 or is fully charged, switch 10 automatically turns off. Pet. 51 (citing Ex. 1011 ¶¶ 26–29). According to Petitioner, the circuitry draws no power when in the “off” state because Noguchi discloses that “when the switch 10 is turned off, the alternating current for the converter 20 is cut off.” *Id.* (citing Ex. 1011 ¶ 33).

As we discussed above (*see supra* Section II.B.2), the Decision on Appeal noted that the ’833 patent specification discloses that when power is cut, “the power draw is zero or negligible (i.e., measured in microwatts).” Ex. 1004, 26 (citing Ex. 1001 6:49–50). The Board determined that in order for the prior art at issue to satisfy the claim limitation, it had to disclose drawing power in the “off” state that “is only on the order of microwatts.” *Id.* (citing *Edwards Lifesciences LLC v. Cook Inc.*, 582 F.3d 1322, 1334 (Fed. Cir. 2009) (noting that the term “i.e.” in a patent specification signals an intent to define the term to which it refers)). The ’833 patent explains that “[i]n order to be a true ‘zero-energy’ device, the power input (i.e., AC input) to

the power device must be cut,” and that “the point in the power device circuitry where the circuit is broke is important.” Ex. 1001, 2:53–66. The ’833 patent explains that the portion of a power device most directly responsible for power draw or phantom load in the “off” state are the switcher IC chip, transformer, and components downstream therefrom because they continue to draw power from the AC input power source even when the electronic device is disconnected from the power device. *Id.* at 8:20–23. According to the ’833 patent, phantom load in the “off” state is virtually eliminated, therefore, by placing the switch that opens the circuit (such as at terminals 50a and 50b depicted in Figure 8) upstream from the transformer. *Id.* at 8:23–31. Like the ’833 patent, Noguchi discloses placing switch 10 upstream from converter circuitry, so that when the switch is open, the alternating current supplied by AC power supply 100 is cut off. Ex. 1011 ¶ 16; *see also id.* at Fig. 1 (depicting switch 10 interposed between AC power supply 100 and converter 20). Because Noguchi’s switch 10 is upstream from power conversion circuitry, we are persuaded Noguchi’s “circuitry” draws no power in the “off” state.

Petitioner acknowledges Noguchi does not teach “a connector located on the second portion and removably connectable with the electronic device,” as recited in claim 11. Pet. 42. Noguchi instead discloses charging contact points 22 that contact points on rechargeable battery 102. *Id.* at 41 (citing Ex. 1011 ¶ 15; Ex. 1019 ¶ 164). Petitioner argues, however, that it was well known among skilled artisans at the time to include a

App. 55

connector in a cell phone base charger instead of contacts points as described in Noguchi. *Id.* at 42 (citing Ex. 1019 ¶ 166). Petitioner relies on Huang for this teaching. *Id.* Figure 3 of Noguchi and Figure 1 of Huang, reproduced below, each depict a cell phone charging base.

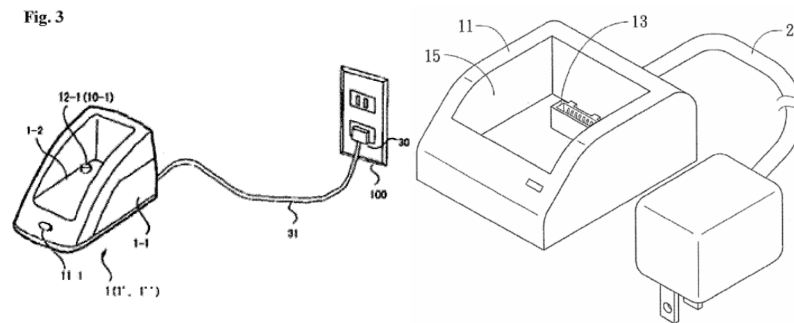

Noguchi Fig. 3 (Ex. 1011) Huang Fig. 1 (Ex. 1013)

Figure 3 of Noguchi depicts a cell phone charging base having main body case 1-1, holder portion 1-2 for setting a cellular telephone, and secondary battery detection switch button 12-1 that when depressed by the weight of a cellular telephone causes contact with switch terminals 12-3 to effectuate electrical transmission and turn on battery detection switch 12. Ex. 1011 ¶¶ 12, 22. Figure 1 of Huang depicts a cell phone charging base 11 having connector 13 disposed on top receptacle 15, wherein connector 13 “is adapted to receive a particular model of cellular telephone 25.” Ex. 1013 ¶3. Huang discloses that cellular telephone 25’s battery charges when connected to connector 13. *Id.*

Petitioner argues a person of ordinary skill in the art would have been motivated to use a connector, as

taught in Huang, in Noguchi’s base cell phone charger to provide a more stable structural connection with a cell phone to prevent the phone from falling or otherwise moving while charging. Pet. 43–44 (citing Ex. 1019 ¶¶ 169–170). Petitioner further argues that it would have been obvious for the base to be a male connector port, as taught in Huang, to be compatible with female power ports in cell phones. *Id.* (citing Ex. 1019 ¶¶ 171–173). According to Petitioner, modifying Noguchi to include the connector taught in Huang would have been nothing more than the combination of known elements in a predictable way to produce predictable results. *Id.* at 44 (citing *KSR*, 550 U.S. at 417). Patent Owner does not make any arguments regarding this claim limitation.

Petitioner also contends that, in the event we construe the claimed “off” state to require a “hard switch” to cut off input power, this feature would have been obvious in view of Suzuki. Pet. 51–54. Petitioner argues a “hard switch” is not required (Reply 22), but provides contingent argument because, according to Petitioner, during reexamination of the ’833 patent, Patent Owner “argued the ‘off’ state requires a ‘hard switch’ to cut off the input power” (Pet. 51–52). Petitioner does not cite where in the extensive reexamination proceeding Patent Owner made this argument. *Id.* The Board did not render a decision on this issue in the reexamination proceeding. *Id.* at 52; *see also generally* Ex. 1004. In this proceeding, Patent Owner does not argue that the claimed “switch assembly” must comprise a hard switch. The language of claim 11, which recites “a

switch assembly having powered terminals,” does not mention or otherwise require a hard switch. Ex. 1001, 12:38. The requirement that the switch assembly be “responsive to movement or at least a movable portion thereof to electrically connect the terminals and to provide an output signal to activate the circuitry to the ‘on’ state,” similarly does not mention a hard switch. *Id.* at 12:38–42. For purposes of this Final Written Decision, we need not, and do not, determine whether claim 11 would have been obvious in view of Suzuki because we do not discern any requirement that the switch assembly comprise a hard switch.

Patent Owner makes various arguments regarding the combination of Noguchi with Suzuki. PO Resp. 27–31. However, because our determination is not based on the combination of Noguchi with Suzuki, Patent Owner’s arguments in this regard do not impact our analysis or our determination.

Petitioner has provided sufficient articulated reasoning with rational underpinning to support the legal conclusion of obviousness as to claim 11. *See KSR*, 550 U.S. at 418. Upon review of the record in this proceeding, we determine that Petitioner has demonstrated by a preponderance of the evidence that claim 11 of the ’833 patent is unpatentable under § 103 as obvious over the combination of Noguchi and Huang.

5. Discussion—Claims 12, 17, 18, 20, and 21

Claims 12, 17, 18, 20, and 21 of the ’833 patent depend directly or indirectly from claim 11. Petitioner

identifies its contentions as to where the limitations of claims 12, 17, 20, and 21 are disclosed in Noguchi and where the limitation of claim 18 is disclosed in Suzuki, and provides argument as to why the relevant disclosures satisfy these claims. Pet. 54–60. Patent Owner does not make any arguments regarding claims 12, 17, 18, 20, and 21 in addition to those for claim 11. PO Resp. 27–31.

a. Claim 12

Claim 12 of the '833 patent recites the power device of claim 11 “wherein the switch assembly movable portion is biased to a first position and is movable to a second position by force applied by the user, cessation of the force permitting the movable portion to return to the first position, the switch assembly producing the output signal only when in the second position.” Ex. 1001, 12:46–51.

With regard to Switch 11, we are persuaded Noguchi discloses “the switch assembly movable portion is biased to a first position” because Noguchi discloses the asserted movable portion, button 11-1, is biased to a first position because a spring applies force that causes the button to rest in a first position. Pet. 55 (citing Ex. 1011 ¶ 20). We are persuaded Noguchi discloses the switch assembly is “movable to a second position by force applied by the user” because Noguchi discloses that when a user presses button 11-1 (e.g., applies force), button 11-1 is moved to a second position. *Id.* (citing Ex. 1011 ¶ 19). We are persuaded Noguchi

discloses “cessation of the force permitting the movable portion to return to the first position” because when a user stops pushing button 11-1 (e.g., cessation of force), button 11-1 returns to the first position. *Id.* (citing Ex. 1011 ¶ 20). We are persuaded Noguchi discloses “the switch assembly producing the output signal only when in the second position” because when button 11-1 is not pressed, “bypass switch 11 is turned off” and no output power is produced when Switch 11 is turned off. *Id.* (citing Ex. 1011 ¶ 20; Ex. 1019 ¶¶ 205–206).

With regard to Switch 12, we are persuaded Noguchi discloses “the switch assembly movable portion is biased to a first position” because Noguchi discloses the asserted movable portion, button 12-1, is held in a first position when not pressed. Pet. 55 (citing Ex. 1011 ¶ 22). We are persuaded Noguchi discloses the switch assembly is “movable to a second position by force applied by the user” because Noguchi discloses that button 12-1 may be “pushed down” (e.g., force is applied) into a second position when telephone 101 is placed in charger 1. *Id.* at 55–56 (citing Ex. 1011 ¶ 22). We are persuaded Noguchi discloses “cessation of the force permitting the movable portion to return to the first position” because when a user removes telephone 101 from charger 1 (e.g., cessation of force), button 12-1 returns to the first position. *Id.* (citing Ex. 1011 ¶ 21). We are persuaded Noguchi discloses “the switch assembly producing the output signal only when in the second position” because when button 12-1 is not pressed, power is turned off. *Id.* at 55 (citing Ex. 1011 ¶ 21; Ex. 1019 ¶¶ 207–208).

b. Claim 17

Claim 17 of the '833 patent recites the power device of claim 11 “wherein the circuitry includes a power sensing portion programmed with a predetermined threshold power level, wherein the circuitry automatically changes to the ‘off’ state in response to the output power being at or below the threshold power level.” Ex. 1001, 13:3–7.

With regard to Switch 11, Petitioner asserts the claimed circuitry includes the combination of Noguchi’s switch 10, converter 20, and control unit 21. Pet. 56 (citing Ex. 1011 ¶ 25). We are persuaded this combination “includes a power sensing portion” because Noguchi discloses this combination includes direct current monitoring means 21-3 that “monitors the direct current output from the converter 20” and second controlling means 21-2 that “controls based on the information relating to the direct current . . . output from the direct current monitoring means 21-3.” *Id.* (citing Ex. 1011 ¶¶ 24–25). We are persuaded Noguchi’s asserted power sensing portion is “programmed with a predetermined threshold power level” because Noguchi discloses this combination determines whether a “predetermined electric current and voltage state” are met, and provides an example of a predetermined state (e.g., threshold) of 0.2 amps and 4.1 volts. *Id.* at 57 (citing Ex. 1011 ¶ 32). We are persuaded Noguchi discloses “the circuitry automatically changes to the ‘off’ state in response to the output power being at or below the threshold power level” because Noguchi discloses switch 10 being turned off when the direct current

App. 61

output from converter 20 reaches a predetermined electric current and voltage state. *Id.* (citing Ex. 1011 ¶¶ 25, 32, 33; Ex. 1019 ¶¶ 212–213).

c. Claim 18

Claim 18 of the '833 patent recites the power device of claim 11 “wherein the circuitry includes a latching relay that is closed in response to the switch assembly output signal, the latching relay being opened in response to the output power being at or below a threshold power level to change the circuitry to the ‘off’ state.” Ex. 1001, 13:8–12.

Petitioner argues it would have been obvious in view of Suzuki to substitute Noguchi’s switch 10 with a latching relay, and refers to arguments for claim 11 regarding this substitution. Pet. 58; *see also id.* at 52–54; Ex. 1019 ¶¶ 193–201. According to Petitioner, the substitution would have been obvious to a skilled artisan because Suzuki teaches that electronic switches, such as those taught in Noguchi, and latching relays are functionally equivalent devices for switching off power draw by circuitry of power saving circuit. Pet. 53; Ex. 1019 ¶ 194. We find the evidence of record supports Petitioner’s assertion.

Noguchi and Suzuki both relate to power saving circuitry that includes a switch to close the AC power supply circuit. Ex. 1012, 1:19–24, 3:17–35; Ex. 1019 ¶ 193. Noguchi’s switch 10 is “interposed between the output side of the AC power supply 100 and the input power side of the converter 20 of the charger inside

App. 62

portion.” Ex. 1011 ¶ 16. Switch 10’s purpose is “transmitting (on) the alternating current input from the AC power supply 100 and cutting the alternating current off (off).” *Id.* Noguchi’s “switch 10 is comprised according to semiconductor switching molecules (electric switch) that can control electrically, such as a relay or a thyristor, and can control the on/off according to the control signal from control unit 21 described below.” Ex. 1011 ¶ 16. Suzuki’s switching element, in one embodiment, comprises a phototriac. Ex. 1012, 3:61–4:16, 19:58–59. Petitioner argues Suzuki teaches the phototriac may be equivalently replaced by an electromagnetic relay (e.g., a latching relay as recited in claims 11 and 18) (Pet. 52 (citing Ex. 1012, 4:35–40, Fig. 2)), and that the electromagnetic relay may be equivalently replaced by a solid state switch (e.g., a switching element like those disclosed in Noguchi) (*id.* (citing Ex. 1012, 4:41–44)).

We are persuaded by Petitioner’s arguments because Suzuki discloses use of a phototriac to switch off power draw, and further discloses the phototriac may be equivalently replaced by an electromagnetic relay, which may be equivalently replaced by a solid state switch. Ex. 1012, 3:27–35, 4:14–27, 4:35–40, 20:15–20, Fig. 1; Pet. 52; Ex. 1019 ¶ 193. Dr. Horenstein opines that using a latching relay in Noguchi would serve the same function as using the disclosed semiconductor switch. Pet. 53; *see also id.* at 54 (citing Ex. 1019 ¶ 201) (arguing a latching relay also draws no power when in the “off” state). Dr. Horenstein opines further that a skilled artisan would have been able to make the

substitution to obtain predictable results. Ex. 1019 ¶ 199; Pet. 54. We are persuaded by the combination of Suzuki's equivalence teachings and Dr. Horenstein's testimony that it would have been obvious to modify Noguchi to use an equivalent switching element such as an electromagnetic relay, as disclosed in Suzuki.

With regard to claim 18's requirement that the latching relay "is closed in response to the switch assembly output signal, the latching relay being opened in response to the output power being at or below a threshold power level to change the circuitry to the 'off' state," Petitioner argues switch 10 performs this function for the reasons expressed regarding claim 17. Pet. 58; *see also id.* at 56–57 (Petitioner's analysis for claim 17). As we discussed with regard to claim 17, we are persuaded Noguchi discloses switch 10 being opened in response to the output power being at or below a threshold power level to change the circuitry to the "off" state. *See supra* Sec. II.G.5.b. Petitioner argues the substitution of switch 10 with Suzuki's latching relay would also perform in this manner. Pet. 58. We are persuaded by Petitioner's argument because the latching relay being substituted for Noguchi's semiconductor switching element is equivalent, and is used to open and close the circuit. The event triggering when the circuit opens, e.g., in response to output power being below or at a threshold, does not impact our analysis.

Patent Owner does not make any arguments specific to claim 18, but makes arguments with respect to

claim 11 regarding the combination of Suzuki and Noguchi. PO Resp. 27–31.

Patent Owner argues the combination of Noguchi with Suzuki is a “re-hash” of arguments Petitioner made during the ’833 reexamination. PO Resp. 27–29. Even if it were, and we do not agree that it is, Petitioner is not estopped under 35 U.S.C. § 315(e) from arguing the combination of Noguchi and Suzuki. *See supra* Section II.D. In any event, we do not agree that Petitioner is re-hashing an argument from the ’833 reexamination. The Decision on Appeal did not disturb the Examiner’s finding that it would have been obvious to modify Noguchi to include Yang’s latching relay. *See generally* Ex. 1004, 13–21. In the reexamination, the issue was whether Yang’s noise removing unit 100 satisfied the limitation “circuitry for converting the input power voltage to the output power voltage,” and more specifically whether removing noise from power voltage qualifies as “converting.” *Id.* at 13. The Board determined it was not shown that noise removal, disclosed in Yang, amounts to converting voltage as required by claim 11. *Id.* at 20. Suzuki is distinguishable from Yang in that Suzuki discloses an AC to DC power converter for converting power voltage. Ex. 1012, 1:27–32. In our claim construction discussion above regarding the term “converting [voltage]” (*see supra* Section II.B.1), we explained that converting AC power (which has an associated voltage power) to DC power (which has an associated voltage power) satisfies the “converting [voltage] limitation.” Accordingly, the combination

with Suzuki is not a “re-hash” of arguments made during the ’833 reexamination.

Patent Owner, in reliance on Dr. Tobias’s testimony, also argues the combination would not have been obvious because a latching relay requires a relay control circuit for controlling the current flowing to a set coil, and cannot be activated by Noguchi’s switch 10. PO Resp. 29 (citing Ex. 2021 ¶ 33). Dr. Tobias’s testimony is unsupported¹² and therefore entitled to little weight. Even if his unsupported testimony were true, namely that a relay control circuit would be required in Noguchi, this fact does not render the combination nonobvious. The appropriate inquiry is not whether this substitution would have required additional design and circuitry, but whether application of the latching relay and additional circuitry would have been beyond the skill of an ordinarily skilled artisan. *See KSR*, 550 U.S. at 417 (“[I]f a technique has been used to improve one device, and a person of ordinary skill in the art would recognize that it would improve similar devices in the same way, using the technique is obvious unless its actual application is beyond his or his skill.”). We find that Suzuki, as a prior art reference, reflects the level of ordinary skill in the art. *Okajima*, 261 F.3d. at 1355. Because Suzuki discloses

¹² Dr. Tobias cites to an entire page of Noguchi to support his statement that the necessity of a relay control circuit “is a consequence of the difference in the control signal between the ‘electric switch’ specified in Noguchi and what would be needed for a latching relay.” He does not identify what disclosure actually supports his opinion, or provide any explanation. We do not discern any express statements supporting his assertion.

equivalence of electronic switches and latching relays (Ex. 1012, 3:27–35, 4:14–27, 4:35–40, 20:15–20, Fig. 1; Pet. 52; Ex. 1019 ¶ 193), we credit Dr. Horenstein’s testimony that it would have been within the ability of an ordinarily skilled artisan to implement a latching relay in Noguchi. Reply 22–23 (citing Ex. 1033 ¶¶ 58–65).

Patent Owner also argues Suzuki teaches away from the ’833 patent, namely from the requirement that in “standby” mode the claimed “circuitry” draws no power. PO Resp. 30–31. Patent Owner premises its argument on Suzuki’s disclosure that in standby mode, Suzuki’s circuit draws 2 to 40 milliwatts of power, whereas “no power,” when properly construed, can be no greater than microwatts of power. *Id.* Patent Owner’s argument is not persuasive because the claim language is silent regarding power draw in a standby mode. The “no power draw” requirement refers to an “off” state. In addition, there is no teaching away because Suzuki does not discourage no power draw when a circuit is in an “off” state. *See Gurley*, 27 F.3d at 53; Reply 24.

Upon consideration of the entirety of the evidence of record, we are persuaded that it would have been obvious in view of Suzuki to use a latching relay in Noguchi.

d. Claim 20

Claim 20 of the ’833 patent recites the power device of claim 11 “wherein the switch assembly is

App. 67

located remote from the first portion.” Ex. 1001, 13:17–18. We are persuaded that both of the asserted switch assemblies, Noguchi’s Switch 11 and Switch 12, are located remote from the asserted first portion, Noguchi’s plug 30, because Switch 11 and Switch 12 are located on body 1-1, which is distant from plug 30 and separated from plug 30 by cable 31. Pet. 59 (citing Ex. 1011 ¶ 12, Fig. 3; Ex. 1019 ¶¶ 226–229).

e. Claim 21

Claim 21 of the ’833 patent recites the power device of claim 20 “wherein the switch assembly is located proximate to the second portion.” Ex. 1001, 13:19–20. We are persuaded both of the asserted switch assemblies, Noguchi’s Switch 11 and Switch 12, are located proximate to the asserted second portion, Noguchi’s main body case 1-1, because Switch 11 and Switch 12 are located on main body case 1-1 and therefore proximate to case 1-1. Pet. 59–60 (citing Ex. 1011 ¶¶ 12, 22; Ex. 1019 ¶¶ 233–236).

f. Conclusion

Petitioner has provided sufficient articulated reasoning with rational underpinning to support the legal conclusion of obviousness as to claims 12, 17, 18, 20, and 21 under a preponderance of the evidence standard. *See KSR*, 550 U.S. at 418; 35 U.S.C. § 316(e). For reasons we discussed with regard to claim 11, a hard switch is not required, and therefore Suzuki is not needed for a finding of obviousness with regard to

claims 12, 17, 20, and 21. *See supra* Section II.G.4. Upon review of the record in this proceeding, we determine that Petitioner has demonstrated by a preponderance of the evidence that claims 12, 17, 20, and 21 of the '833 patent are unpatentable under § 103 as obvious over the combination of Noguchi and Huang, and that claim 18 is unpatentable under § 103 as obvious over the combination of Noguchi, Huang, and Suzuki.

*H. Asserted Obviousness of Claim 16 over
Noguchi, Huang, Suzuki, and Byun*

Petitioner contends claim 16 of the '833 patent is unpatentable as obvious over the combination of Noguchi, Huang, Suzuki, and Byun. Pet. 7, 60–62. Patent Owner disputes Petitioner's contention. PO Resp. 31–34. In our Institution Decision, we instituted based on the combination of Noguchi, Huang, and Byun, with or without Suzuki. Inst. Dec. 29–30, 34. We have reviewed the full record from trial, and we determine that Petitioner has shown by a preponderance of the evidence that claim 16 of the '833 patent is unpatentable as obvious over the combination of Noguchi, Huang, and Byun.

1. Overview of Byun (Ex. 1014)

Byun is a Korean Public Patent Application, published on January 27, 2006. Ex. 1014, [43]. Based on the earliest possible priority date of the '833 patent (*see supra* Section I.C), we conclude that Byun is prior art to the '833 patent under 35 U.S.C. § 102(b).

Byun generally relates to “the structure of the standby power saving push switch.” Ex. 1014, 5.¹³ Byun discloses that in home appliances such as a television (“TV”), “when the main power is turned off, standby mode is maintained by supplying power to minimal functionality block circuits” to “support advanced functionalities like remote control and reservations through a timer.” *Id.* at 6. Byun discloses that during standby mode, even though main power is turned off, a small amount of energy use still occurs. *Id.* According to Byun, “energy used during the standby mode is smaller than during the active mode,” but “if energy used during the standby mode is added up, we can see that a significant amount of energy is utilized.” *Id.* To address the issue of energy use during standby mode, Byun discloses a structure that “reduce[s] the energy use during standby mode by controlling push switches that turn power On/Off with an electric signal.” *Id.* In particular, Byun uses a timer that keeps track of time after standby mode is entered. *Id.* at 7. When a predetermined time has lapsed, an electric signal is sent to button release unit (22) to release the button, thereby causing push switch (20) to shut off power such that “the entire system power supply is turned off.” *Id.* “Therefore, energy usage during the standby mode can be prevented.” *Id.* Byun states that in this manner, the invention “blocks energy use during the standby mode to prevent unnecessary use of energy.” *Id.*

¹³ Petitioner cites to the Bates No. of Exhibit 1014, rather than to the original document’s page number. To avoid confusion, we adopt Petitioner’s citation convention.

2. *Discussion*

Claim 16 further recites the power device of claim 11, “wherein the circuitry includes a timer programmed with a predetermined time period, the timer providing a timer signal to the circuitry at the conclusion of the time period, and the circuitry automatically changes to the ‘off’ state in response to the timer signal.” Ex. 1001, 12:65–13:2. The ’833 patent provides an example of this feature, disclosing a timer so that a slight temporal pause in power will not cause switch 210 to open, thereby shutting off power. Ex. 1001, 9:29–38, 9:7–10. Petitioner acknowledges Noguchi does not disclose the claimed feature at issue. Pet. 61. In Noguchi, control unit 21 automatically changes to the “off” state (i.e., turns switch 10 off) in response to removing the cell phone from the charging base, rather than in response to a timer. Pet. 60 (citing Ex. 1011 ¶ 27). Petitioner argues that Byun, however, teaches using a timer so that the device is not turned “off” automatically when a user switches the device to standby mode, but rather switches to “off” only after a certain amount of time has lapsed after switching to standby mode. *Id.* at 61 (citing Ex. 1014, 7). According to Petitioner, it would have been obvious to incorporate Byun’s timer and timer signal into Noguchi’s control unit 21 to allow for delay before turning switch 10 off in response to removing a cell phone from the charging base. *Id.* Petitioner argues this would prevent unnecessarily shutting “off” power if the cell phone is inadvertently removed from or knocked out of the charging base and

placed back in the base within a predetermined time period. *Id.* at 61–62 (citing Ex. 1019 ¶¶ 246–252).

Dr. Horenstein opines that a skilled artisan would have recognized the benefit of Byun’s time lapse feature would have been to prevent opening the circuit unnecessarily. Ex. 1019 ¶ 249. We find Dr. Horenstein’s testimony is supported by Byun’s disclosure that switching to an “off” state after a predetermined amount of time lapses “prevent[s] unnecessary use of energy” (Ex. 1014, 6–7), and find it reasonable that a skilled artisan would have understood the advantage of having Byun’s timer would have been to wait a predetermined amount of time for an event to occur, and only opening the circuit (hence switching to an “off” state) if the event does/does not occur within the predetermined time period, to avoid unnecessarily opening the circuit. We therefore find reasonable Dr. Horenstein’s testimony that a skilled artisan would have recognized that in Noguchi’s system, it would have been beneficial to include Byun’s timer to avoid unnecessarily switching Noguchi’s power device to an “off” state prior to allowing a predetermined amount of time to lapse. Ex. 1019 ¶ 251.

Patent Owner argues the combination of Noguchi and Byun would not have been obvious based on its contention that Byun operates differently from what is recited in claim 11, from which claim 16 directly depends. PO Resp. 32. Specifically, Patent Owner argues claim 11 refers to only two states of operation, an “on” state and an “off” state, whereas Byun discloses three operational states, “on,” “off,” and “standby.” *Id.* (citing

Ex. 2021 ¶ 39). Patent Owner argues the timer in Byun does not start counting time unless it is standby mode, and therefore, does not teach switching between an “on” and “off” state through the use of a timer, as recited in claim 16. *Id.* (citing Ex. 2021 ¶ 39). Patent Owner argues that because Byun requires an intermediate state between “off” and “on,” namely “standby,” a person of ordinary skill in the art at the time would not have incorporated Byun’s timer in Noguchi that has only “on” and “off” states. *Id.* at 33–34 (citing Ex. 2021 ¶¶ 40–45). We disagree with Patent Owner’s assessment.

Petitioner acknowledges Noguchi discloses only an “on” state and “off” state, but argues it would have been obvious in view of Byun to include a “standby” mode during which time a timer counts time in order to avoid unnecessarily shutting off power entirely, for example if the cell phone is accidentally knocked out of the base and returned to the base within a predetermined amount of time. Reply 25–26; Pet. 60–62. Even if Noguchi were not modified to include a “standby” mode, “[t]he test for obviousness is not whether the features of a secondary reference may be bodily incorporated into the structure of the primary reference. . . . Rather, the test is what the combined teachings of the references would have suggested to those of ordinary skill in the art.” *In re Keller*, 642 F.2d 413, 425 (CCPA 1981); *see also In re Sneed*, 710 F.2d 1544, 1550 (Fed. Cir. 1983) (“[I]t is not necessary that the inventions of the references be physically combinable to render obvious the invention under review.”); *In re Nievelt*, 482

F.2d 965, 968 (CCPA 1973) (“Combining the *teachings* of references does not involve an ability to combine their specific structures.”). Rather, “if a technique has been used to improve one device, and a person of ordinary skill in the art would recognize that it would improve similar devices in the same way, using the technique is obvious unless its actual application is beyond his or her skill.” *KSR*, 550 U.S. at 417. Accordingly, it is sufficient for Petitioner to show a skilled artisan would have used Byun’s timing technique in Noguchi to determine when to switch to an “off” state.

We find the standby state in Byun is similar to the “on” state in Noguchi in that power is drawn, albeit less power than when in an “on” state. Ex. 1014, 6 (“[E]nergy used during the standby mode is smaller than during the active mode. But if energy used during the standby mode is added up, we can see a significant amount of energy is utilized.”). Byun, like Noguchi, teaches opening the system switch to put the system in an “off” state to prevent further power draw. *See* Pet. 61 (citing Ex. 1019 ¶ 249); *see also* Ex. 1014, 6–7 (“Therefore, energy usage during the standby mode can be prevented,” “when the predetermined time lapses, by sending an electric signal to the button release unit in the push switch that provides the main power supply to release the button, it blocks energy use during the standby mode to prevent unnecessary use of energy.”). We therefore find Byun’s teaching of using a timer to determine when to switch from standby mode to an “off” state also would have been beneficial when determining when to switch from an “on” state

to an “off” state to prevent further power draw. Ex. 1019 ¶ 250. Accordingly, we are persuaded it would have been obvious to include Byun’s timing feature in Noguchi to determine when to switch to an “off” state to prevent unnecessarily switching to the “off” prior to allowing a predetermined amount of time to lapse.

Patent Owner’s argument that Byun’s timer would not function in Noguchi lacks support. PO Resp. 33–34. Patent Owner argues that the combination “would not draw zero power.” *Id.* Patent Owner relies solely on one paragraph of testimony of Dr. Tobias. *Id.* (citing Ex. 2021 ¶ 45). The testimony in its entirety states “[m]oreover, the system that Byun proposes would not effectively draw near-zero power as described by ’833 patent. Some power overhead would be needed for Byun’s timer circuitry to function.” Ex. 2021 ¶ 45. Such unsupported testimony is entitled to little or no weight. 37 C.F.R. § 42.65(a). Neither Patent Owner nor Dr. Tobias cite any evidence that the timing circuitry implemented in Noguchi would be placed upstream of the primary transformer winding, and therefore would draw power in an “off” state. As pointed out by Petitioner, the timing circuitry “would only function in the ‘standby period’ before all power was cutoff. The timer does not operate in the ‘off state’ . . . and the timer draws no power in the ‘off state.’” Reply 26–27 (citing Ex. 1033 ¶ 82). The evidence, therefore, supports Petitioner’s obviousness contention.

Petitioner has provided sufficient articulated reasoning with rational underpinning to support the legal conclusion of obviousness as to claim 16. *See KSR*, 550

U.S. at 418. For reasons we discussed with regard to claim 11, a hard switch is not required by claim 16, and therefore Suzuki is not needed for a conclusion of obviousness. *See supra* Section II.G.4. Upon review of the record in this proceeding, we determine that Petitioner has demonstrated by a preponderance of the evidence that claim 16 of the '833 patent is unpatentable under § 103 as obvious over the combination of Noguchi, Huang, and Byun.

*I. Asserted Obviousness of Claim 22 Over Noguchi, Huang, Sakamoto, Odaohhara, and Suzuki*¹⁴

Petitioner contends claim 22 of the '833 patent is unpatentable as obvious over the combination of Noguchi, Huang, Sakamoto, Odaohhara, and Suzuki. Pet. 7, 62–69. Patent Owner incorporates by reference its arguments regarding claim 4 of the '833 patent, which we address above, *see supra* Section II.F, but does not otherwise dispute Petitioner's contentions. PO Resp. 34–35. In our Institution Decision, we instituted based on the combination of Noguchi and Huang, with or without Suzuki. Inst. Dec. 31–32, 34. We have reviewed the full record from trial, and we determine that Petitioner has shown by a preponderance of the evidence that claim 22 of the '833 patent is unpatentable as

¹⁴ Although Petitioner omits Huang from the section heading (Pet. 62), claim 22 depends from claim 11, which Petitioner argues is rendered obvious by the combination of Noguchi and Huang (*id.* at 39–54). As a result, we regard Petitioner's omission of Huang from the section heading as harmless error.

obvious over the combination of Noguchi, Huang, Sakamoto, and Odaohhara.

Claim 22 recites the power device of claim 11 “wherein the switch assembly comprises a sheath longitudinally movable to and between first and second positions, wherein the first position corresponds to the ‘on’ state.” Ex. 1001, 13:22–25. With respect to charging a cell phone, Noguchi describes charging case 1-1 having a user activated push button switch 12 adjacent to charging points 22, which charges battery 102 when battery 102 comes into contact with charging points 22. Pet. 62–63 (citing Ex. 1011 ¶¶ 15, 18, 20, 22). Noguchi teaches, however, that “the present invention is not limited to a charger for a cellular telephone,” and contemplates charging a battery for laptop computers. *Id.* at 64 (citing Ex. 1011 ¶¶ 2, 69). Petitioner argues a person of ordinary skill in the art would have recognized a laptop computer would not have fit in charging case 1-1, and therefore would have been motivated to modify the charger in Noguchi to allow for powering a laptop when a laptop is connected to the charger. *Id.* Sakamoto teaches using a charging pedestal to charge a cell phone, similar to Noguchi’s case 1-1, to charge a cell phone. *Id.* (citing Ex. 1009 ¶ 24, Figs. 4–6). Sakamoto also teaches using a cord with a plug, having a switch assembly at the end of DC plug 3, for charging a laptop computer. *Id.* at 65–66 (citing Ex. 1009 ¶ 27, Figs. 1, 6). According to Petitioner, a skilled artisan would have been motivated, therefore, to modify Noguchi to use a cord with a switch assembly at the end that connects with a DC powered device such as a laptop

computer. *Id.* at 67. Petitioner argues further that a skilled artisan would have been motivated to include the claimed “connector” that is “removably connectable with the electronic device,” in the form of Sakamoto’s terminal 31. *Id.* at 68. We find Petitioner’s arguments persuasive because Noguchi contemplates charging a laptop computer, and Sakamoto teaches the use of terminal 31 and a cord, rather than a pedestal, to charge a laptop computer, as well as the desirability of placing the switching mechanism at the end of the cord.

Petitioner argues further that it would have been obvious in view of Odaohhara to modify pin 34 of Sakamoto to comprise a sheath, for the same reasons Petitioner argues with respect to claim 4. Pet. 68–69. Patent Owner argues the combination proposed by Petitioner is nonobvious for the same reasons argued with regard to claim 4, and incorporates those arguments by reference. PO Resp. 34–35. For the reasons we discussed with respect to claim 4, we are persuaded by Petitioner’s arguments. *See supra* II.F.3.

Petitioner has provided sufficient articulated reasoning with rational underpinning to support the legal conclusion of obviousness as to claim 22. *See KSR*, 550 U.S. at 418. For reasons we discussed with regard to claim 11, a hard switch is not required by claim 22, and therefore Suzuki is not needed for a conclusion of obviousness. *See supra* Section II.G.4. Upon review of the record in this proceeding, we determine that Petitioner has demonstrated by a preponderance of the evidence that claim 22 of the ’833 patent is unpatentable under

§ 103 as obvious over the combination of Noguchi, Huang, Sakamoto, and Odaohhara.

J. Patent Owner's Motion to Exclude

Patent Owner filed a Motion to Exclude Evidence (Paper 29), Petitioner filed an opposition thereto (Paper 32), and Patent Owner filed a reply (Paper 33). Patent Owner seeks to exclude paragraphs 4–13 of the Declaration of Andrew S. Flior (Ex. 1018, “the Flior Declaration”), which relate to prior art searches relating to the '833 patent obtained by Mr. Flior's law firm. This evidence relates to arguments we need not, and do not, address regarding whether Petitioner is estopped under 35 U.S.C. § 315(e) from bringing this *inter partes* review. *See supra* Section II.D. Because we do not rely on, or reference, paragraphs 4–13 of the Flior Declaration in our Final Written Decision, Patent Owner's Motion to Exclude Evidence is dismissed as moot.

III. SUMMARY

For the foregoing reasons, we determine that Petitioner has demonstrated, by a preponderance of the evidence, that the Challenged Claims are unpatentable under 35 U.S.C. § 103(a) as obvious over the following combinations: claim 4 over Sakamoto and Odaohhara; claims 11, 12, 17, 20, and 21 over Noguchi and Huang; claim 18 over Noguchi, Huang, and Suzuki; claim 16 over Noguchi, Huang, and Byun; and claim 22 over Noguchi, Huang, Sakamoto, and Odaohhara.

IV. ORDER

Accordingly, it is:

ORDERED that claims 4, 11, 12, 16–18, and 20–22 of the '833 patent have been shown to be unpatentable;

FURTHER ORDERED that Patent Owner's Motion to Exclude (Paper 29) is dismissed as moot; and

FURTHER ORDERED that, because this is a Final Written Decision, parties to the proceeding seeking judicial review of the decision must comply with the notice and service requirements of 37 C.F.R § 90.2.

PETITIONER:

Ketan Vakil
Andrew Flior
SNELL & WILMER L.L.P
kvakil@swlaw.com
aflior@swlaw.com

PATENT OWNER:

Jerold I. Schneider
Kevin E. Cudlipp
Schneider Rothman Intellectual
Property Law Group, PLLC
jerold.schneider@sriplaw.com
kevin.cudlipp@sriplaw.com

App. 80

UNITED STATES PATENT AND
TRADEMARK OFFICE

BEFORE THE PATENT TRIAL
AND APPEAL BOARD

SUPERIOR COMMUNICATIONS, INC.,
Petitioner,

v.

VOLTSTAR TECHNOLOGIES, INC.,
Patent Owner.

Case IPR2017-00067
Patent 7,910,833 B2

Before MATTHEW R. CLEMENTS, KERRY BEGLEY,
and CHRISTA P. ZADO, *Administrative Patent Judges*.

ZADO, *Administrative Patent Judge*.

DECISION

Institution of *Inter Partes* Review
37 C.F.R. § 42.108

I. INTRODUCTION

A. *Background*

Superior Communications, Inc. (“Petitioner”) filed a Petition requesting an *inter partes* review of claims 1–4, 6–12, 16–18, 20–22, and 56–58 of U.S. Patent No. 7,910,833 B2 (Ex. 1001, the ’833 patent) pursuant to

35 U.S.C. §§ 311–319. Paper 1 (“Pet.”). Voltstar Technologies, Inc. (“Patent Owner”) filed a Re-Filed Preliminary Response to the Petition. Paper 10 (“Prelim. Resp.”).

Pursuant to 35 U.S.C. § 314, an *inter partes* review may not be instituted “unless . . . the information presented in the petition . . . shows that there is a reasonable likelihood that the petitioner would prevail with respect to at least 1 of the claims challenged in the petition.” 35 U.S.C. § 314(a). Upon considering the record developed thus far, for reasons discussed below, we institute *inter partes* review of the ’833 patent as to challenged claims 4, 11, 12, 16–18, and 20–22. This is not a final decision as to patentability of the claims of the ’833 patent. Our final decision will be based on the record as fully developed during trial.

B. Additional Proceedings (37 C.F.R. § 42.8(b)(2))

Petitioner indicates Patent Owner previously filed a district court action against non-parties to this proceeding asserting the ’833 patent on February 29, 2012: *VoltStar Technologies, Inc. v. AT&T Inc. et al*, Case No. 2: 12-cv-00082-JRG (E.D. Tex.). Pet. 3. Thereafter, on September 14, 2012, Petitioner filed a petition requesting *inter partes* reexamination of the ’833 patent, Reexamination Control No. 95/002,365. *Id.* at 1; *see also* Ex. 1020 (request for reexamination). Petitioner indicates Patent Owner subsequently filed a district court action against Petitioner on February 1, 2013, asserting the ’833 patent: *VoltStar Technologies,*

Inc. v. Superior Communications, Case No. 2:13-cv-00097-JRG (E.D. Tex.). Pet. 3.

On August 2, 2013, in the reexamination proceeding, the Examiner issued a Right of Notice of Appeal rejecting claims 1–23 and 56–58 of the '833 patent, and finding claims 24–27 and 33–37 patentable. *Id.* at 1–2 (citing Ex. 1003, 3). On October 3, 2013, both district court actions were dismissed without prejudice at the parties' request, pursuant to Federal Rule of Civil Procedure 41(a). Pet. 3–4; *see also* Ex. 1008 (dismissal order).

Petitioner appealed the Examiner's validity findings in the reexamination, and Patent Owner cross-appealed the Examiner's invalidity findings, to the Board. Pet. 2. On December 10, 2014, the Board issued a Corrected Decision on Appeal in which the Board, in pertinent part, affirmed the rejection of claims 1–3, and rejected claims 6–10 and 56–58 on new grounds. *Id.* (citing Ex. 1004, 71–72). Petitioner appealed the Board's decision to the United States Court of Appeals for the Federal Circuit ("Federal Circuit"), Case No. 2016-1204 (*id.*), and Patent Owner filed a cross-appeal, Case No. 2016-1205, which Patent Owner later dismissed voluntarily (Paper 13, 1). The Federal Circuit issued its decision in the appeal on February 13, 2017, after the filing of the Petition in the instant proceeding, affirming the Board's decision pursuant to Federal Circuit Rule 36. Paper 13, 1; *see also* Ex. 3001 (Federal Circuit decision).

Petitioner also indicates Patent Owner filed a district court action against Petitioner asserting the '833 patent on October 19, 2016 (after the Petition was filed in the instant proceeding), *VoltStar Technologies, Inc. v. AT&T Mobility, LLC et al.*, Case No. 2:16-cv-01181-JRG (E.D. Tex.), and further indicates the district court action has been stayed until August 1, 2017. Paper 13, 1–2.¹

Petitioner also indicates *inter partes* reexamination proceedings regarding patents related to the '833 patent have concluded, namely reexamination of U.S. Patent No. 8,242,359, Reexamination Control No. 95/002,374, and of U.S. Patent No. 7,960,648, Reexamination Control No. 95/002,378. Pet. 2–3.

C. The '833 Patent

The '833 patent generally relates to a power device, such as an alternating current (“AC”) adapter, for charging portable electronic devices. Ex. 1001, Abstract. More specifically, the power device includes a power shut off feature to prevent the power device from continuing to draw power (i.e., phantom load) from an AC outlet when the electronic device becomes

¹ The parties failed to comply with their obligations pursuant to 37 C.F.R. §§ 42.8(a)(3) and 42.8(b)(2) to inform the Board of the filing of the district court action within 21 days. For example, Patent Owner filed Mandatory Notices on November 9, 2016, after filing the October 19th district court action, and failed to mention the district court action. Paper 5. The parties are obligated to comply with 37 C.F.R. § 42.8 during this proceeding.

App. 84

fully charged or is removed from the power device. *Id.* at 1:6–11, 1:63–2:3.

The '833 patent describes, for example, power device 10, depicted in Figures 1–2. Figures 1 and 2 are reproduced below:

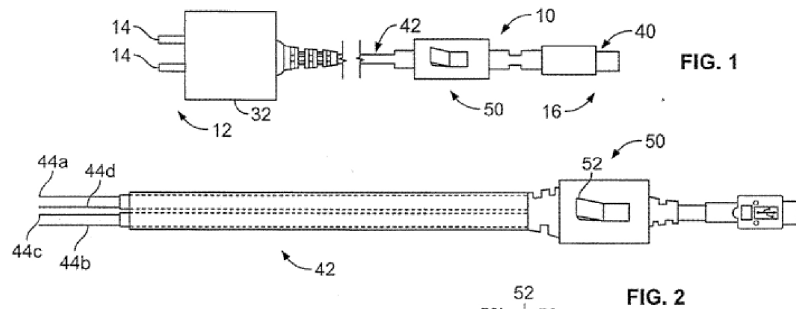

Ex. 1001, Figs. 1, 2. Figure 1 depicts power device 10 having first end 12 comprising prongs 14 that are inserted into a power outlet that provides electrical power in order to power device 10. Ex. 1001, 6:57–61. Second end 16 is depicted as comprising connector 40 for connecting with electronic device 20, such as a cell phone, in order to recharge device 20. *Id.* at 6:61–7:3. Depicted in Figure 2, switch assembly 50 comprises rocker or toggle throw 52 for switching power device 10 between an “on” state in which power may be delivered to device 20, and an “off” state in which power draw is zero or negligible, e.g., when device 20 is fully charged or disconnected from power device 10. *Id.* at 6:42–47, 7:37–46. Power device 10 also includes circuitry 30, not shown in Figures 1 and 2, for converting input power received at prongs 14 into output power delivered to electronic device 20. *Id.* at 7:4–12, Fig. 8. The '833 patent discloses that “[i]n order to be a true ‘zero-energy’

device the power input (i.e., AC input) to the power device must be cut.” *Id.* at 2:53–54. Moreover, the point at which the circuit in the power device circuitry is opened is important because “[t]he portion of a charger/adapter that is most directly responsible for power draw or phantom load are a switcher IC chip 210 (see FIG. 8), a transformer T (see FIG. 8), and components downstream therefrom.” *Id.* at 8:20–35. Accordingly, in a preferred embodiment, transformer T is downstream of switch terminals 50a and 50b, and therefore unable to draw power when switch terminals 50a and 50b are open, i.e., power device 10 is in an “off” state. *Id.* at 8:5–35.

D. Challenged Claims of the ’833 Patent

Of the challenged claims noted above, claims 1, 11, and 56 are independent, and claims 2–4, 6–10, 12, 16–18, 20–22, 57, and 58 depend therefrom.

Claim 11, reproduced below, is illustrative:

11. A power device for supplying power to a portable rechargeable electronic device, the power device comprising:

a first portion for receiving electrical input power from a source, the input power having an input voltage;

a second portion for delivering electrical output power to the electronic device, the output power having an output voltage;

App. 86

circuitry for converting the input power voltage to the output power voltage and for determining an “off” state of the circuitry;

a connector located on the second portion and removably connectable with the electronic device; and

a switch assembly having powered terminals, the switch assembly responsive to movement or at least a movable portion thereof to electrically connect the terminals and to provide an output signal to activate the circuitry to the “on” state,

wherein the circuitry automatically turns the circuitry to the “off” state, the circuitry drawing no power when in the “off” state.

E. Asserted Grounds of Unpatentability

Petitioner contends the challenged claims are unpatentable on the following grounds (Pet. 6–7):

Challenged Claim(s)	Basis	Reference(s)
1–3, 6–10, 56–58	§ 102	Sakamoto ²
4	§ 103	Sakamoto and Odaohhara ³

² Patent Application Disclosure JP 2003-284342 (Ex. 1009) (“Sakamoto”). Exhibit 1009 includes an English translation at pages 8–21.

³ U.S. Patent No. 6,986,067 B2 (Ex. 1010) (“Odaohhara”).

11, 12, 17, 18, 20, 21	§ 103	Noguchi ⁴ , Suzuki ⁵ , and Huang ⁶
16	§ 103	Noguchi, Suzuki, Huang, and Byun ⁷
22	§ 103	Noguchi, Suzuki, Sakamoto, and Odaohhara
11, 12, 17, 18, 20, 21	§ 103	Eishi ⁸ and Luu ⁹

II. ANALYSIS

A. Claim Construction

In an *inter partes* review, claim terms in an unexpired patent are given their broadest reasonable interpretation in light of the specification of the patent in which they appear. *See* 37 C.F.R. § 42.100(b); *Cuozzo Speed Techs., LLC v. Lee*, 136 S. Ct. 2131, 2144–45 (2016) (upholding the use of the broadest reasonable interpretation standard). Under the broadest reasonable interpretation standard, claim terms are presumed to have their ordinary and customary meaning, as

⁴ Patent Application Disclosure JP 2002-199612 (Ex. 1011) (“Noguchi”). Exhibit 1011 includes an English translation at pages 15–36.

⁵ U.S. Patent No. 6,489,725 B1 (Ex. 1012) (“Suzuki”).

⁶ U.S. Patent Publication No. 2002/0115480 A1 (Ex. 1013) (“Huang”).

⁷ Public Patent Application KR 10-2006-0008699 (Ex. 1014) (“Byun”). Exhibit 1014 includes an English translation at pages 5–8.

⁸ Patent Application Disclosure JP 2002-125315 (Ex. 1015) (“Eishi”). Exhibit 1015 includes an English translation at pages 9–22.

⁹ U.S. Patent No. 7,140,922 B2 (Ex. 1016) (“Luu”).

would have been understood by one of ordinary skill in the art in the context of the entire patent disclosure. *In re Translogic Tech., Inc.*, 504 F.3d 1249, 1257 (Fed. Cir. 2007).

Petitioner proposes a construction for the term “output signal.” Pet. 14–15. Patent Owner does not dispute Petitioner’s proposed construction, nor does Patent Owner propose any other terms for construction. Based on the current record, we determine no claim terms need to be construed expressly at this time because the parties have not raised any controversies necessitating construction. *See Vivid Techs., Inc. v. Am. Sci. & Eng’g, Inc.*, 200 F.3d 795, 803 (Fed. Cir. 1999) (holding that claim terms need only be interpreted to the extent necessary to resolve the controversy).

B. 35 U.S.C. § 315(b)

Patent Owner asserts we should deny institution of *inter partes* review pursuant to 35 U.S.C. § 315(b) because Petitioner filed the Petition in the instant proceeding more than one year after it was served with a complaint alleging infringement of the ’833 patent. Prelim. Resp. 8–13. In particular, Patent Owner alleges Petitioner was served with a complaint on or about February 1, 2013. *Id.*

Section 315(b) provides that:

An *inter partes* review may not be instituted if the petition requesting the proceeding is filed more than 1 year after the date on which the petitioner, real party in interest, or privy

of the petitioner is served with a complaint alleging infringement of the patent.

Petitioner does not dispute that it was served with a complaint alleging infringement of the '833 patent more than one year prior to filing the Petition in the instant proceeding. Pet. 3–5. Petitioner argues, however, that the instant proceeding is not barred under § 315(b) because the district court action resulting from the earlier-filed complaint was dismissed without prejudice pursuant to Federal Rule of Civil Procedure 41(a), leaving the parties “as though the action had never been brought.” Pet. 5 (citing *Ariosa Diagnostics v. Isis Innovation Ltd.*, Case IPR2012-00022, slip op. at 17 (PTAB Sept. 2, 2014) (Paper 166)); *see also* Ex. 1008 (dismissal order). As we have noted in previous Board decisions, the “Federal Circuit has consistently interpreted the effect of such dismissals as leaving the parties as though the action had never been brought.” *Macauto U.S.A. v. Bos GmbH & KG*, Case IPR2012-00004, slip op. at 15 (PTAB Jan 24, 2013) (Paper 18) (citing *Graves v. Principi*, 294 F.3d 1350, 1356 (Fed. Cir. 2002); *Bonneville Assocs., Ltd. P’ship v. Baram*, 165 F.3d 1360, 1364 (Fed. Cir. 1999)). Because the effect of a voluntary dismissal without prejudice is to render the prior action a nullity, such action does not give rise to a statutory bar under 35 U.S.C. § 315(b).

Patent Owner attempts to distinguish the present case on grounds that the parties entered into an agreement (Tolling Agreement, Ex. 2010), as a result of the district court action, in which Patent Owner gave away certain rights. Prelim. Resp. 8–13. Patent Owner

argues that it is obligated under the Tolling Agreement to terms that never would have been imposed on it had the district court action never been brought. *Id.* at 12–13. Even assuming *arguendo* that the parties never would have agreed to the terms of the Tolling Agreement absent the district court action, the Tolling Agreement does not change the *de jure* legal effect of the dismissal, which dismisses “all claims, counterclaims, and affirmative defenses asserted in th[e] litigation [] without prejudice.” Ex. 1008. Patent Owner directs us to no authority holding that a contractual agreement between private parties can alter the legal effect of a voluntary dismissal without prejudice. Nor do we consider the Board’s decisions cited by Patent Owner to mandate a different outcome. In *LG Electronics, Inc. v. Mondis Technology Ltd.*, the complaint was not dismissed without prejudice as to all claims. In particular, the claims with respect to computer monitors were dismissed *with* prejudice. *LG Elecs., Inc. v. Mondis Tech. Ltd.*, Case IPR2015-00937, slip op. at 6 (PTAB Sept. 17, 2015) (Paper 8). In the present proceeding, by contrast, all claims in the district court action were dismissed *without* prejudice. Ex. 1008. In *Histologics, LLC v. CDx Diagnostics, Inc.*, the patent infringement claims of the dismissed action were consolidated into another district court action where the parties continued to litigate those claims. *Histologics, LLC v. CDx Diagnostics, Inc.*, Case IPR2014-00779, slip op. at 5 (PTAB Sept. 12, 2014) (Paper 6). Again, that is not the case here.

Patent Owner attempts to argue the district court action alleging infringement of the '833 patent filed after the Petition in the instant proceeding is “litigation stemming from” the earlier-filed complaint, but we disagree. Prelim. Resp. 11–12. As noted above, all claims of the earlier-filed complaint were dismissed without prejudice; therefore, the new complaint does not stem from the earlier-filed complaint. Patent Owner argues also that Petitioner is still subject to the jurisdiction of the court in which the original complaint was filed “through enforcement of the tolling agreement and the identical claims brought in” a case that was consolidated with the earlier-filed action. *Id.* The consolidated action, however, also was dismissed *without* prejudice. Ex. 1008. Moreover, Patent Owner has cited nothing that shows the Tolling Agreement or the parties are subject to any particular jurisdiction.

In sum, notwithstanding the Tolling Agreement, we determine that the complaint filed in 2013 and subsequently voluntarily dismissed without prejudice does not give rise to a statutory bar under § 315(b).

C. Asserted Anticipation of Claims 1–3, 6–10, and 56–58 by Sakamoto

The Federal Circuit affirmed the cancellation of claims 1–3, 6–10, and 56–58 of the '833 patent resulting from reexamination. *See* Ex. 3001 (decision affirming Corrected Decision on Appeal issued by the Board); *see also* Ex. 1004 (Corrected Decision on Appeal issued by the Board). In addition, Patent Owner filed a

disclaimer, pursuant to 35 U.S.C. § 253 and 37 C.F.R. § 1.321, disclaiming claims 1–3, 6–10, and 56–58 of the '833 patent. Prelim. Resp. 14; Ex. 2013 (disclaimer). A patentee may “make disclaimer of any complete claim Such disclaimer shall be in writing and recorded in the Patent and Trademark Office.” 35 U.S.C. § 253. Further, 37 C.F.R. § 42.107(e) provides that the “patent owner may file a statutory disclaimer under 35 U.S.C. 253(a) in compliance with § 1.321(a) of this chapter, disclaiming one or more claims in the patent. No *inter partes* review will be instituted based on disclaimed claims.” Accordingly, we do not institute *inter partes* review of claims 1–3, 6–10, and 56–58 of the '833 patent.

D. Asserted Obviousness of Claim 4 over Sakamoto and Odaohhara

Petitioner asserts claim 4 of the '833 patent is unpatentable as obvious over Sakamoto and Odaohhara. Pet. 36–39. Petitioner submits a declaration of Dr. Mark Horenstein in support of the Petition. Ex. 1019. Patent Owner disputes Petitioner's assertion of unpatentability. Prelim. Resp. 19–20. For reasons that follow, we institute an *inter partes* review of claim 4 on the ground of obviousness over Sakamoto and Odaohhara.

1. Overview of Sakamoto (Ex. 1009)

Sakamoto, like the '833 patent, relates to an adapter for converting power from a commercial power

source to power for an electronic device such as a computer or cell phone, wherein the adapter can be switched to an “off” state in which the adapter does not consume power from the commercial power source. Ex. 1009, Abstract, ¶ 1. Sakamoto discloses an adapter for converting AC power to direct current (DC) power, the conversion circuitry including transformer 21, rectifier circuit 22, and smoothing circuit 23. *Id.* at Abstract. According to Sakamoto, conventional AC adapters have the problem that even when the AC adapter is not being used to charge an electronic device, the adapter continues to draw power from the commercial power source because the primary winding of the transformer is still connected to the power source. *Id.* ¶ 3. In order to address the stated problem, Sakamoto discloses providing a switch connected to a circuit of the primary winding of the transformer and a switch on the electronic device side, so that when open, the transformer cannot draw power. *Id.* ¶¶ 4–7. Figures 1 and 2 of Sakamoto are reproduced below.

[FIG. 1]

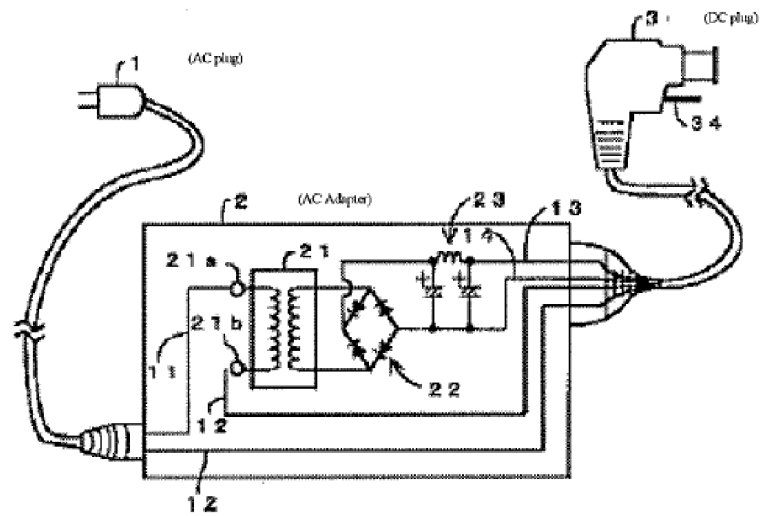

[FIG. 2]

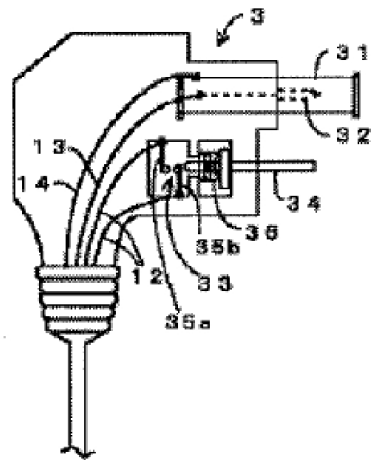

App. 95

Ex. 1009, Figs. 1–2. Figure 1 depicts AC plug 1, AC adapter 2, and DC plug 3, wherein AC adapter 2 converts AC power current from AC plug 1 (which receives power from a commercial power source) to DC current for supplying power to DC plug 3. *Id.* ¶ 9. Figure 1 further depicts circuitry in AC adapter 2, including transformer 21, rectifier 22, and smoothing circuit 23. *Id.* ¶ 10. Figure 2 depicts the interior of DC plug 3. *Id.* ¶ 12. Depicted in the figures, terminals 21a and 21b of the primary winding of transformer 21 are connected to the two terminals of AC plug 1 via wires 11 and 12, wherein wire 12 includes switch 33. *Id.* ¶ 11. When an electronic device is plugged into DC plug 3, pin 34 is depressed and causes electrically conductive tangent points 35a and 35b to contact each other, thereby closing the circuit so that current can be supplied to the primary winding of transformer 21 via wire 12. *Id.* ¶ 14. When no electronic device is plugged into DC plug 3, spring 36 pushes pin 34 outward so that tangent points 35a and 35b do not contact each other, thus opening the circuit so that no power from the commercial power source is supplied to the primary winding of transformer 21. *Id.* ¶ 15. Sakamoto discloses that, in this manner, “the consumption of energy from the commercial power source is completely eliminated and the wasteful consumption of power can be prevented.” *Id.*

2. Overview of Odaohhara (Ex. 1010)

Odaohhara relates to an AC adapter that converts AC power from a commercial power source to DC power, wherein the AC adapter is configured to reduce

App. 96

power loss. Ex. 1010,4:16–26,1:8–11. Odaohhara discloses that power loss is reduced by operating the AC adapter at a first switching frequency when the AC adapter is connected to the jack of the device being charged, and operates at a second switching frequency when the AC adapter is disconnected from the jack. *Id.* 2:42–49. Figure 1 of Odaohhara is reproduced below.

FIG. 1

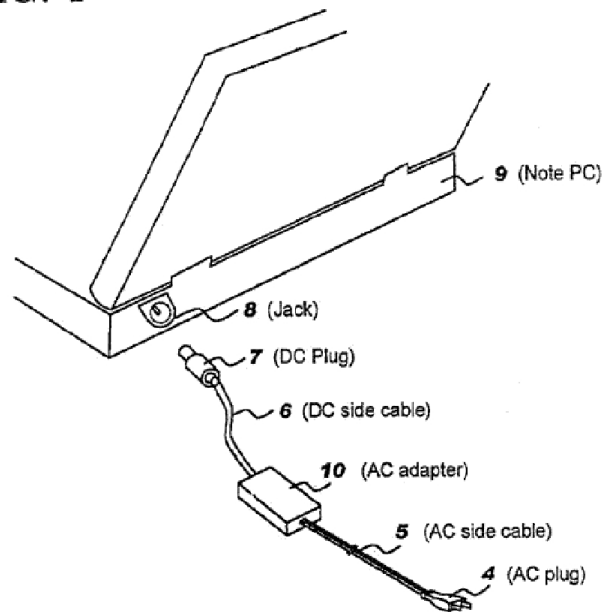

Ex. 1010, Fig. 1. Figure 1 depicts AC plug 4 for receiving commercial AC power, which is supplied through AC cable 5 to AC adaptor 10. *Id.* at 4:19–22. AC adaptor 10 converts the AC power source voltage to DC voltage, and the DC voltage is transmitted through DC side cable 6 to DC plug 7, where the power may be

transmitted through jack 8 to Note PC 9. *Id.* at 4:22–28. Odaohhara discloses including a mechanical switch in DC plug 7 such that when the switch is open, the AC adapter shifts to a low-power-loss mode, i.e., second switching frequency. *Id.* at 5:49–50, 6:10–16, 6:25–31.

3. *Analysis*

Claim 4 depends directly from independent claim 1. Petitioner identifies where each element of claim 1 is disclosed in Sakamoto in its analysis with respect to claim 1. Pet. 16–22,36.

With respect to the preamble of claim 1, Petitioner relies on Sakamoto’s AC adapter 2 and DC barrel connector 3 for disclosure of a “power device for supplying power to a portable rechargeable electronic device.” Pet. 16. Patent Owner does not make any arguments regarding the preamble of claim 1. We are satisfied for purposes of this decision that Sakamoto’s AC adapter 2 and DC barrel connector 3 comprise a power device for supplying power as recited in the preamble.

Petitioner argues Sakamoto’s AC plug 1 satisfies the “first portion for receiving electrical input power” limitation of claim 1 because AC plug 1 connects to a power outlet. *Id.* (citing Ex. 1009 ¶¶ 9, 22). Petitioner argues Sakamoto discloses that the claimed power device (i.e., AC adapter 2) comprises the first portion (i.e., AC plug 1) because Sakamoto discloses that AC plug 1 and AC adapter 2 may be integrated into one body. *Id.* at 16–17 (citing Ex. 1009 ¶ 22). Petitioner argues further that the input power received by AC plug 1 has an

input voltage, as required by claim 1, because Sakamoto discloses the input is an “alternating current,” which inherently has input voltage. *Id.* at 17 (citing Ex. 1009 ¶ 9; Ex. 1019 ¶¶ 58–59).

Petitioner argues Sakamoto’s DC plug 3 satisfies the “second portion for delivering electrical output power” limitation of claim 1 because Sakamoto discloses that DC plug 3 supplies direct current power to an electronic device. Pet. 17.

With respect to the limitation of claim 1 requiring “a connector located on the second portion and removably connectable with the electronic device,” Petitioner relies on cylindrical terminal 31 included in DC plug 3, wherein “terminal (31) inserts into a terminal of a computer to removably connect with the computer.” *Id.* at 18 (citing Ex. 1009 ¶¶ 14, 9; Ex. 1019 ¶ 61).

As to claim 1’s “switch assembly” limitation, Petitioner relies on the combination of Sakamoto’s operation pin 34, spring 36, and tangent points 35a and 35b. Pet. 18–22 (citing Ex. 1009 ¶ 13). Petitioner argues operation pin 34 is a “member movable to and between a first and second position.” *Id.* at 19 (citing Ex. 1009 ¶¶ 13, 14; Ex. 1019 ¶ 64). When pin 34 is in a first position, i.e., depressed, contact points 35a and 35b contact each other, thus closing the circuit so that power is delivered (i.e., the power device is in an “on” state). *Id.* (citing Ex. 1009 ¶ 14). When pin 34 is in a second position, i.e., not depressed, contact points 35a and 35b do not contact each other, thus forming an open circuit

in which power is not drawn (i.e., the power device is in an “off” state). *Id.* (citing Ex. 1009 ¶ 15).

Patent Owner does not raise any arguments as to whether Sakamoto discloses the limitations of claim 1. We are satisfied for the purposes of this Decision that Petitioner has made the necessary showing as to claim 1.

Claim 4 further recites “[t]he power device of claim 1 wherein the switch assembly member is a sheath longitudinally movable to and between the first and second positions.” Petitioner acknowledges Sakamoto does not disclose a sheath, but argues it would have been obvious, in view of Odaohhara, to modify the moveable member in Sakamoto to be a sheath. *Id.* at 36–39. Petitioner argues, in particular, that Sakamoto teaches operational pin 34 can touch another body and become deformed. *Id.* at 38 (citing Ex. 1009 ¶ 20). To address this, Sakamoto discloses an embodiment in which cylindrical housing 92 is included over pin 34, depicted in Figures 10a and 10b, reproduced below.

[FIG. 10]

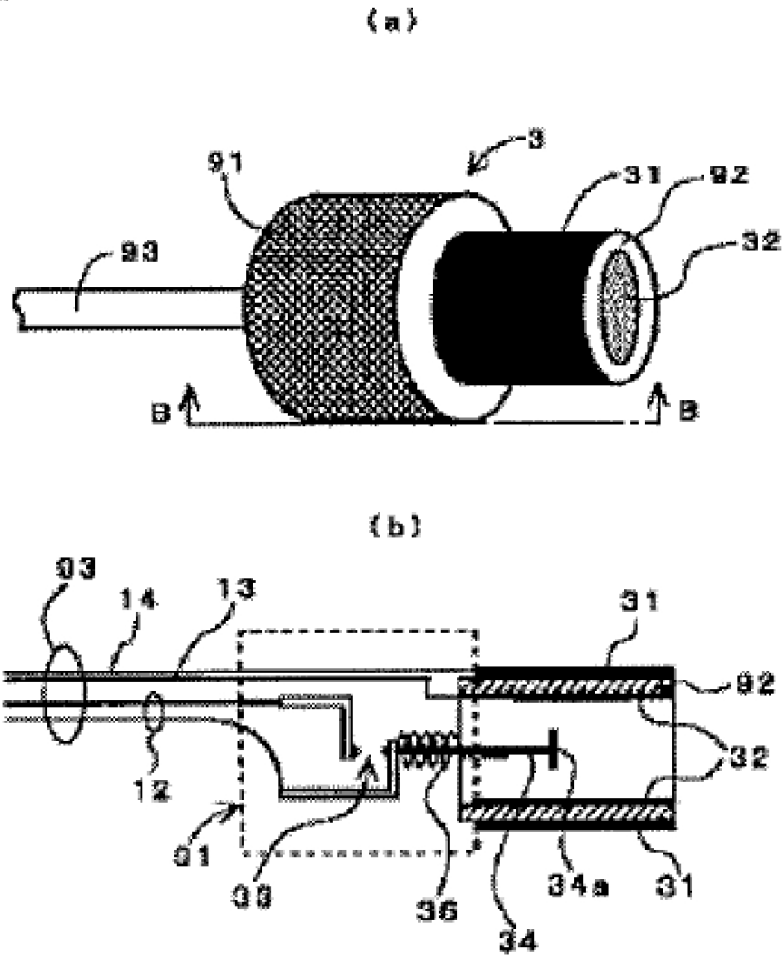

Ex. 1009, Figs. 10a, 10b. Depicted in Figures 10a and 10b, pin 34 still operates as a switch within housing 92, but housing 92 is not moveable. *Id.* ¶ 20. Sakamoto discloses that “since the operation pin 34 exists inside the second cylindrical housing 92, there is no risk of touching another body and deforming,” and that as a

result, “the risk of malfunction is small, and a compact DC plug can be provided.” *Id.*

Odaohhara provides a switch assembly in which a longitudinally moveable sheath, i.e., moveable section 52, acts as a switch to switch a power device between being an open and a closed circuit. Ex. 1010, 5:56–59, 6:3–16, Figs. 3A, 3B. Odaohhara’s switch assembly is depicted in Figures 3a and 3b, reproduced below.

3A

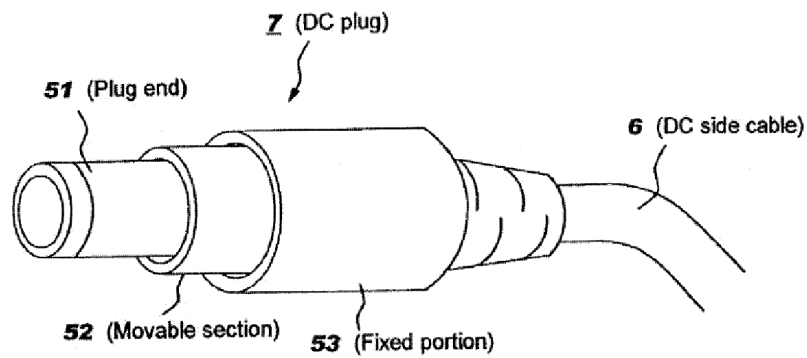

3B

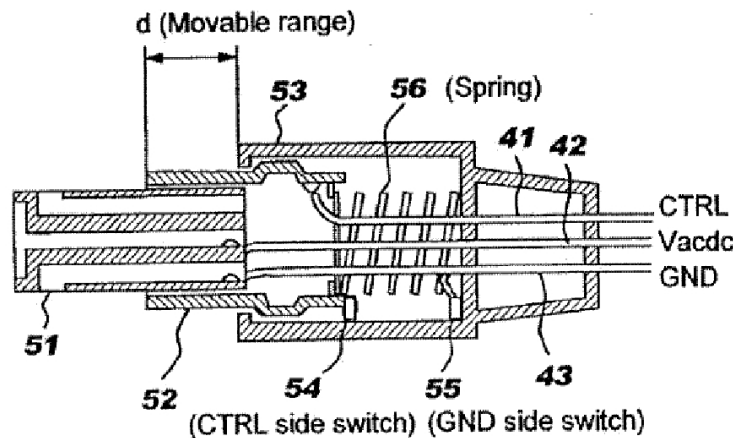

Ex. 1010, Figs. 3a, 3b. Moveable section 52 in Odaohhara operates on the same principle as pin 34 in Sakamoto. A spring is used in Odaohhara to bias moveable section 52 to an extended position (*id.* at 6:3-16), just as a spring is used in Sakamoto to bias pin 34 to an extended position (Ex. 1009 ¶¶ 14-15). In Odaohhara, when an electronic device is connected to jack 8, moveable section 52 contracts a spring, and CTRL slide switch 54 contacts GND side switch 55 to close the circuit. Ex. 1010, 6:3-16. Similarly, when an electronic device is connected to terminal 31 in Sakamoto, pin 34 contracts the spring and brings tangent points 35a and 35b into contact with each other to close the circuit. Ex. 1009 ¶¶ 14-15. Petitioner argues Odaohhara's moveable housing 52 provides a more sturdy structure than Sakamoto's pin 34, and it would therefore have been obvious to a skilled artisan to modify Sakamoto's pin 34 to include a sheath. Pet. 38.

Petitioner also argues that a person of ordinary skill in the art would have recognized that pin 34 in Sakamoto is not symmetrical around the point at which an electronic device is connected to DC plug 3, namely terminal 31. *Id.* According to Petitioner, a skilled artisan would have recognized the benefit of providing the moveable sheath taught in Odaohhara to allow pressing at any position about terminal 31 to close Sakamoto's switch assembly. *Id.* Such a modification, Petitioner argues, would have been a combination of known elements in a predictable way to produce predictable results. *Id.* at 39 (citing *KSR Int'l Co. v. Teleflex, Inc.*, 550 U.S. 398, 417 (2007); *see also* Ex. 1019 ¶¶ 139–140 (testimony of Dr. Horenstein)[)].

Patent Owner asserts Petitioner is re-hashing an argument made previously with a different primary reference, but does not explain why Petitioner's argument is the same as one made previously. In particular, Patent Owner cites to portions of the Petition in which Petitioner argues that the arguments in the Petition are distinguishable from arguments made during reexamination, and Patent Owner does not explain why Petitioner is incorrect. Prelim. Resp. 19 (citing Pet. 9–10). Patent Owner's unsupported assertion is entitled to little weight. Patent Owner also argues pin 34 in Sakamoto closes a circuit involving wire 12, whereas moveable housing 52 in Odaohhara involves a coaxial cable having two wires. *Id.* at 19–20. According to Patent Owner, a coaxial cable cannot simply be substituted for wire 12 in Sakamoto. *Id.* at 20. Petitioner, however, does not argue a simple substitution of one

cable or wire for another. Petitioner argues that it would have been obvious to modify Sakamoto to use a sheath instead of a pin in the switching assembly. We are persuaded for purposes of this Decision that it would have been obvious in view of Odaohhara to modify Sakamoto to include a sheath in the switching assembly to provide a sturdier structure that avoids deformation and is symmetrical around terminal 31.

We have reviewed the parties' arguments and supporting evidence, and we are persuaded, for purposes of this decision, that Petitioner has demonstrated a reasonable likelihood it would prevail in showing unpatentability of claim 4 of the '833 patent as obvious over Sakamoto and Odaohhara.

E. Asserted Obviousness of Claims 11, 12, 17, 18, 20, and 21 over Noguchi, Suzuki, and Huang

Petitioner asserts claims 11, 12, 17, 18, 20, and 21 of the '833 patent are unpatentable as obvious over Noguchi, Suzuki, and Huang. Pet. 39–60. Patent Owner disputes Petitioner's assertions of unpatentability over these prior art references. Prelim. Resp. 15–18. For reasons that follow, we institute *inter partes* review of claims 11, 12, 17, 18, 20, and 21 as obvious over Noguchi, Suzuki, and Huang.

1. Overview of Noguchi (Ex. 1011)

Noguchi relates to a battery charger including converter 20 for converting AC current supplied by an

AC power source to DC current for charging a battery, wherein the battery charger “automatically prevents unnecessary standby power consumption caused by a converter built in to the charger.” Ex. 1011, Abstract. Noguchi discloses preventing such power consumption by providing switch 10 on the input side of converter 20 that turns the converter off when the battery is removed from the battery charger. *Id.* Figure 1 of Noguchi, reproduced below, depicts the circuitry of the battery charger.

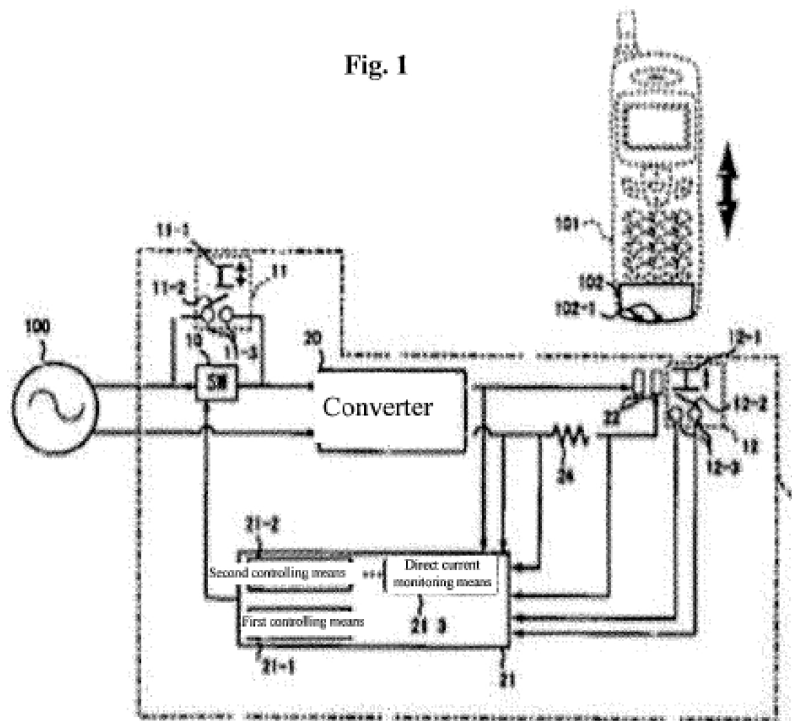

Ex. 1011, Fig. 1. Depicted in Figure 1, AC power supply 100 supplies AC current to converter 20, which converts the AC current into DC current. *Id.* ¶ 13. The DC current, i.e., DC power, is supplied to rechargeable battery 102. *Id.* Switch 10 is interposed between AC power supply 100 and the input side of converter 20, and when open (i.e., off), cuts off the alternating current from AC power supply 100. *Id.* at 16. Control unit 21, depicted in Figure 1, opens switch 10 when either rechargeable battery 102 is detached from the charger or when battery 102 is fully charged. *Id.* ¶ 26. Noguchi further discloses bypass switch 11, which is closed, i.e., turned on, when bypass switch button 11-1 is pressed. *Id.* ¶ 34. Bypass switch 11, when closed, bypasses switch 10 and causes AC power to be delivered to converter 20, and therefore rechargeable battery 102, as well as control unit 21, when switch 10 is open. *Id.* ¶¶ 34–35.

2. Analysis

a. Claim 11

Petitioner asserts Noguchi teaches the limitations of claim 11 except for the “connector located on the second portion and removably connectable with the electronic device” limitation, which Petitioner argues is taught by Huang. Pet. 39–51. Petitioner also argues that if we determine the claimed “switch assembly” must include a hard switch, it would have been obvious to modify the switch in Noguchi to be an

electromagnetic switching element such as the latching relay taught in Suzuki. *Id.* at 51–54.

With respect to the preamble, Petitioner relies on Noguchi’s charger 1 as teaching a power device because charger 1 charges mobile electronic devices such as cellular telephone 101, which includes rechargeable battery 102. Pet. 39 (citing Ex. 1011 ¶¶ 2, 11, 12, 15; Ex. 1019 ¶ 159). Patent Owner does not raise arguments regarding the preamble of claim 11. We are persuaded for purposes of this Decision that Noguchi teaches this recitation.

With respect to the limitation directed to “a first portion,” Petitioner relies on plug 30 in Noguchi, which receives electrical input power having an input voltage from a source, i.e., plug 30 receives alternating voltage from AC power supply 100. Pet. 39–40 (citing Ex. 1011 ¶ 12, Figs. 2, 3; Ex. 1019 ¶ 160). Patent Owner does not raise arguments regarding the “first portion” limitation. We are persuaded for purposes of this Decision that Noguchi teaches this limitation.

With respect to the limitation directed to “a second portion,” Petitioner relies on main body case 1-1 in Noguchi, which delivers electrical output power having an output voltage to an electronic device, i.e., case 1-1 delivers direct voltage to rechargeable battery 102 in cellular phone 101. Pet. 40 (citing Ex. 1011 ¶¶ 12, 13; Ex. 1019 ¶ 161). Patent Owner does not raise arguments regarding the “second portion” limitation. We are persuaded for purposes of this Decision that Noguchi teaches this limitation.

With respect to claim 11's requirement that the power device include "circuitry for converting the input power voltage to the output power voltage," Petitioner argues Noguchi's converter 20 satisfies this requirement because it is "a common AC/DC converter." Pet. 40 (citing Ex. 1011 ¶ 14). As to claim 11's further requirement of "circuitry . . . for determining an 'off' state of the circuitry," Petitioner argues control unit 21 of Noguchi determines when the state of switch 10 should be turned to "off." *Id.* at 4041. In particular, Petitioner relies on Noguchi's disclosure that control unit 21 determines whether a condition for turning off switch 10 is present, namely whether "rechargeable battery 102 (cellular telephone 101) is detached from the charger 1 (first condition)" and whether "rechargeable battery 102 has reached a fully charged state (second condition)." *Id.* (citing Ex. 1011 ¶ 26; Ex. 1019 ¶¶ 162–163). Patent Owner does not raise arguments regarding this limitation. We are persuaded for purposes of this Decision that Noguchi teaches this limitation.

Petitioner acknowledges Noguchi does not teach "a connector located on the second portion and removably connectable with the electronic device," as recited in claim 11. Pet. 42. Noguchi instead discloses charging contact points 22 that contact points on rechargeable battery 102. *Id.* at 41 (citing Ex. 1011 ¶ 15; Ex. 1019 ¶ 164). Petitioner argues, however, that it was well known among skilled artisans at the time to include a connector in a cell phone base charger instead of contacts [sic] points as described in Noguchi. *Id.* at 42

(citing Ex. 1019 ¶ 166). Petitioner relies on Huang for this teaching. *Id.* Figure 3 of Noguchi, reproduced below, depicts a cell phone charging base having contact points. Figure 1 of Huang, also reproduced below, depicts a cell phone charging base having connector 13.

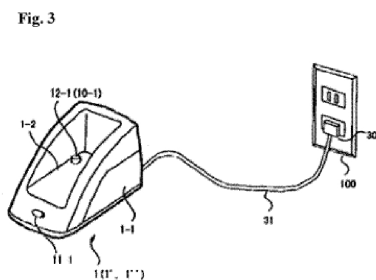

Noguchi Fig. 3 (Ex. 1011)

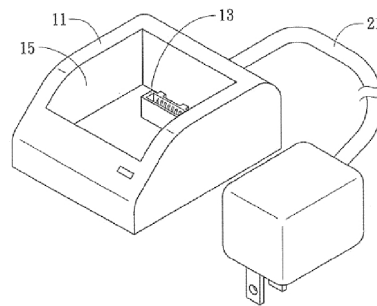

Huang Fig. 1 (Ex. 1013)

Petitioner argues a person of ordinary skill in the art would have been motivated to use a connector, as taught in Huang, in Noguchi's base cell phone charger to provide a more stable structural connection with a cell phone to prevent the phone from falling or otherwise moving while charging. Pet. 43–44 (citing Ex. 1019 ¶¶ 169–170). Petitioner further argues that it would have been obvious for the base to be a male connector port, as taught in Huang, to be compatible with female power ports in cell phones. *Id.* (citing Ex. 1019 ¶¶ 171–173). According to Petitioner, modifying Noguchi to include the connector taught in Huang would have been nothing more than the combination of known elements in a predictable way to produce predictable results. *Id.* at 44 (citing *KSR*, 550 U.S. at 417).

Patent Owner does not raise arguments regarding this limitation. We are persuaded for purposes of this Decision that Petitioner has made a sufficient showing with respect to this limitation.

With respect to the “switch assembly” limitation, Petitioner argues Noguchi discloses two switch assemblies, namely bypass switch 11 and secondary battery detection switch 12. *Id.* at 45. Switch 11 includes bypass switch button 11-1, by-pass switch segment 11-2, by-pass switch terminal/contact point 11-3, and “return spring and the like.” *Id.* (citing Ex. 1011 ¶¶ 18, 20, Fig. 1; Ex. 1019 ¶ 175). Secondary battery detection switch 12 includes secondary battery detection switch button 12-1, secondary battery detection switch segment 12-2, and secondary battery detection switch terminal/contact point 12-3. *Id.* (citing Ex. 1011 ¶ 20, Fig. 1; Ex. 1019 ¶ 176). Petitioner argues both switch 11 and secondary battery detection switch 12 have powered terminals and are responsive to movement or a moveable portion thereof to electrically connect the terminals and provide an output signal to activate the circuitry to an “on” state. *Id.* at 45–51. Patent Owner does not raise arguments regarding this limitation. For purposes of this Decision, we adopt Petitioner’s arguments regarding this limitation, and are persuaded Noguchi teaches this limitation.

The parties dispute whether Noguchi, or the combination of Noguchi and Suzuki, teaches or suggests the limitation “wherein the circuitry automatically turns the circuitry to the ‘off’ state, the circuitry drawing no power when in the ‘off’ state.” Petitioner argues

Noguchi discloses the claimed circuitry, namely the combination of switch 10, converter 20, and control unit 21. Petitioner relies on Noguchi's disclosure that when control unit 21 detects battery 102 is detached from charger 1 or is fully charged, switch 10 automatically turns off. Pet. 51 (citing Ex. 1011 ¶¶ 26–29). According to Petitioner, the circuitry draws no power when in the “off” state because Noguchi discloses that “when the switch 10 is turned off, the alternating current for the converter 20 is cut off.” *Id.* (citing Ex. 1011 ¶ 33).

Patent Owner points to the Board's determination during reexamination of the '833 patent regarding interpretation of the phrase “drawing no power when in the ‘off’ state.” Prelim. Resp. 16 (citing Ex. 1004, 26). In particular, the Board noted that the '833 patent specification discloses that when power is cut, “the power draw is zero or negligible (i.e., measured in microwatts).” Ex. 1004, 26 (citing Ex. 1001 6:49–50). The Board determined that in order for the prior art at issue to satisfy the claim limitation, it had to disclose drawing power in the “off” state that “is only on the order of microwatts.” *Id.* (citing *Edward Lifesciences LLC v. Cook Inc.*, 582 F.3d 1322, 1334 (Fed. Cir. 2009) (noting that the term “i.e.” in a patent specification signals an intent to define the term to which it refers)). Patent Owner does not, however, provide persuasive argument or evidence that Noguchi draws more than zero or negligible (on the order of microwatts) power when switch 10 is open, i.e., “off.”

The '833 patent explains that “[i]n order to be a true ‘zero-energy’ device, the power input (i.e., AC input) to the power device must be cut,” and that “the point in the power device circuitry where the circuit is broke is important.” Ex. 1001, 2:53–66. The '833 patent explains that the portion of a power device most directly responsible for power draw or phantom load in the “off” state are the switcher IC chip, transformer, and components downstream therefrom because they continue to draw power from the AC input power source even when the electronic device is disconnected from the power device. *Id.* at 8:20–23. According to the '833 patent, phantom load in the “off” state is virtually eliminated, therefore, by placing the switch that opens the circuit (such as at terminals 50a and 50b depicted in Figure 8) upstream from the transformer. *Id.* at 8:23–31. Like the '833 patent, Noguchi discloses placing switch 10 upstream from converter circuitry, so that when the switch is open, the AC current supplied by AC power supply 100 is cut off. Ex. 1011 ¶ 16; *see also id.* at Fig. 1 (depicting switch 10 interposed between AC power supply 100 and converter 20). Accordingly, we are persuaded for purposes of this Decision that Petitioner has satisfied its burden with respect to this claim limitation.

Petitioner argues that, should we determine a “hard switch” is required for the circuitry to be in an “off” state, it would have been obvious to modify switch 10 in Noguchi to comprise a latching relay. Pet. 51–52. We are persuaded for purposes of this Decision that the circuitry need not be a “hard switch” because the '833

patent specification discloses that the “off” state may be caused by a “solid state equivalent such as a MOSFET switch.” Pet. 52 (*citing* Ex. 1001, 9:8–11); *see also* Ex. 1001, claim 19 (reciting that “the circuitry includes a solid state switch element that opens . . . to change the circuitry to the ‘off’ state”). Nevertheless, we are persuaded that this limitation is also taught by Suzuki’s disclosure of phototriac (2), electromagnetic relay (4), and latching relay, and that a person of ordinary skill in the art would have combined Noguchi and Suzuki for the reasons argued by Petitioner. Pet. 52–54 (*citing* Ex. 1012, 20:15–20, 4:35–40, Fig. 2; 3:27–35, 4:14–27).

We have reviewed the parties’ arguments and supporting evidence, and we are persuaded, for purposes of this proceeding, that Petitioner has demonstrated a reasonable likelihood it would prevail in showing that claim 11 of the ’833 patent is unpatentable as obvious over Noguchi and Huang, and as obvious over Noguchi, Huang, and Suzuki.

b. Claims 12, 17, 18, 20, and 21

Petitioner provides evidence and arguments that the combination of Noguchi, Suzuki, and Huang teaches or suggests each of the limitations of claims 12, 17, 18, 20, and 21, which all depend from claim 11. Pet. 54–60. Patent Owner does not raise additional arguments to dispute Petitioner’s assertions other than those it raises with respect to claim 11. Prelim. Resp. 15–18. We have reviewed the parties’ arguments and

supporting evidence, and we are persuaded, for purposes of this proceeding, that Petitioner has demonstrated a reasonable likelihood it would prevail in showing that claims 12, 17, 18, 20, and 21 are unpatentable as obvious over Noguchi and Huang, and as obvious over Nguchi, Huang, and Suzuki.

F. Asserted Obviousness of Claim 16 over Noguchi, Suzuki, Huang, and Byun

Claim 16 further recites the power device of claim 11, “wherein the circuitry includes a timer programmed with a predetermined time period, the timer providing a timer signal to the circuitry at the conclusion of the timer period, and the circuitry automatically changes to the ‘off’ state in response to the timer signal.” The ’833 patent provides an example of this feature, disclosing a timer so that a slight temporal pause in power will not cause switch 210 to open, thereby shutting off power. Ex. 1001, 9:29–38, 9:7–10. Petitioner acknowledges Noguchi does not disclose this feature. Pet. 61. In Noguchi, control unit 21 automatically changes to the “off” state (i.e., turns switch 10 off) in response to removing the cell phone from the charging base, rather than in response to a timer. Pet. 60 (citing Ex. 1011 ¶ 27). Petitioner argues that Byun, however, teaches using a timer so that the device is not turned “off” automatically when a user switches the device to standby mode, but rather switches to “off” only after a certain amount of time has lapsed after switching to standby mode. *Id.* at 61 (citing Ex. 1014,

7¹⁰). According to Petitioner, it would have been obvious to incorporate Byun’s timer and timer signal into Noguchi’s control unit 21 to allow for delay before turning switch 10 off in response to removing a cell phone from the charging base. *Id.* Petitioner argues this would prevent unnecessarily shutting “off” power if the cell phone is inadvertently removed from or knocked out of the charging base and placed back in the base within a predetermined time period. *Id.* at 61–62 (citing Ex. 1019 ¶¶ 246–252). Patent Owner does not raise arguments other than those made with respect to claim 11.

We have reviewed the parties’ arguments and supporting evidence, and we are persuaded, for purposes of this proceeding, that Petitioner has demonstrated a reasonable likelihood it would prevail in showing unpatentability of claim 16 of the ’833 patent as obvious over Noguchi, Huang, and Byun, and as obvious over Noguchi, Huang, Suzuki, and Byun.

G. Asserted Obviousness of Claim 22 over Noguchi, Suzuki, Sakamoto, and Odaohhara

Claim 22 recites the power device of claim 11 “wherein the switch assembly comprises a sheath longitudinally movable to and between first and second positions, wherein the first position corresponds to the ‘on’ state.” With respect to charging a cell phone, Noguchi describes charging case 1-1 having a user

¹⁰ Petitioner cites to the Bates. No. of Exhibit 1014, rather than to the original document’s page number. To avoid confusion, we adopt Petitioner’s citation convention.

activated push button switch 12 adjacent to charging points 22, which charges battery 102 when battery 102 comes into contact with charging points 22. Pet. 62–63 (citing Ex. 1011 ¶¶ 15, 18, 20, 22). Noguchi teaches, however, that “the present invention is not limited to a charger for a cellular telephone,” and contemplates charging a battery for laptop computers. *Id.* at 64 (citing Ex. 1011 ¶¶ 2, 69). Petitioner argues a person of ordinary skill in the art would have recognized a laptop computer would not have fit in charging case 1-1, and therefore would have been motivated to modify the charger in Noguchi to allow for powering a laptop when a laptop is connected to the charger. *Id.* Sakamoto teaches using a charging pedestal to charge a cell phone, similar to Noguchi’s case 1-1, to charge a cell phone. *Id.* (citing Ex. 1009 ¶ 24, Figs. 4–6). Sakamoto also teaches using a cord with a plug, having a switch assembly at the end of DC plug 3, for charging a laptop computer. *Id.* at 65–66 (citing Ex. 1009 ¶ 27, Figs. 1, 6). According to Petitioner, a skilled artisan would have been motivated, therefore, to modify Noguchi to use a cord with a switch assembly at the end that connects with a DC powered device such as a laptop computer. *Id.* at 67. Petitioner argues further that a skilled artisan would have been motivated to include the claimed “connector” that is “removably connectable with the electronic device,” in the form of Sakamoto’s terminal 31. *Id.* at 68. We find Petitioner’s arguments persuasive because Noguchi contemplates charging a laptop computer, and Sakamoto teaches the use of terminal 31 and a cord, rather than a pedestal, to charge

a laptop computer, as well as the desirability of placing the switching mechanism at the end of the cord.

Petitioner argues further that it would have been obvious in view of Odaohhara to modify pin 34 of Sakamoto to comprise a sheath, for the same reasons Petitioner argues with respect to claim 4. Pet. 68–69. For the reasons we discussed with respect to claim 4, we are persuaded by Petitioner’s arguments.

Patent Owner does not raise arguments other than those made with respect to claim 11.

We have reviewed the parties’ arguments and supporting evidence, and we are persuaded, for purposes of this proceeding, that Petitioner has demonstrated a reasonable likelihood it would prevail in showing the unpatentability of claim 22 of the ’833 patent as obvious over Noguchi, Sakamoto, and Odaohhara, and as obvious over Noguchi, Suzuki, Sakamoto, and Odaohhara.

H. Asserted Obviousness of Claims 11, 12, 17, 18, 20, and 21 over Eishi and Luu

Petitioner asserts claims 11, 12, 17, 18, 20, and 21 of the ’833 patent are unpatentable as obvious over Eishi and Luu. Pet. 69–82. Patent Owner disputes Petitioner’s assertions of unpatentability over these prior art references. Prelim. Resp. 18.

We do not find Petitioner’s arguments with respect to this ground to be as persuasive as its arguments regarding obviousness over Noguchi and Huang,

particularly Petitioner's lack of detailed explanation regarding how Luu's AC converter would be incorporated in Eishi in order to ensure zero or negligible power draw in an "off" state. Because we institute an *inter partes* review of claims 11, 12, 17, 18, 20, and 21 based on other grounds, we exercise our discretion not to institute based on the combination of Eishi and Luu.

III. CONCLUSION

On this record, we are persuaded there is a reasonable likelihood that Petitioner would prevail in showing: claim 4 is unpatentable as obvious over Sakamoto and Odaohhara; claims 11, 12, 17, 18, 20, and 21 are unpatentable as obvious over Noguchi and Huang, and as obvious over Noguchi, Huang, and Suzuki; claim 16 is unpatentable as obvious over Noguchi, Huang, and Byun, and as obvious over Noguchi, Huang, Suzuki, and Byun; claim 22 is unpatentable as obvious over Noguchi, Sakamoto, and Odaohhara, and as obvious over Noguchi, Suzuki, Sakamoto, and Odaohhara. The Board has not made a final determination concerning the patentability of any of the challenged claims.

IV. ORDER

Accordingly, it is:

ORDERED that pursuant to 35 U.S.C. § 314, an *inter partes* review is hereby instituted as to claims 4,

11, 12, 16–18, and 20–22 of the '833 patent on the following grounds of unpatentability:

A. Claim 4 under 35 U.S.C. § 103(a) as obvious over the combination of Sakamoto and Odaohhara;

B. Claims 11, 12, 17, 18, 20, and 21 under 35 U.S.C. § 103(a) as obvious over the combination of Noguchi and Huang, and as obvious over the combination of Noguchi, Huang, and Suzuki;

C. Claim 16 under 35 U.S.C. § 103(a) as obvious over the combination of Noguchi, Huang, and Byun, and as obvious over the combination of Noguchi, Huang, Suzuki, and Byun; and

D. Claim 22 under 35 U.S.C. § 103(a) as obvious over the combination of Noguchi, Sakamoto, and Odaohhara, and as obvious over the combination of Noguchi, Suzuki, Sakamoto, and Odaohhara; and

FURTHER ORDERED that pursuant to 35 U.S.C. § 314(a), *inter partes* review of the '833 patent is hereby instituted commencing on the date of entry of this Order, and, pursuant to 35 U.S.C. § 314(c) and 37 C.F.R. § 42.4, notice is hereby given of the institution of trial.

PETITIONER:

Ketan Vakil
kvakil@swlaw.com

Andrew Flior
aflior@swlaw.com

App. 120

PATENT OWNER:

Jerold Schneider
Jerold.schneide@sriplaw.com

Kevin Cudlipp
Kevin.cudlipp@sriplaw.com
